

A Review on UPQC for Power Quality Improvement in Distribution System

B.GOPAL

Received: 10 December 2012 Accepted: 31 December 2012 Published: 15 January 2013

Abstract

In recent years, Power engineers are increasingly concerned over the quality of the electrical power. In modern power system consists of wide range of electrical, electronic and power electronic equipment in commercial and industrial applications. Since most of the electronic equipments are nonlinear in nature these will induce harmonics in the system, which affect the sensitive loads to be fed from the system. One among the many compensating devices is Unified Power Quality Conditioner (UPQC) which specifically aims at the integration of series-active and shunt-active power filters to mitigate any type of voltage and current fluctuations and power factor correction in a power distribution network, such that improved power quality can be made available at the point of common coupling. In This paper presents a comprehensive review on the unified power quality conditioner (UPQC) to enhance the electric power quality at distribution levels. This is intended to present a broad overview on the different possible UPQC system configurations

Index terms— power quality (pq), harmonics, voltage sag, voltage swell, active power filter (apf), unified power quality conditioner (upqc),

1 Introduction

he quality of the power is effected by many factors like harmonic contamination, due to the increment of non-linear loads, such as large thyristor power converters, rectifiers, voltage and current flickering due to arc in arc furnaces, sag and swell due to the switching (on and off) of the loads etc. These problems are partially solved with the help of LC passive filters. However, this kind of filter cannot solve random variations in the load current waveform and voltage waveform. Active filters can resolve this problem, however the cost of active filters is high, and they are difficult to implement in large scale. Additionally, they also present lower efficiency than shunt passive filters [1].

This paper focuses on a unified power quality condition (UPQC). The UPQC is one of the APF family members where shunt and series APF functionalities are integrated together to achieve superior control over several power quality problems simultaneously. It is noticed that more than half of the papers on UPQC have been reported in the last five years, which indeed suggest the rapid interest in utilizing UPQC to improve the quality of power at the distribution level [2], [3].

The UPQC is a combination of series and shunt active filters connected through a common DC link capacitor. The main purpose of a UPQC is to compensate for supply voltage power quality issues such as, sags, swells, unbalance, flicker, harmonics, and for load current power quality problems such as, harmonics, unbalance, reactive current and neutral current [4].

2 II.

3 Power Quality Problems

Power quality is very important term that embraces all aspects associated with amplitude, phase and frequency of the voltage and current waveform existing in a power circuit. Any problem manifested in voltage, current or frequency deviation that results in failure of the customer equipment is known as power quality problem.

The increasing number of power electronics based equipment has produced a significant impact on the quality of electric power supply. The lack of quality power can cause loss of production, damage of equipment or appliances, increased power losses, interference with communication lines and so forth. Therefore, it is obvious to maintain high standards of power quality [3].

The major types of power quality problems are: Interruption, Voltage-sag, Voltage-swell, Distortion, and Harmonics. Harmonics are sinusoidal voltages or current having frequency that are integer multiples of the fundamental frequency. Here, 3rd harmonics is seen in the Fig. 6.

4 a) Interruption

In order to meet PQ standard limits, it may be necessary to include some sort of compensation. Modern solutions can be found in the form of active rectification or active filtering. A shunt active power filter is suitable for the suppression of negative load influence on the supply network, but if there are supply voltage imperfections, a series active power filter may be needed to provide full compensation

5 III. Basic Configuration of upqc

In recent years, solutions based on flexible ac transmission systems (FACTS) have appeared. The application of FACTS concepts in distribution systems has resulted in a new generation of compensating devices. A unified power-quality conditioner (UPQC) is the extension of the unified power-flow controller (UPFC) concept at the distribution level. It consists of combined series and shunt converters for simultaneous compensation of voltage and current imperfections in a supply feeder. However, a UPFC only needs to provide balance shunt and/or series compensation, since a power transmission system generally operates under a balanced and distortion free environment. On the other hand, a power distribution system may contain dc components, distortion, and unbalance both in voltages and currents. Therefore, a UPQC should operate under this environment while performing shunt and/or series compensation [5]. The main purpose of a UPQC is to compensate for supply voltage power quality issues, such as, sags, swells, unbalance, flicker, harmonics, and for load current power quality problems, such as, harmonics, unbalance, reactive current, and neutral current. Fig. 1 shows a single-line representation of the UPQC system configuration. The key components of this system are as follows.

1. Two inverters one connected across the load which acts as a shunt APF and other connected in series with the line as that of series APF.

2. Shunt coupling inductor L_{Sh} is used to Interface the shunt inverter to the network. It also helps in smoothing the current wave shape. Sometimes an isolation transformer is utilized to electrically isolate the inverter from the network.

6 A common dc link that can be formed by using a

Capacitor or an inductor. In Fig. 1, the dc link is realized using a capacitor which interconnects the two inverters and also maintains a constant self supporting dc bus voltage across it.

4. An LC filter that serves as a passive low-pass filter (LPF) and helps to eliminate high-frequency switching ripples on generated inverter output voltage. 5. Series injection transformer that is used to connect the series inverter in the network. A suitable turn ratio is often considered to reduce the current or and voltage rating of the series inverter.

The integrated controller of the series and shunt APF of the UPQC to provide the compensating voltage reference V_C^* and compensating current reference I_C^* to be synthesized by PWM converters [6], [7].

The shunt active power filter of the UPQC can compensate all undesirable current components, including harmonics, imbalances due to negative and zero sequence components at the fundamental frequency. In order to cancel the harmonics generated by a nonlinear load, the shunt inverter should inject a current as governed by the following equation: $I_C(t) = I_L^*(t) - I_S(t)$ (1)

Where $I_C(t)$, $I_L^*(t)$, and $I_S(t)$ represent the shunt inverter current, reference load current, and actual source current, respectively.

The series active power filter of the UPQC can compensate the supply voltage related problems by injecting voltage in series with line to achieve distortion free voltage at the load terminal. The series inverter of the UPQC can be represented by following equation: $V_C(t) = V_L^*(t) - V_S(t)$ (2)

Where $V_C(t)$, $V_L^*(t)$, and $V_S(t)$ represent the series inverter voltage, reference load voltage, and actual source voltage, respectively [8] [9].

7 IV. Classification of upqc

The Unified Power Quality Conditioner are classified on various bases like converter used, topology, supply type and compensation method. The UPQC is classified in two main groups which is based on, Physical structure and Voltage sag compensation [4].

8 a) Physical Structure

The key parameters that attribute to these classifications are: Type of energy storage device used, Number of phases, and Physical location of shunt and series inverter. The voltage sag on a system is considered as one of the important power quality problems. There are mainly four methods to compensate the voltage sag in UPQC-based applications. To mitigate power quality problems in the distribution system and UPQC's different configurations are classified based on the type of supply system. There are mainly two types of supply a) singlephase and b) three-phase.

Single-phase two-wire two-Hbridge UPQC configuration is as shown in Fig. 9. Another two topologies first is 3-leg topology (total 6 switches). Apart from total 6 switches, 4 switches are used in series inverter and 2 switches are used in shunt inverter. Second half-bridge topology, 2 switches are used in series inverter and 2 switches used in shunt inverter [10]. For neutral current compensation in three-phase four-wire (3P4W) system, various shunt inverter configurations are given, namely, four-leg (4L), two split-capacitor (2C) and three-H bridge (3HB) [13] [15].

The 3HB topology use three single-phase Hbridge inverter connected to same dc bus of the UPQC. The 2C topology use two split-capacitor on dc side and the midpoint of two capacitor is at zero potential which is used as connection point for the fourth wire. Among all three topologies four-leg (4L) is give better control over neutral current due to four-leg. In this paper three-phase four-wire based on four-leg (4L) shunt inverter topology [24], is shown in Fig. 11. 1. Three-phase UPQC is possible in three-phase three-wire or three-phase four-wire (3P3W or 3P4W) 2. Single-phase UPQC is further classified on:

- (i) Two H-bridge (ii) 3-Leg topology (iii) Half Bridge

9 2.

Three-phase four-wire UPQC is further classified on:

- (i) Four-Leg (ii) Split Capacitor (iii) Three-H Bridge 3. In single-phase system load reactive current, current harmonics are major problems 3.-In three-phase three wire system apart from reactive current, current harmonics additional problem is current Unbalance. In three phase four-wire system additional neutral current problem 4. Voltage related power quality problems are similar for both single and three phase system except voltage unbalance compensation is not required in single-phase system 4. Voltage related power quality problems are similar for both single and three phase system except voltage unbalance compensation is required in three-phase system There are various types of configurations of UPQC is given in above classification. Fig. 7 to 11 all are represents right shunt UPQC (UPQC-R) and when in Fig. 7 to 11 shunt inverter is located in left at that time it is called left shunt UPQC (UPQC-L). Among this two configurations UPQC-R is commonly used because current flow through series transformer is mostly sinusoidal. The UPQC-L is rarely used due to interference between shunt inverter and passive filters.

First, the comparison between Interline UPQC (UPQC-I) and Multi-converter UPQC (UPQC-MC) [23] is given in TABLE-3. Second, the comparison between Modular UPQC (UPQC-MD) and Multi-level UPQC (UPQC-ML) [20], [26], [27] is given in TABLE-4. 2. The H-bridge modules for shunt inverter is connected in series through multi-winding transformer, while, series inverter is connected in series with using series transformer.

2. In UPQC-ML three-level topology require double semiconductor switches.

3. UPQC-MD can be useful to achieve higher power levels.

3. UPQC-ML can also be useful to achieve higher power levels.

Third, the comparison between Distributed UPQC (UPQC-D) and Distributed Generator Integrated UPQC (UPQC-DG) [14] [16] [19] [21], is given in TABLE-5.

10 Table 5 : Comparison between UPQC-D & UPQC-DG Distributed UPQC (UPQC-D)

Distributed Generator Integrated UPQC (UPQC-DG) 1. UPQC-D topology is also known as 3P3W to 3P4W Distributed UPQC because 3P-4W system is realized by using 3P3W system.

11 1.

The UPQC can be integrated with one or several DG systems which are nown as UPQC-DG.

2. In UPQC-D system the neutral of series transformer is used as neutral of 3P4W system.

2. The output of DG system is connected to dc bus of UPQC to compensate voltage and current related problems. 3. Fourth leg is added to 3P 4W UPQC to compensate neutral current flowing towards transformer neutral point.

150 3. In UPQC-DG battery can be added at dc bus which is used as stored power and used as backup which give
151 benefit for removing voltage interruption.

152 Finally, the classification is based on voltage sag compensation is given in this section. There are mainly four
153 methods to compensate voltage sag in UPQC based applications, The comparison between Active Power Control
154 (UPQC-P) and Reactive Power Control (UPQC-Q) is given in ? The instantaneous active and reactive power or
155 pq theory, and ? Synchronous reference frame method or d-q theory.

156 In p-q theory instantaneous active and reactive powers are computed, while, the d-q theory deals with the
157 current independent of the supply voltage. Both methods transforms voltages and currents from abc frame to
158 stationary reference frame (p-q theory) or synchronously rotating frame (d-q theory) to separate the fundamental
159 and harmonic quantities.

160 In third stage the gating signals for semiconductor switches of UPQC based on derive compensating commands
161 in terms of voltage or current. Then, these compensating commands are given to PWM, hysteresis or fuzzy logic
162 based control techniques [28].

163 VI.

164 12 Technical and Economical Consideration

165 Technical literature on the APFs can be found since early 1970s [1]. However, the use of UPQC to enhance electric
166 power system quality is reported since mid 1990s [3]. Among the various power quality enhancement devices,
167 STATCOM and few others are commercially available [2]. The technology to develop commercial UPQC system
168 is available today; however, the overall cost and complexity of such a system still imposes some limitations. A
169 250-kVA prototype developed at C-DAC, Thiruvananthapuram, India [17], is the most viable reported prototype.

170 The capacity of small and large-scale renewable energy systems based on wind energy, solar energy, etc.,
171 installed at distribution as well as transmission levels is increasing significantly. These newly emerging DG systems
172 are imposing new challenges to electrical power industry to accommodate them without violating standard
173 requirements (such as, IEEE 1547, IEEE 519). In terms of power quality, the excessive feeder voltage rise due
174 to reverse power flow from DG system and power system stability is of significant importance. Moreover, most
175 of the DG systems utilize power electronic converters as interfacing device to deliver the generated power to
176 the grid. The switching operation of these systems is contributing as increased harmonic levels both in the grid
177 voltages and currents.

178 In this paper, several UPQC configurations and topologies have been discussed. Among these configurations,
179 UPQC-DG could be the most interesting topology for a renewable energy based power system. This configuration
180 can offer multifunctional options, namely, active power delivery from DG system to grid (normal DG operation),
181 voltage and current related power quality compensation (UPQC operation), and uninterruptible power supply
182 operation. Commercial products have started to appear in the market to increase the renewable energy system
183 connectivity by compensating some of these problems. As the penetration levels of DG system on the existing
184 power system continue to increase, the utilization of active compensating technologies (such as, flexible ac
185 transmission system devices and APFs) is expected to increase gradually.

186 13 VII.

187 14 Conclusion

188 The power quality problems in distribution systems are not new but customer awareness of these problems
189 increased recently. It is very difficult to maintain electric power quality at acceptable limits. One modern and
190 very promising solution that deals with both load current and supply voltage imperfections is the Unified Power
191 Quality Conditioner (UPQC). This paper presented a review on the UPQC as a tool to enhance the electric
192 power quality at distribution level. The UPQC is able to compensate supply voltage power quality issues such
193 as, sags, swells, unbalance, flicker, harmonics, and for load current power quality problems such as, harmonics,
194 unbalance, reactive current and neutral current. Among all these configurations, UPQC-DG and UPQC-ML are
195 the most vital topologies to achieve better reliability and power quality at higher power rating of the system.
196 Therefore with the help of these topologies can meet required load demand in future, increase the production in
197 industries and increase the economy of the country.

¹© 2013 Global Journals Inc. (US) © 2013 Global Journals Inc. (US)

²© 2013 Global Journals Inc. (US)

³Global Journal of Researches in Engineering

⁴, , © 2013 Global Journals Inc. (US)



1

Figure 1: Figure 1 :

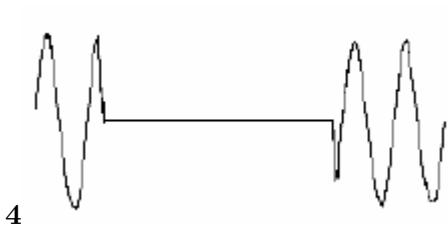

4

Figure 2: Figure 4 :

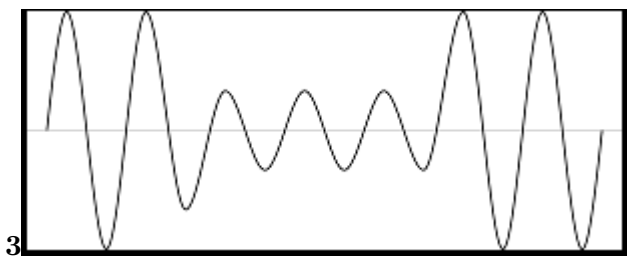

3

Figure 3: Figure 3 :

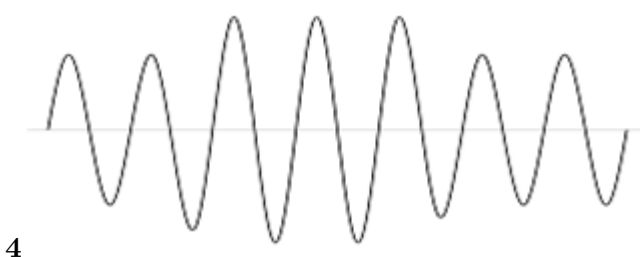

4

Figure 4: Figure 4 :

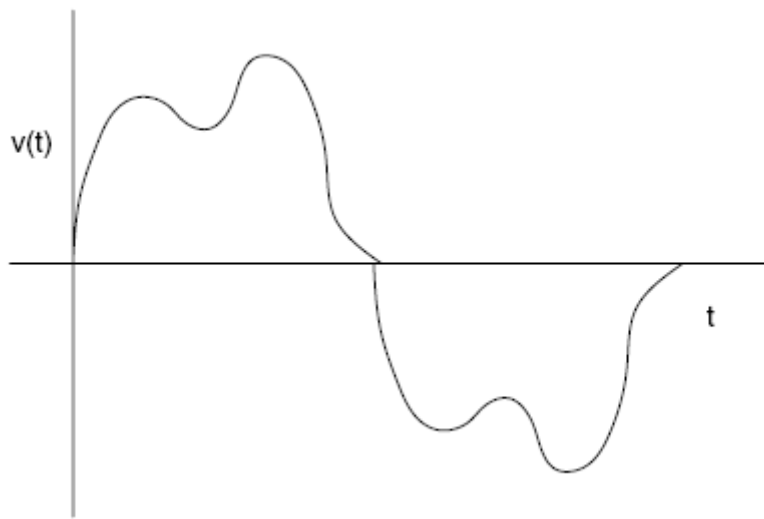

5

Figure 5: Figure 5 :

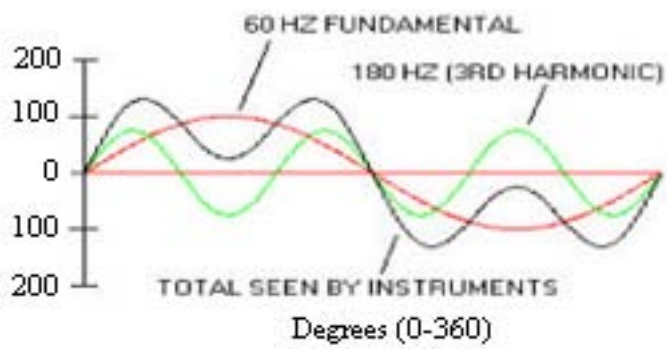

13

Figure 6: 1 . 3 -

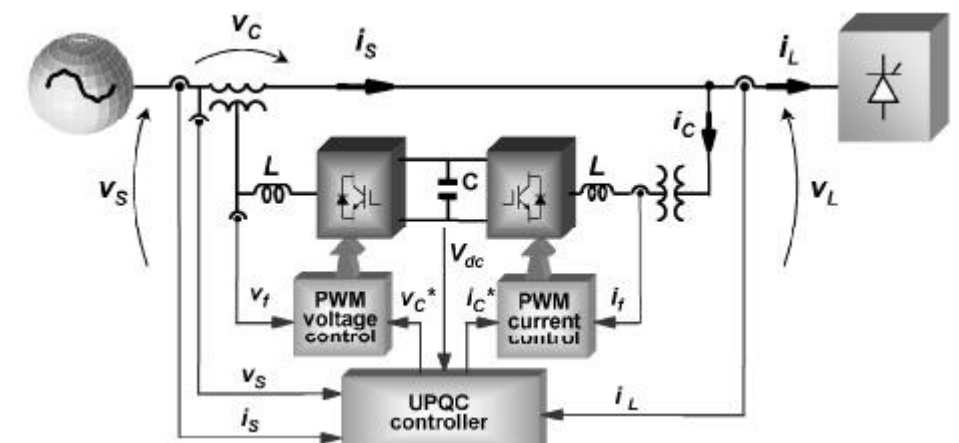

Figure 7:

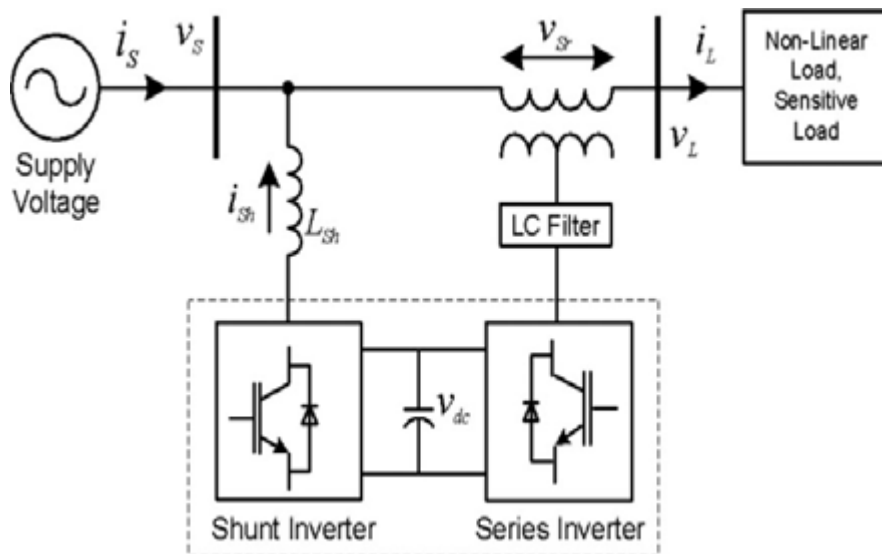
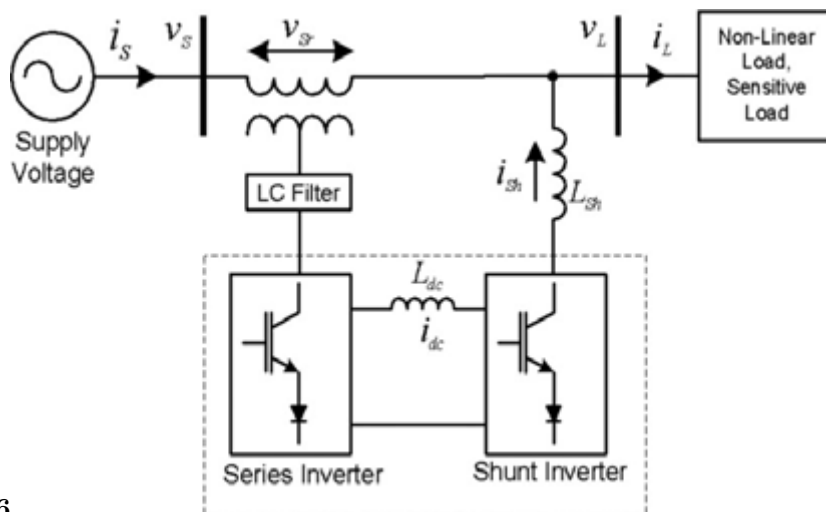

Figure 8:



6

Figure 9: Figure 6 :

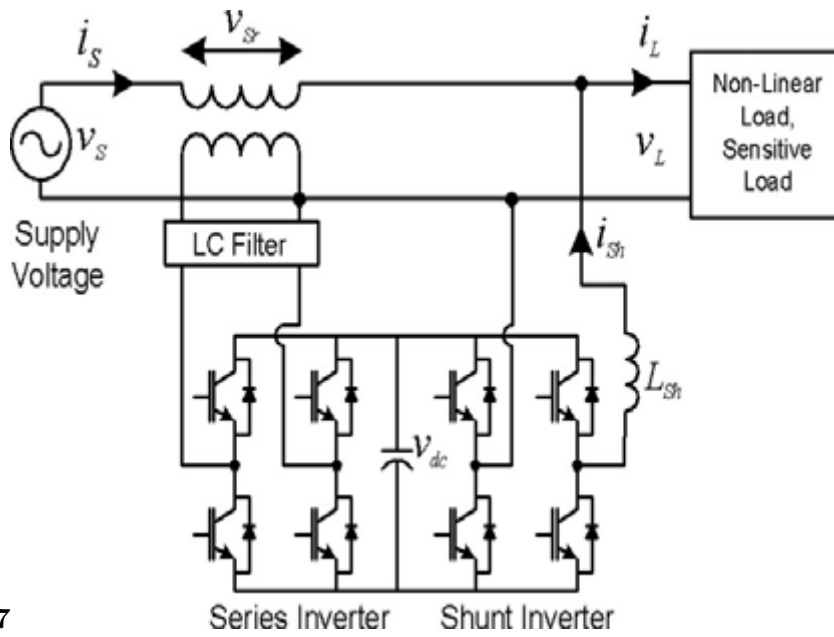

Figure 10: Figure 7 :

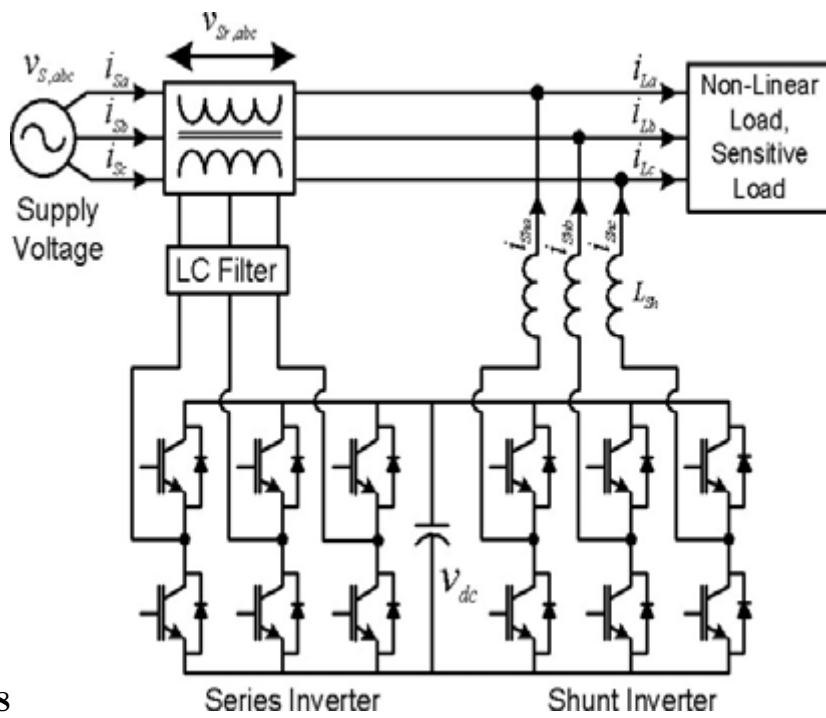
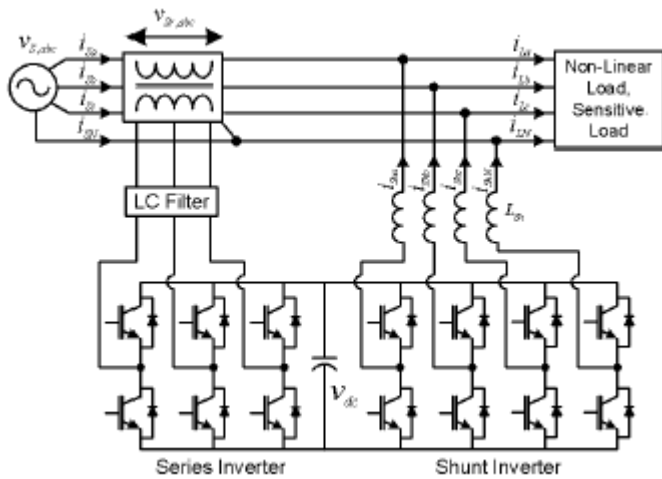

Figure 11: Figure 8 :



9

Figure 12: Figure 9 :

1

Voltage Source Inverter (VSI) based
 1. The UPQC may be developed using PWM inverter

Current Source Inverter (CSI) based
 1. The UPQC may be developed using PWM inverter

UPQC may be developed using current source

Figure 13: Table 1 :

3

Interline UPQC (UPQC-I)
 1. In Interline UPQC two inverters are connected between two distribution feeders.

Multi-converter UPQC

Multi-converter UPQC (UPQC-MC)
 1. In UPQC-MC third converter is added to support dc bus.

[Note: 2. One inverter is connected in series with one feeder while other inverter is connected in shunt with other feeder. 2. The third converter is connected either series or parallel with feeder. 3. UPQC-I can control and 3. It can control and]

Figure 14: Table 3 :

4

Multi-level UPQC
Modular UPQC
(UPQC-MD)

1. In UPQC-MD several H-bridge modules are connected in cascade in each phase.

Multi-level UPQC
(UPQC-ML)

1. UPQC-ML is based on 3-level neutral point clamped topology.

Figure 15: Table 4 :

-

1. The voltage sag is mitigated by injecting active power through series inverter of UPQC.

2. In Active Power Control P is referred as active power.

3. To compensate equal percentage of sag UPQC-P requires smaller magnitude of series injection voltage compared to UPQC-Q.

1. The voltage sag is mitigated reactive power through series inverter of UPQC.

2. In Reactive Power Control Q is referred as reactive power.

3. To compensate equal percentage of sag UPQC-Q requires larger magnitude of series injection voltage compared to UPQC-P.

by injecting

requires larger of series

The comparison between Minimum VA Loading (UPQC-VAmin) and Active-Reactive Power Control (UPQC-S) [29],[30], [31], is given in TABLE-7.

6.

Figure 16: TABLE -

Minimum VA loading (UPQC-V _{Amin})	Active & Reactive Power Control
1. This method is used which is injected certain optimal angle with respect to source current. 2. The series voltage injection and the current drawn by shunt inverter must need	Active & Reactive Power Control (UPQC-S)
Minimum VA loading of UPQC.	for determination of reactive power with shunt inverter.
V. Control Strategies of upqc	Control strategy play very important role in
system's performance. The control strategy of UPQC may be implemented in three stages:	
i.	Voltage and current signals are sensed Compensating commands in
	terms of voltage and
ii.	current levels are derived. The gating signals Switches of UPQC are generated using PWM, hysteresis or fuzzy logic based control techniques
	semiconductor
iii. In the first stage voltage	signals are sensed using power transformer or voltage sensor and current signals are sensed transformer or current sensor.
commands are mainly based on two types of domain methods: (1) Frequency domain methods, and (2) Time domain method. Frequency domain methods, which, is based on the Fast Fourier Transform (FFT) of distorted voltage or current signals to extract compensating commands. This FFT are not popular because of large computation, time and delay.	In second stage derivation of compensating

Figure 17: Table 7 :

6

and Reactive Power Control
Active Power Control
(UPQC-P)

Reactive Power Control
(UPQC-Q)

Figure 18: Table 6 :

1 Acknowledgements

- The author B. Gopal express sincere thanks to the Management, the Principal and the Staff members of the Department of EEE of Khammam Institute of Technology & Sciences, Khammam for the continued support in executing this work.
- [Capetown and Africa ()] , South Capetown , Africa . Aug.24-28,2009. p. .
- [29. V. Khadkikar, A. Chandra, A. Barry, and T ()] , *Comput. Technol* 29. V. Khadkikar, A. Chandra, A. Barry, and T (ed.) Mar. 23-24, 2011. p. .
- [Kumar and Ganesan ()] ‘250 kVA unified power quality controller’. R S Kumar , P Ganesan . *Proc. TENCON*, (TENCON) Nov. 14-17, 2006. p. .
- [Zhili et al. ()] ‘A direct control strategy for UPQC in three-phase four-wire system’. T Zhili , L Xun , C Jian , K Yong , D Shanxu . *Proc. Power Electron. Motion Control Conf*, (Power Electron. Motion Control Conf) Aug. 14-16, 2006. p. .
- [Moran (1989)] ‘A line voltage regulator/conditioner for harmonic -sensitive load isolation’. S Moran . *Proc. Ind. Appl. Soc. Annu Meet. Conf* Oct. 1-5, 1989. p. .
- [Zhili and Zhu ()] ‘A new control strategy for threephase four-wire UPQC when voltage fluctuating on its DC side’. T Zhili , D Zhu . *Proc. 2nd IEEE Int. Symp. Power Electron. Distrib. Generation Syst. un. 6-18*, (2nd IEEE Int. Symp. Power Electron. Distrib. Generation Syst. un. 6-18) 2010. p. .
- [Kazemi et al. ()] ‘A new control Strategy For unified power quality conditioner (UPQC) in distribution systems’. A Kazemi , A Mokhtarpour , M Haque . *Proc. Int. Conf. Power Syst. Technol*, (Int. Conf. Power Syst. Technol) Oct. 22-26, 2006. p. 15.
- [Singh et al. (1999)] ‘A review of active filters for power quality improvement’. B Singh , K Al-Haddad , A Chandra . *IEEE Trans. Ind. Electron* Oct. 1999. 46 (5) p. .
- [Correa et al. (2003)] ‘A single Phase high frequency AC microgrid with an unified power Quality conditioner’. M Correa , S Chakraborty , G Simoes , A Farret . *Proc. IEEE Int. Symp. Ind. Electron*, (IEEE Int. Symp. Ind. Electron) Jun.9-11, 2003. p. .
- [Hari et al.] ‘A versatile control scheme for UPQC for power quality improvement’. N Hari , K Vijayakumar , S S Dash . *Proc. Emerging Trends Electr*, (Emerging Trends Electr)
- [El-Habrouk et al. (2000)] ‘Active power filters: Areview’. M El-Habrouk , M K Darwish , P Mehta . *IEE Electr. Power Appl* Sep.2000. 147 (5) p. .
- [Cheng and Philippe ()] ‘Advanced control methods for the 3-phase unified power quality conditioner’. Y Cheng , L Philippe . *Proc. Power Electron. Spec. Conf*, (Power Electron. Spec. Conf) Jun. 20-25, 2004. p. .
- [Aredes et al. (1998)] ‘An universal active Power line conditioner’. M Aredes , K Heumann , E H Watanabe . *IEEE Trans. Power Del* Apr. 1998. 13 (2) p. .
- [Ng et al. (2004)] ‘Analysis and control of UPQC and its DC-link power by use of p-q-r instantaneous power theory’. F Ng , M C Wong , Y D Han . *Proc Power Electron. Syst. Appl* Nov. 9-11, 2004. p. .
- [Bridge Rectifier for an Isolated Power Generation International Journal of Advanced and Innovative Research (2012)] ‘Bridge Rectifier for an Isolated Power Generation’. *International Journal of Advanced and Innovative Research* August 2012. 1 (3) p. .
- [Han et al. (2006)] ‘Combined operation of unified power-quality conditioner with distributed generation’. B Han , B Bae , H Kim , S Baek . *IEEE Trans. Power Del* Jan. 2006. 21 (1) p. .
- [Srinath et al. (2010)] ‘Comparative performance of different control strategies on UPQC connected valuation of distribution system’. S Srinath , M P Selvan , K Vinoth , Kumar . *Proc. Int. Conf. Ind*, (Int. Conf. Ind) Jul. 29-Aug. 1, 2010. p. .
- [Nguyen (2006)] ‘Conceptual Study of unified power quality conditioner (UPQC)’. Nguyen . *Proc. IEEE In Symp Ind. Electron*, (IEEE In Symp Ind. Electron) Jul. 9-13, 2006. p. .
- [Zhang et al. (2007)] ‘Design of a new DC Link voltage controller for universal power quality controllers’. H Zhang , J Liu , X Huang , Z Wang . *Proc. Appl. Power Electron. Conf*, (Appl. Power Electron. Conf) Feb. 25-Mar. 1, 2007. p. .
- [Murthy et al.] ‘Internal Fault Diagnosis of HVDC Converter Transformer using wavelet Transform Technique’. P Krishna Murthy , J Amarnath , S Kamakshaiah , B P Singh . *16 th International Symposium on High Voltage*, (ISH-2009)
- [Hu and Chen (2000)] ‘Modeling and controlling of unified powe Quality conditioner’. M Hu , H Chen . *Proc. Adv. Power Syst*, (Adv. Power Syst) Oct 30-Nov. 1, 2000. p. .
- [Rafiei et al. (2009)] ‘Optimal Unified Power quality conditioner with Improved comp ensation Performance under distorted voltages’. S M R Rafiei , R Asadi , G Griva , R Bojoi . *Proc. IEEE Bucharest Power Tech*, (IEEE Bucharest Power Tech) Jun. 28-Jul. 2, 2009. p. .

14 CONCLUSION

- 254 [Gopal et al. (2011)] ‘Performance of MC-UPQC in unbalanced source voltage and voltage sag/swell migration
255 conditions’. B Gopal , K K Vasishtha Kumarand Ch , Ramulu . *ACEEE Trans. In InternationalJournal on*
256 *Recent Trends in Engineering & Technology (IJRTET)* Mar, 2011. 05 (02) p. .
- 257 [Gopal et al.] *Power Quality Improvement using 24 pulse*, B Gopal , P Krishna Murthy , G N Srinivas .
- 258 [Mastromauro et al. (2007)] ‘Single-phase Grid connected photovoltaic systems with power quality conditioner
259 functionality’. R Mastromauro , M Liserre , A Dell’aquila . *Proc. Power Electron. Appl*, (Power Electron.
260 Appl) Sep. 2-5, 2007. p. .
- 261 [Muthu and Kim ()] ‘Steady-state operating Characteristics of unified active power filters’. S Muthu , J M S Kim
262 . *Proc. Appl. Power Electron. Conf*, (Appl. Power Electron. Conf) Feb. 23-27, 1997. p. .
- 263 [System (2008)] System . *IEEE Region 10 colloquium and the third ICIIS*, (Kharagpur, India) Dec.8-10, 2008.
264 p. .
- 265 [Fujita and Akagi (1998)] ‘The unified power quality conditioner: The Integration of series and shuntactive
266 filters’. H Fujita , H Akagi . *IEEE Trans. Power E1electron* Mar. 1998. 13 (2) p. .
- 267 [Chen et al. ()] ‘Three-phase four-leg Active power quality conditioner without references calculation’. G Chen ,
268 Y Chen , K M Smedley . *Proc. Appl. Power Electron. Conf*, (Appl. Power Electron. Conf) 2004. p. .
- 269 [Akagi (1994)] ‘Trends in active power line conditioners’. H Akagi . *IEEE Trans. Power Electron* May 1994. 9
270 (3) p. .
- 271 [Jianjun et al. ()] ‘U nified power quality conditioner (UPQC): The principle, control and application’. G Jianjun
272 , X Dianguo , L Hankui , G Maozhong . *Proc. Power Convers. Conf*, (Power Convers. Conf) 2002. p. .
- 273 [Farokhnia et al. ()] ‘Voltage sag And Unbalance mitigation in distribution systems using multi-level UPQC’. N
274 Farokhnia , S H Fathi , H R Toodeji . *Proc. Power Quality Conf*, (Power Quality Conf) Sep. 14-15, 2010. p. .
- 275 [Murthy et al.] *Wavelet Transform approach for Detection and Location of Faults in HVDC*, P Krishna Murthy ,
276 J Amarnath , S Kamakshaiah , B P Singh .