

# Tunable Multiband Micro S trip Antenna for 5ghz Wlan

Ali Ejaz<sup>1</sup>, Dr. R. Nilavalan<sup>2</sup> and Hattan Abutarboush<sup>3</sup>

<sup>1</sup> Brunel University

*Received: 12 December 2012 Accepted: 3 January 2013 Published: 15 January 2013*

---

## Abstract

In this paper, a tunable Multiband Micro strip Antenna is designed, capable of tuning its operating frequency in 5GHz band independently. Two slots of E U shape are etched to achieve multiband resonance. Two capacitors of fixed value and a varactor diode are used to achieve tuning. Proposed antenna targets the 5GHz WLAN bands; UNII-1 and UNII-2. Simulated and measured results are in good agreement.

---

**Index terms**— reconfigurable antenna, fr reconfigurability, variable reactive loading, 5ghz Wlan.

## 1 INTRODUCTION

ORLDLY spectrum regulatory bodies have developed standards for the use of frequency spectrum and most applications are allocated fixed licensed frequency bands to operate; one has to pay in order to use licensed bands. On the contrary certain free of cost unlicensed frequency bands are also available for use such as ISM (Industrial, Scientific and Medical) Band is reserved internationally for the use of radio frequencies for industrial, scientific and medical purposes. At present 2.4 GHz ISM band is the most adopted unlicensed band available in the world; in most countries it ranges from 2.4 to 2.483 GHz. Wireless LAN IEEE 802.11b/g/n is a common application that uses 2.4 GHz ISM band. Beside WLAN, Bluetooth technology, IEEE 802.15.4/Zigbee, cordless phones, microwave ovens, other industrial & home used appliance operates in 2.4 GHz ISM band. Being widely used by many technologies; 2.4 GHz band has become increasingly crowded and interference has become inevitable. Interference problem can be reduced by effective frequency planning or via using an alternative unlicensed frequency band [3][4][5][6].

Recently USA & Canada have developed 5 GHz WLAN standards; the band is divided into several subbands named as Unlicensed National Information Infrastructure (UNII) bands. The UNII-1 band is designated for indoor operations, the UNII-2 and UNII -2 extended bands are for indoor and outdoor operations, and the UNII-3/ISM band is intended for outdoor bridge products and may be used for indoor WLANs as well. Table-1 shows the frequency range and number of channels for each 5 GHz UNII bands [4].

Author ? ? ? : School of Engineering & Design, Brunel University, Uxbridge, Middlesex, UB8 3PH, UK. E-mails : mmaliejaz@hotmail.com, Rajagopal.Nilavalan@brunel.ac.uk, Hattan.Abutarboush@kaust.edu.sa Table ?? : 5 GHz WLAN Bands A reconfigurable antenna is the one that has selectable or tunable fundamental characteristics that includes operating frequency, radiation pattern, and polarization. In general, the objective is to alter one or more of these characteristics independently of the others. Methods being used to vary the parameters are electrical, mechanical, or electromechanical in nature. Depending upon the primary antenna parameters, reconfiguration mechanism can be classified into three major categories which are; frequency response reconfigurability, radiation pattern reconfigurability and polarization reconfigurability. In frequency response (FR) reconfigurability, antenna varies its resonant frequencies; this variation can be continuous or discreet depending upon the technique employed. There are several possible means to achieve FR reconfigurability such as switches, variable reactive loading, mechanical changes or material changes. The electric methods involves the use of switches such as Pin diode, MEMS, FET switches; cause discrete change in resonant frequency; and variable reactive loading technique that make use of varactor diode that yields continuous tuning of resonant frequency [1].

In this paper, FR reconfigurability is exercised using variable reactive loading technique. Hence, a tunable micro strip antenna has been designed which can operate in multiple frequency bands and capable of altering

## 9 CONCLUSION

---

47 one of its resonant frequencies independently. Proposed antenna has the advantage of being light weight, slim,  
48 small in size, cost effective, easy to fabricate and simple structure targeting small portable device to be used in  
49 years to come.

50 The objective is to achieve FR reconfigurability and implication in achieving it lies in the fact that resonant  
51 frequencies are closely related to each other [1]. This means, in case of multiband frequency response; efforts  
52 make to change one frequency might vary other frequencies too. Therefore question arises, how is it possible to  
53 isolate resonant frequencies from each other to achieve independent tuning? Effective electrical length ( $l_{eff}$ ) of  
54 an antenna determines its resonant frequencies [2]. Therefore, key lies in identifying the part of slotted patch,  
55 responsible for a particular resonant frequency and then varying the effective electric length accordingly. This  
56 is done via performing parametric study and investigating surface current distribution (SCD) of antenna for all  
57 resonant frequency bands. Tuning is obtained by adding variable capacitance to the design. Varactor diode  
58 behaves like a variable capacitor if its reverse biased voltage varies. This property of varactor diode is exploited  
59 here and its introduction to design causes effective electrical length of the antenna to vary, and in turn results in  
60 tuning of resonant frequency of antenna.

## 61 2 II.

## 62 3 DESIGN PROCEDURE

63 Initially, multiband micro strip antenna of rectangular patch is designed on a substrate material FR-4 of size  
64 ( $35 \times 35 \times 1.57$ ) mm with dielectric constant  $\epsilon_r = 4.4$ , micro strip feed line method is used to feed the antenna  
65 and E & U shape slots are etched in the patch to achieve multiband frequency response. Fig. ?? shows the  
66 geometry of purposed antenna. And Fig. ?? shows the simulated S11 of the proposed antenna where multiple  
67 bands were achieved at 3, 4 and 5 GHz. In order to investigate the independency of three frequency bands,  
68 variations in some effective parameters such  $L_p$ ,  $W_p$  and size of E & U-slot were done. The results yielded  
69 from parametric study are as follows: The application, I have intended to target here is 802.11 5GHz WLAN;  
70 therefore this paper only takes account of 5GHz band. Consequently simulation results of parametric study  
71 related to 5GHz band are provided. After observing that variation in E-slot varies the resonant frequency in  
72 5GHz band, next step is to investigate SCD for all bands in order to locate a position on patch where integration  
73 of varactor diode could yield independent tuning. Fig. 4 shows that current distribution for 5GHz band is along  
74 E-slot.

## 75 4 IMPLEMENTATION PROCEDURE a) Implementation

76 After completing design and obtaining optimum simulation results on HFSS, hardware implementation is  
77 accomplished using Lab facilities at Brunel University, UK. Fig. 8 shows the actually implemented antenna.

## 78 5 c) Simulation Vs Measured Results

79 Upon comparing results depicted in fig. 6 and fig.9, it can be observed that antenna has multiband ( ) resonance  
80 and independent tuning of 5GHz band is achieved practically. Only difference among the results is; implemented  
81 antenna is not resonating in 4GHz band effectively. The possible reasons behind this are as follows [7]: i.  
82 Substrate Material In micro strip antennas dielectric constant  $\epsilon_r$  and substrate thickness  $h$  have great impact  
83 on antenna parameters and deviations from the specified values alter the resonating frequencies.

84 ii. Antenna Production Problems While antenna fabrication etching errors and stress relief after etching affects  
85 physical dimensions of antenna. Hence deviations from ideal results may occur in frequency response.

86 iii. Components Effect Exposure of varactor diode to extensive heat while soldering on antenna patch may  
87 affect its working that may cause deviation from desired results.

## 88 6 iv. Connecting Wires Effect

89 Conductors exhibits capacitive or inductive behaviour at high frequencies. Thus connecting wires, supplying dc  
90 reverse bias voltage to diodes may also have impact on resonant frequency of antenna.

## 91 7 IV.

## 92 8 PROPOSED APPLICATION

93 Implemented antenna is capable of tuning its operating frequency in 5GHz band; ranges from 5.09 to 5.46 GHz.  
94 That covers the frequency range of UNII-1band (5.17 to 5.24 GHz) and UNII-2 band (5.25 to 5.35 GHz) with  
95 ease. V.

## 96 9 CONCLUSION

97 Effort has been made to design and implement a reconfigurable multiband micro strip antenna. There are several  
98 kinds of reconfigurability and various possible means to achieve them. But in this work frequency response  
99 reconfigurability is exercised using reactive loading method. A rectangular patch antenna is designed using

100 substrate material FR-4 of size (35×35×1.57) mm<sup>3</sup> with  $\epsilon_r = 4.4$  and E & U-slots are etched to achieve  
 101 multiband resonance. Then varactor diode, having capacitance range 0.6pF to 8.5pF and reverse biased voltage  
 102 range 30V to 0V, integrated on the patch. Change in reverse biased voltage causes capacitance of the diode to  
 103 vary that in turn alters the effective electrical length ( $l_{eff}$ ) of the antenna. As resonant frequency of the antenna  
 is associated with its ( $l_{eff}$ ), therefore continuous change in it results in tuning of resonant frequency. <sup>1 2 3 4</sup>



12

Figure 1: Fig. 1 (Fig. 2 :

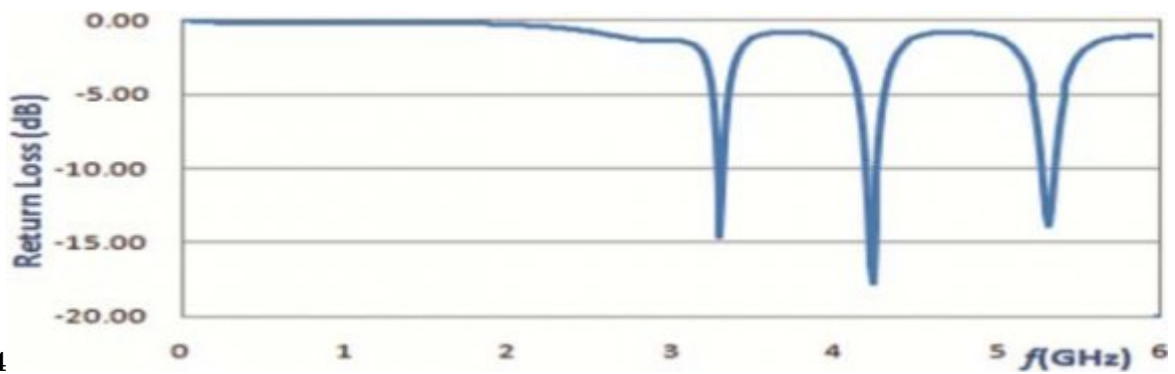

4

Figure 2: Fig. 4 :

104

<sup>1</sup>© 2013 Global Journals Inc. (US)

<sup>2</sup>Tunable Multiband Micro strip Antenna for 5ghz Wlan

<sup>3</sup>Tunable Multiband Micro strip Antenna for 5ghz Wlan (c)F

<sup>4</sup>Tunable Multiband Micro strip Antenna for 5ghz Wlan



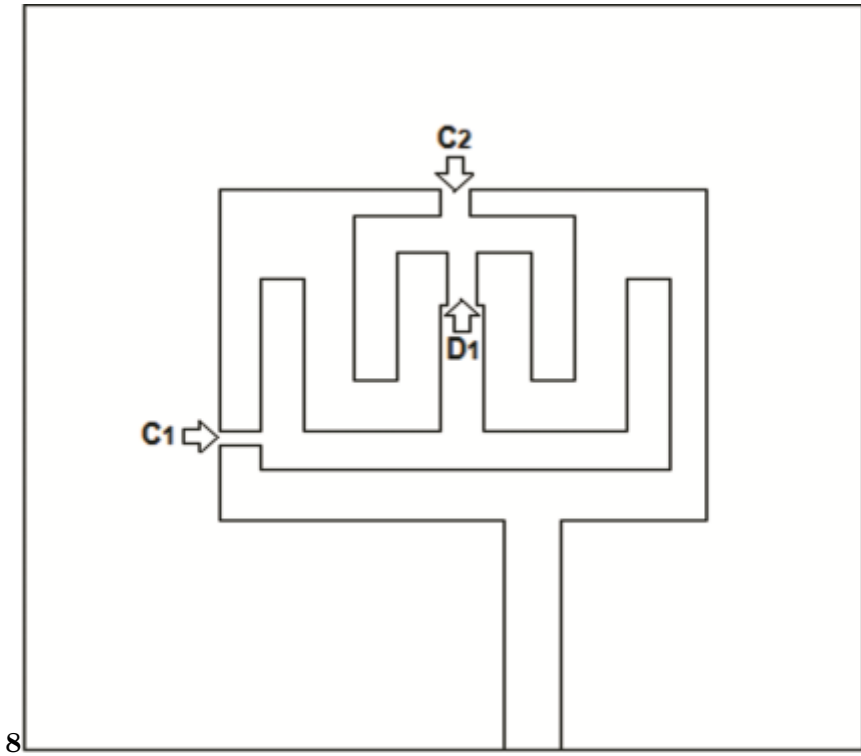

8

Figure 4: Fig. 8 :

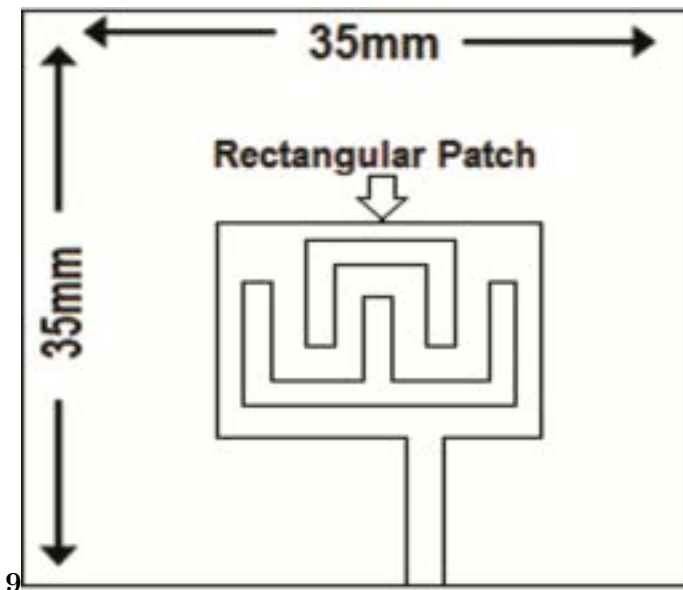

9

Figure 5: Fig. 9 :



- 
- 105 [Bernhard and Antennas ()] , J T Bernhard , Reconfigurable Antennas . 2007. Morgan & Claypool.
- 106 [Balanis ()] C A Balanis . *ANTENNA THEORY ANALYSIS AND DESIGN, Third*, 2005. John Wiley & Son,  
107 INC.
- 108 [Dynamic Frequency Slection for 5 GHz WLAN in the USA and Canada, FCC regulations update ()] *Dynamic*  
109 *Frequency Slection for 5 GHz WLAN in the USA and Canada, FCC regulations update*, 2007.
- 110 [James] P S H A C W J R James . *Microstrip Antenna Theory and Design*, (New York) London. 12.
- 111 [Ming-Ju ()] ‘RF challenges for 2.4 and 5 GHz WLAN deployment and design’. H Ming-Ju . *Wireless*  
112 *Communications and Networking Conference*, 2002. WCNC2002. 2002 IEEE, 2002. 2 p. .
- 113 [Kammerman and Aben ()] ‘Throughput performance of wireless LANs operating at 2.4 and 5 GHz,” in Personal,  
114 Indoor and Mobile Radio Communications’. A Kamerman , G Aben . *The 11th IEEE International Symposium*  
115 *on*, 2000. 2000. 2000. 1 p. .
- 116 [Behzad ()] ‘Wireless -LAN radio design and IEEE standards’. Arya Behzad . *Communication, networking and*  
117 *broadcasting conference*, 2012. p. W1273.