

# New Biogas Renewable System for Combined Sofc-Electricity Generation with a Membrane Reactor

Zoe Vasileiadou

*Received: 10 December 2011 Accepted: 1 January 2012 Published: 15 January 2012*

---

## Abstract

This paper presents and analyzes a new biogas based catalytic reforming-processing system for the conversion of gaseous hydrocarbons (coming from manure type anaerobic digesters) such as methane into hydrogen and carbon oxide mixtures. The exit synthesis gas (syn-gas) is introduced to power effectively high temperature fuel cells such as SOFC types for combined efficient electricity generation. Moreover, this research targets on the description and design aspects of permreactors (permeable reformers) carrying the same type of renewable-biogas reforming reactions. The goals of such a research include turnkey system and process development for the biogas based power generation and fuel cell industries. The proper utilization of biogas and waste type resources (coming from manure type anaerobic digesters) for green-type/renewable power generation with increased processing capacity and efficiency via SOFCs is introduced as well. Pollution reduction is under additional design benefit in the described catalytic processors-fuel cell systems, at the same time. Three different reactor configurations are examined and compared. The use of a membrane reformer and of a catalytic membrane reformer offer better hydrogen and syngas yields and methane conversions than the corresponding non-membrane plug flow reactor.

---

**Index terms**— biogas reforming, fuel cell, membrane reactor, catalytic reactor, SOFC, renewable energy.

## 1 Introduction

In our earlier IASTED and ACS presentations (PGRES '02, Marina Del Ray, CA; Modeling and Simulation, '03, Palm Springs, CA; ACS-Fuel Chemistry '02, Boston, MA) we discussed about preliminary findings and results of catalytic processors for the steam reforming of methane, natural gas, and biogas, for use in fuel cell systems such as SOFC types [1].

The recent communication continues this research introducing the so-called "Biogas power" and "Bio-Energy" systems. The use of biogas mixtures (manure based generated feedstocks) as sources for electricity and heat generation using fuel cells of the SOFC type are studied here. Use of manure based gases rich in methane coming from anaerobic digesters, for the production of intermediate synthesis gas is an Author ? : International Hellenic University, Thessaloniki, GR, 57001. E-mail : bookeng@hotmail.com attractive route in "green power" and "biogas/manure energy" based systems [2]. There is a recent emphasis on the development and commercialization of such SOFC systems for electricity and heat generation applications. Such installations begin to exist currently mainly in US, Europe, Japan, China and other developing countries. Fig. ?? below, shows the itemized distribution of biogas energy-applications which is coming from various renewable sources [3].

Fig. ?? shows the products that are coming from the biomass treatment process, especially those coming from the anaerobic digestion. In our case however the feedstock is animal wastes and not agricultural or forest biomass.

Such biomass-energy systems require the development and use of an effective catalytic reformer utilizing active metals such as Ni, Rh, Cr, or bimetallic combinations of those. Earth metal enrichment in the catalyst such as with Ca, Mg, La and K promotes the catalyst stability on stream and minimizes deactivation from carbon deposition, especially in the reactor inlet [1, ??,4,5].

45 The reformer used can be a fixed bed catalysis reactor or a permreactor using membrane type materials as  
 46 reactor walls. Use of a permreactor creates a two outlet reaction system which carries the synthesis gas product  
 47 at different compositions. The permeate stream is richer in hydrogen and less rich in carbon oxides, by the use  
 48 of hydrogen selective membranes such as microporous inorganics (e.g., alumina, titania based) or metal alloys  
 49 (Pd/Ag, Pd/Cu). One or both of the outlet gas streams can be used as feed in the accompanied fuel cell/SOFC.  
 50 Use of the permreactor increases the conversion of the reactant biogases in the reactor due to the separation  
 51 of products. This increased shift in conversion yields the required quantity of synthesis gas product for the  
 52 fuel cell at a lower operation temperature than the counterpart fixed bed (impermeable) reactor [??]. Process  
 53 operation at a lower temperature is beneficial for increasing the reactor and catalyst life time and for reducing  
 54 the endothermic heating load (Btu/hr) of the endothermic reformer. Below, we give design emphasis in both  
 55 reformer configurations for the generation and delivery of hydrogen rich synthesis gas into the accompanied solid  
 56 oxide fuel cell.

57 The traditional process utilizes directly the biogas via a turbine or an engine for heat and electricity generation  
 58 without the use of a reformer. However, the process is of low efficiency with a high waste heat rate.

## 2 II.

### 3 Fuel Cell Analysis

61 The process of reforming methane or higher hydrocarbons with steam is a key catalysis and reaction route for  
 62 producing high quality hydrogen or synthesis gas for further use, in an economical way [1, ??,4,5]. Synthesis  
 63 gas usually contains hydrogen mixed with carbon monoxide and possibly carbon dioxide as well. The reforming  
 64 processes taking place are endothermic and use similar catalysis metals as those described above.

65 Use of biogas based feedstocks as the reactant gases constitute for a methane (CH<sub>4</sub>) rich feed in the reformer  
 66 which is converted with steam into a H<sub>2</sub> and CO rich mixture. The exit hydrogen-rich gas is used as direct fuel  
 67 in the anode of the solid oxide fuel cell. The reactions of methane steam reforming and water gas shift take place  
 68 in the reformer by adding steam in the feedstock as the oxidant [2, 4,5].  

$$\text{CH}_4 + \text{H}_2\text{O} \rightarrow \text{CO} + 3\text{H}_2 \quad (\Delta H_{298} = +206.1 \text{ kJ/mol}) \quad (1)$$

69  
 70 (methane -steam reforming reaction)  

$$\text{CO} + \text{H}_2\text{O} \rightarrow \text{CO}_2 + \text{H}_2 \quad (\Delta H_{298} = -41.15 \text{ kJ/mol}) \quad (2)$$
  
 71 (water gas shift reaction)

72 Here we assume that the biogas has been purified before entering into the reformer from the various impurities  
 73 (e.g., halogens) to avoid among others the deactivation of the catalyst. Further, the contained carbon dioxide  
 74 and any hydrogen sulfide gases can be separated before the reformer, so that only pure methane is reformed  
 75 catalytically [??,6]. However, some CO<sub>2</sub> can be flown within the reactor and reformed catalytically together  
 76 with methane [??].

77 The catalyst used in the process was in the form of particles of 0.92mm average diameter. The catalyst was a  
 78 15% NiO on alumina enriched with calcium and magnesium to withstand deactivation from carbon deposition.  
 79 8.03gr of catalyst was loaded in the reformer.

80 The interconnected solid oxide fuel cell (SOFC) produces electricity by the electrochemical oxidation of both  
 81 hydrogen and carbon monoxide gases, following a dual electrochemical reaction mechanism [??]. Part of the hot  
 82 gas exiting from the fuel cell can be diverted in the shellside of the membrane reactor in a closed loop, to provide  
 83 the necessary endothermic heat for running the reformer.  

$$\text{H}_2 + \text{O}^{2-} \rightarrow \text{H}_2\text{O} + 2e^-$$
  

$$\text{CO} + \text{O}^{2-} \rightarrow \text{CO}_2 + 2e^-$$

84 In the SOFC cathode:  

$$\text{O}_2 + 4e^- \rightarrow 2\text{O}^{2-}$$

85 With the overall reaction to be:  

$$\text{H}_2 + \text{CO} + \text{O}_2 \rightarrow \text{CO}_2 + \text{H}_2\text{O} \quad (3)$$

86 Mathematical modeling of the CH<sub>4</sub>-H<sub>2</sub>O reformer for a steady state fixed-bed catalytic reactor includes the  
 87 species reaction terms in the mass balance equations. Moreover the thermal and momentum balances are also  
 88 written for a non-isothermal reformer with pressure drop along its catalyst bed [??]. A detailed analysis of the  
 89 model, its parameters and their variation is given in earlier communications [??]. The system of these equations  
 90 is integrated numerically as an initial value problem to provide the reactant conversions, product yields, reactor  
 91 temperature and pressure along the axial length and to obtain the axial profiles of these variables and their values  
 92 at the reactor exit.

93 By employing an inorganic permreactor as the main catalytic processing unit to convert manure biogas  
 94 feedstocks into fuel cell gas, the above design equations are modified accordingly to include the permeation effects  
 95 of the different gases via the membrane. In our experimental reaction studies we utilized mesoporous aluminum  
 96 oxide membranes having a thin permselective layer (3-5 μm thickness, 50% porosity) with 40-50Å pore diameter  
 97 [1, ??]. The membranes are multilayer structures having at the end a support layer. The separation of the gases  
 98 through the membrane follows primarily the Knudsen diffusion. In the case of a permreactor the corresponding  
 99 mass, temperature, and pressure variation equations are written as well for the gas which permeates via the  
 100 membrane wall material and flows in the permeate side (S) of the membrane reactor. The detailed model for the  
 101 permreactor has been described in our earlier communications [??].

102 By using the above equations within the modeling procedure a detailed reactor analysis is obtained for the  
 103 two different reformer configurations. Solution of the equations is obtained numerically by using an initial value  
 104 integration technique for ordinary differential equations with variable stepsize to ensure higher accuracy (implicit  
 105 Adams-Moulton method) [??].

---

106 In our previous communications we have described and analyzed the reaction, separation (i.e., permeation),  
107 and process (conversion, yield) characteristics of permreactors (membrane based catalytic reactors) and related  
108 processes for methanesteam reforming, water gas shift, and methane-carbon dioxide reforming reactions  
109 including catalysis and membrane materials characteristics [1, 2]. These effective and versatile catalytic systems  
110 were applied for pure hydrogen ( $H_2$ ),  $H_2$  and  $CO_2$ , and  $H_2$  and  $CO$  (syn-gas) generation to be used as fuel  
111 gas for power generation or as synthesis gas for production of specialty chemicals (such as methanol and higher  
112 hydrocarbons) [1, 2].

113 The interconnected or integrated solid oxide fuel cell is fed directly by the fuel gas generated by the described  
114 reformers. The focus of our studies includes solutions in a number of problems associated with the installation,  
115 operation, and mass, energy conservation of the entire fuel cell and membrane-processing unit. The economic  
116 feasibility of the overall fuel cell installation is correlated with high efficiency (e.g., 50%-75% for advanced units)  
117 and high current density output ( $A/cm^2$ ), increased system reliability for continuous dispersed power generation,  
118 and reduced plant installation, operation and maintenance cost. These targets combined with virtual elimination  
119 of pollution by use of fuel cells in stationary (e.g., central and remote power stations) and mobile/transportation  
120 (e.g., automobile) sources make this technology highly applicable and attractive. Clean fuel cell power minimizes  
121  $NO_x$ ,  $CO$ , and hydrocarbon species in the emissions [2].

## 122 4 III.

## 123 5 Results and Discussion

124 The apparatus used in the experiments consists of mass flow controllers, a bubbler to generate steam for the  
125 reaction, the reactor housing wherein the plug flow reactor or the membrane reactor was placed. The apparatus  
126 with its details is shown in Fig. 2. The reactor is equipped with thermocouples to read the temperature and  
127 with pressure transducers to read the pressure. At the exit of the reactor the apparatus consists of steam traps  
128 and a gas chromatograph to analyze the exit stream. The gas chromatograph operates in the TCD mode and is  
129 equipped with a porapak Q column for the gas analysis.

130 The idea of biogases utilization, coming from manure-type anaerobic digesters, within the reformer, constitutes  
131 an innovative approach in previous attempts for direct use of those feedstocks for power generation [6]. There are  
132 important renewable resources of biogas feedstocks today generated from the large herds of farm animals grown  
133 in local and remote farms.

134 The gas that exits from the proper treatment of manure in anaerobic digesters is rich in methane and carbon  
135 dioxide, and constitutes the proper mixture for direct conversion into the described reformer/SOFC system. As  
136 the flowrate of the manure biogases increases (for larger sites and treatment systems) a larger capacity reformer  
137 and fuel cell are required to handle the conversion; consecutively, the final SOFC power output ( $kW/cm^2$ )  
138 increases as well.

139 The table 1 shows the percentage of income from the direct utilization of biogases coming from agricultural  
140 and farm animal waste sources. It shows the different energy utilization of used biogas in terms of percentage  
141 [3].

142 Fig. 1 is a useful flowchart of the biomass conversion process. It includes the anaerobic digestion process  
143 which yields methane and synthesis gas products.

144 The schematic of the experimental apparatus wherein the conversion to synthesis gas is taking place is shown  
145 in details in Fig. 3.

146 The performance of two types of reformers for the specific reactions is described. Hence, Fig. 4 shows the total  
147 hydrogen yield produced from these reactions within the reformer and specifically at the reformer exit as function  
148 of the reaction temperature. We report results from a membrane type reformer and from a conventional (non-  
149 membrane) plug flow type reformer. The membrane reformer exceeds the non-membrane reformer in the total  
150 hydrogen yield and this is also shown by the accompanied modeling results which simulate well the experimental  
151 membrane reformer data. Moreover, the plug flow type reformer produces results that are very close to the  
152 calculated equilibrium hydrogen yields which are calculated at the tubeside (T) reaction conditions. Hydrogen  
153 produced under these conditions is directed in the fuel cell anode to drive the electrochemical reactions discussed  
154 above. The feed composition in the tubeside of the membrane reformer was maintained at  $CH_4 : H_2O : Ar : H_2 = 1 : 7 : 1 : 0.75$ . Ar gas was added initially in the feed as a diluent to examine the effect of diluting the  
155 methane/biogas feed. The space time of the reactor tubeside was maintained at 54.0 gr cat .hr/gmole  $CH_4$ .  
156 The reaction temperature range examined in the two reactors was varied from 450-590 o C. The pressure in the  
157 tubeside of the reformers where the catalyst lies was maintained at about 2-3 psig (1.17atm) during the course  
158 of the experiments.

159 Methane conversion data at various reactor space times are included as well. This data is indicative of the  
160 performance of the catalytic methane steam reforming reaction within the reformers. The reaction conditions  
161 remained the same as with the above plot (hydrogen yield data).

162 Thus, Fig. 5 below, shows methane conversion versus space time data for the production of  $H_2$  and  $CO$   
163 syngas (fuel gas). The operation took place at a constant temperature of 550 o C. The data is referred to two  
164 types of reformers and it is accompanied by simulation fittings by the numerical models developed and described  
165 above. It is interesting to notice that the membrane reactor data exceeds both the plug flow reactor and the  
166

equilibrium conversion data. The membrane reactor therefore produces more hydrogen and syngas for the joint fuel cell system (SOFC) at various methane inlet flowrates.

indicative of the extent of the water gas shift reaction (reaction (2)). The CO<sub>2</sub> yield also corresponds to the CO conversion according to reaction (2). As one can observe, there is a good agreement by the modeling results (simulation lines) to the experimental CO<sub>2</sub> yield data. The reaction conditions are the same with those described above. The above plots (Figs. ??, 4, 5) are shown the type of syngas (in terms of composition) which is entering into the SOFC system for electricity generation according to reactions (3), [1, ??].

The included data shows that fuel gas rich in H<sub>2</sub> and CO compounds can be produced from the described reformers and especially from the membrane reformer for the continuous operation and electricity generation of the SOFC. Another related plot is shown in Fig. ?. It shows the generated power by the SOFC for various feed ratios and reforming conditions (i.e., reaction temperature, inlet feed composition). The plot assumes a 60% fuel cell efficiency at equilibrium fuel gas composition according to reactions (1) and (2). As the steam to methane ratio is increased in the inlet the power output is increased as well. Higher power outputs (kW) can be achieved usually between 600-800°C.

Finally, Table ?? below presents a summary of specifications from a medium biogas processing plant (farm-animal wastes plant) for energy cogeneration. The table shows details on the energetic distribution outcome of the entire plant (e.g., 60% electricity generation efficiency for the SOFC). The data refers to 4,420 swines as the total number of farm animals. This table is included for comparison purposes, in order to provide the potential of the newly described biogas to SOFC unit. It is important to say that the electricity generated by the SOFC (assuming a 60% efficiency) can cover the needs of the farm and any excess electricity can be sold in the nearby electrical network. Moreover, the useful heat from the SOFC can cover the heating needs of the farm (e.g., via a boiler) and those of the endothermic reformer.

Two more figures are also shown below for the so-called PBCMR configuration. In these plots the membrane was also rendered catalytic by the incipient wetness method. A solution of NiNO<sub>3</sub> was used to impregnate the ceramic membrane tube. The data shown in Figs. ?? and 8 was taken under these conditions. It is important that the PBCMR (packed bed catalytic membrane reactor) exceeds substantially in both conversion and yield the CPFR (catalytic plug flow reactor) data. The PBCMR data are also higher than the equilibrium calculated conversions and yields. These facts are attributed to the use of the catalytically impregnated membrane as the reactor of the system. The feed composition in the tubeside of the membrane reformer was maintained at CH<sub>4</sub> : H<sub>2</sub> O : H<sub>2</sub> = 1 : 4 : 0.20. The space time of the reactor tubeside was maintained at about 50.0 gr cat .hr/gmole CH<sub>4</sub>. The reaction temperature range examined in the two reactors was varied from 475-550°C. The pressure in the tubeside of the reformers where the catalyst lies was maintained at about 10 psig (1.68atm) during the course of the experiments. The developed computational model for the PBCMR shows a pretty good agreement with the experimental membrane reactor data. Thus, the catalytic impregnation of the membrane is an additional advantage of the described system by offering higher hydrogen yields and methane conversions.

IV.

## 6 Conclusions

In this paper, it is shown that the operation of high temperature SOFCs/fuel cells can be coupled with reforming reactors of biogases. The SOFCs can operate in series or integrated with a catalytic reformer or a membrane reformer which convert biogas into fuel gas at various operating conditions. Biogases are rich in CH<sub>4</sub> and are converted catalytically into a H<sub>2</sub> and CO mixture suitable for the continuous operation of the SOFC unit. Our reactors have been also simulated by computational models which account for the reaction and hydrogen separation in the permeable reformers. Various operating conditions in the permeable reformers have been tested by these models. The membrane based permreactor has shown to offer better hydrogen yields and better methane conversions than the counterpart fixed bed based reactor. Among the membrane reactors examined the PBCMR found to perform superior than the simple (non-catalytic) membrane reactor. This happens most probably due to the catalytic membrane contribution as well.

Essential distributed power generation within a wider power grid can be accomplished through this design, which can cover the local needs of municipal and remote areas. Fuel cell power relates to the reformer conversion and the efficient utilization of the syngas by the fuel cell. In addition, the waste heat from the conversion of syngas to electricity can be decreased with the fuel cell operation, especially with this of high efficiency SOFCs. Moreover, fuel cell/SOFC continuous operation and power generation from biogases contribute to the pollution minimization, higher power density and efficiency in comparison with conventional power operations. With the use of clean SOFC power, we can also minimize NO<sub>x</sub>, CO, and hydrocarbon species from the emissions of such stationary biogas power construction.

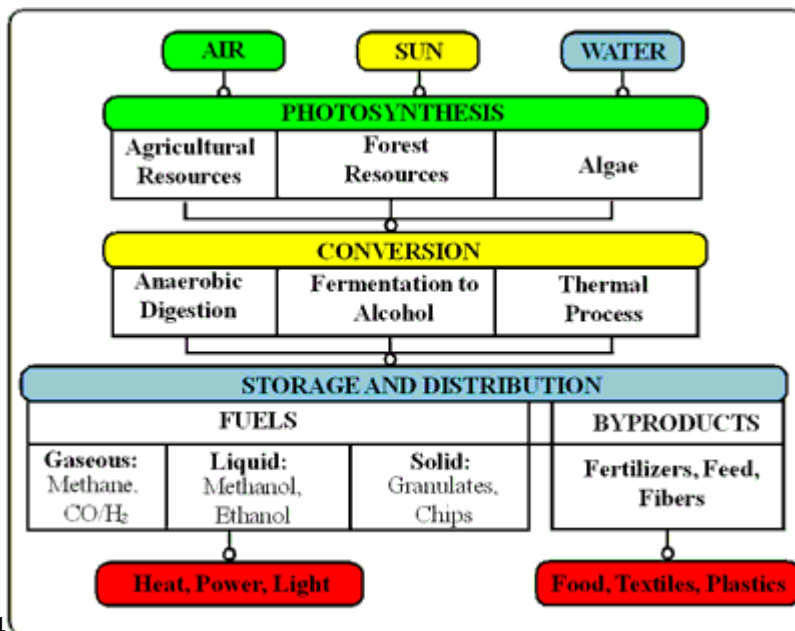
Table ?? : Percentage of income from the direct utilization of biogas coming from agricultural sources and animal wastes [3].<sup>1</sup>

---

<sup>1</sup>© 2012 Global Journals Inc. (US)

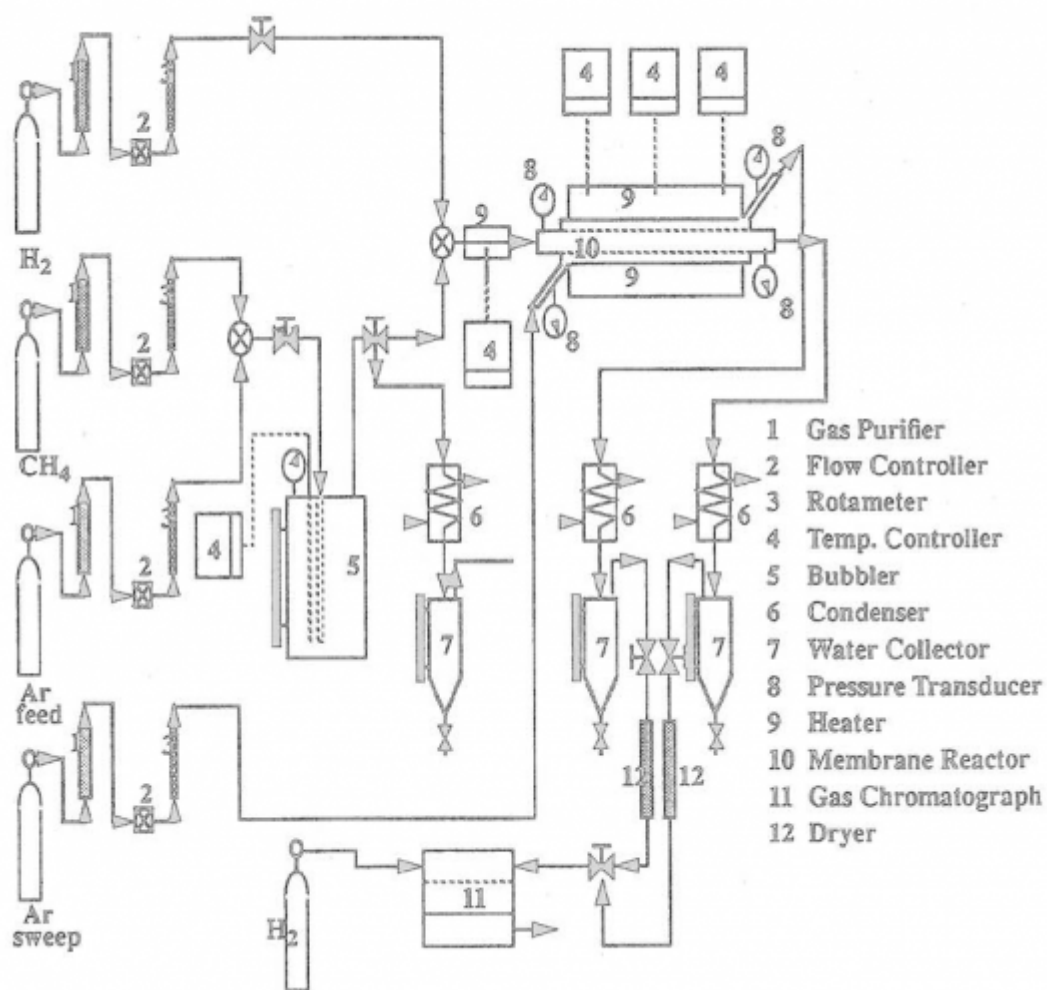


Figure 1:



1234

Figure 2: Fig. 1 :Fig. 2 :Fig. 3 :Fig. 4 :



5678

Figure 3: Fig. 5 :Fig. 6 :Fig. 7 :Fig. 8 :

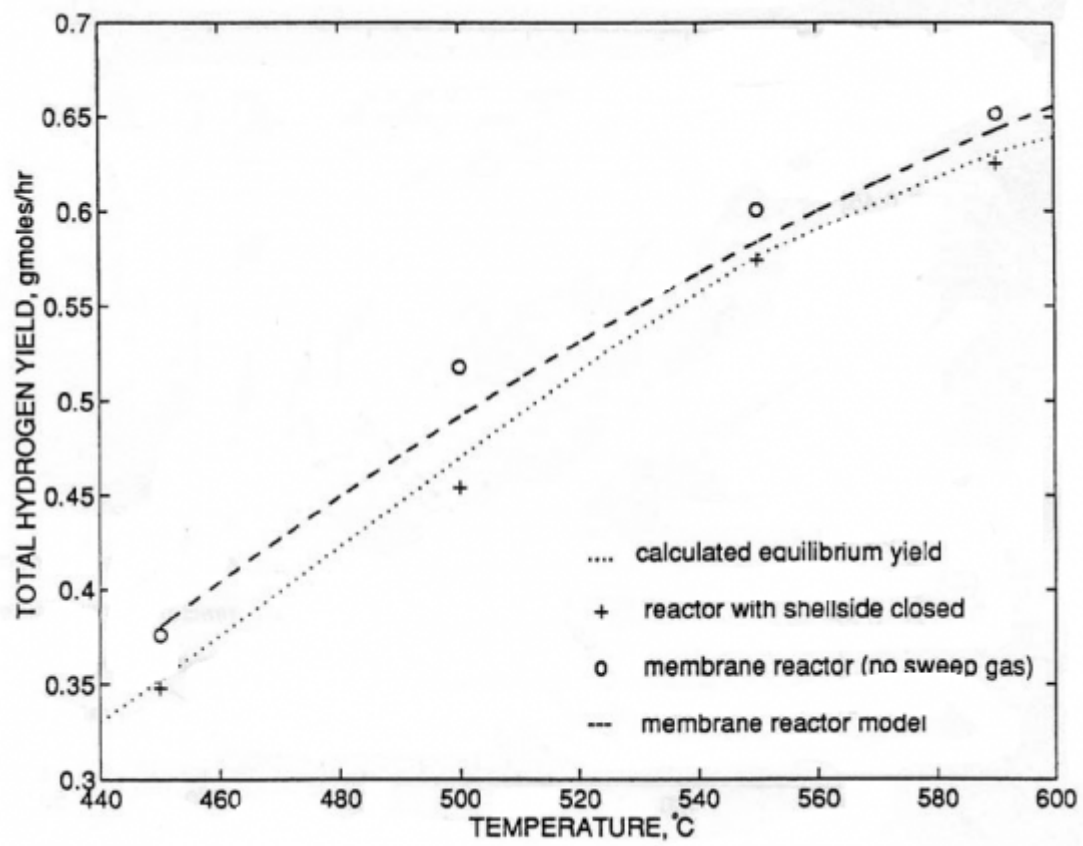


Figure 4:

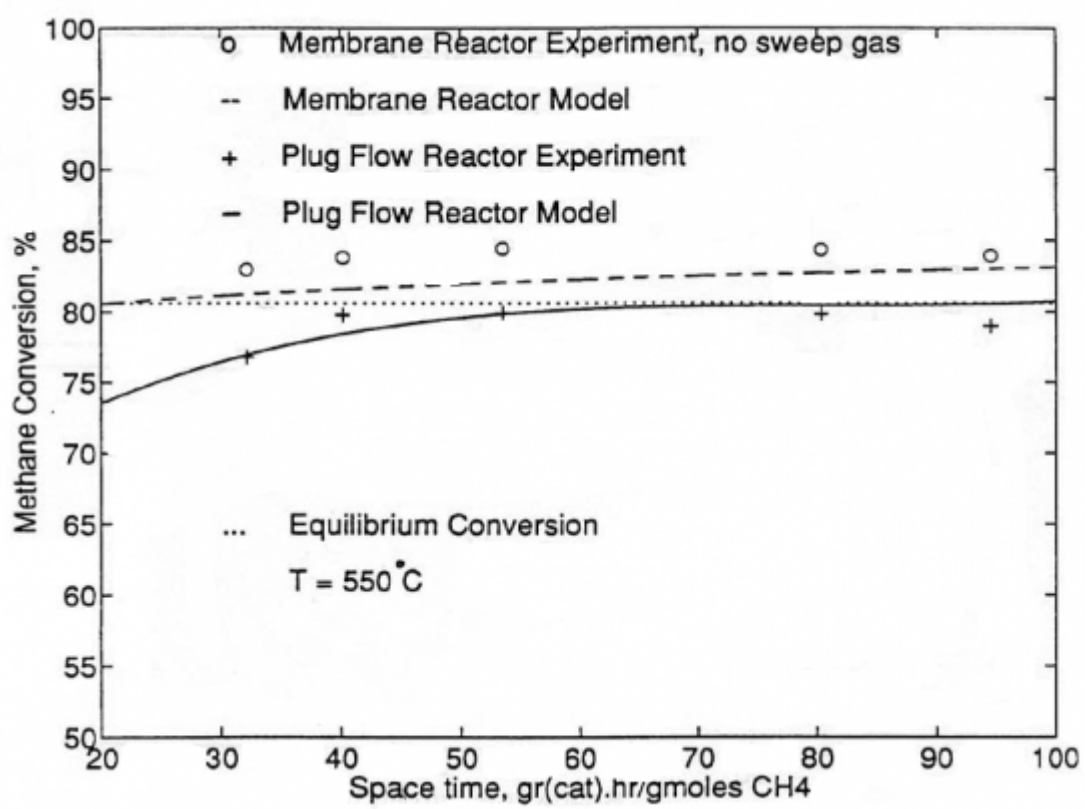


Figure 5:

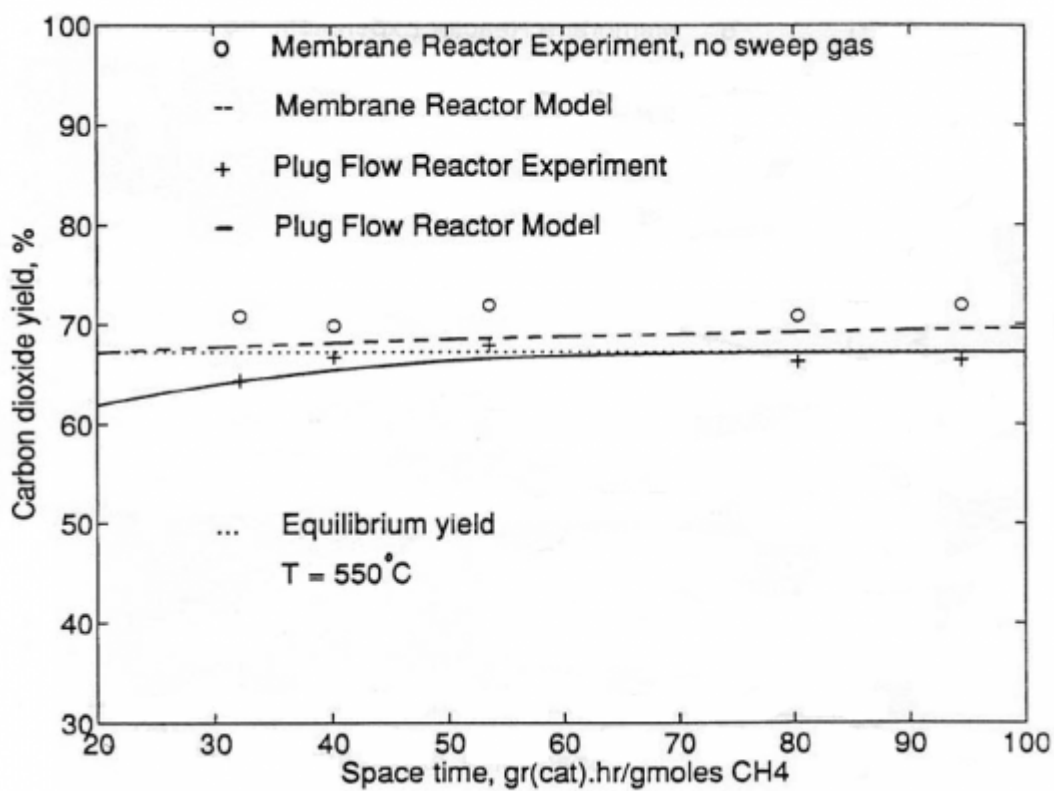


Figure 6:

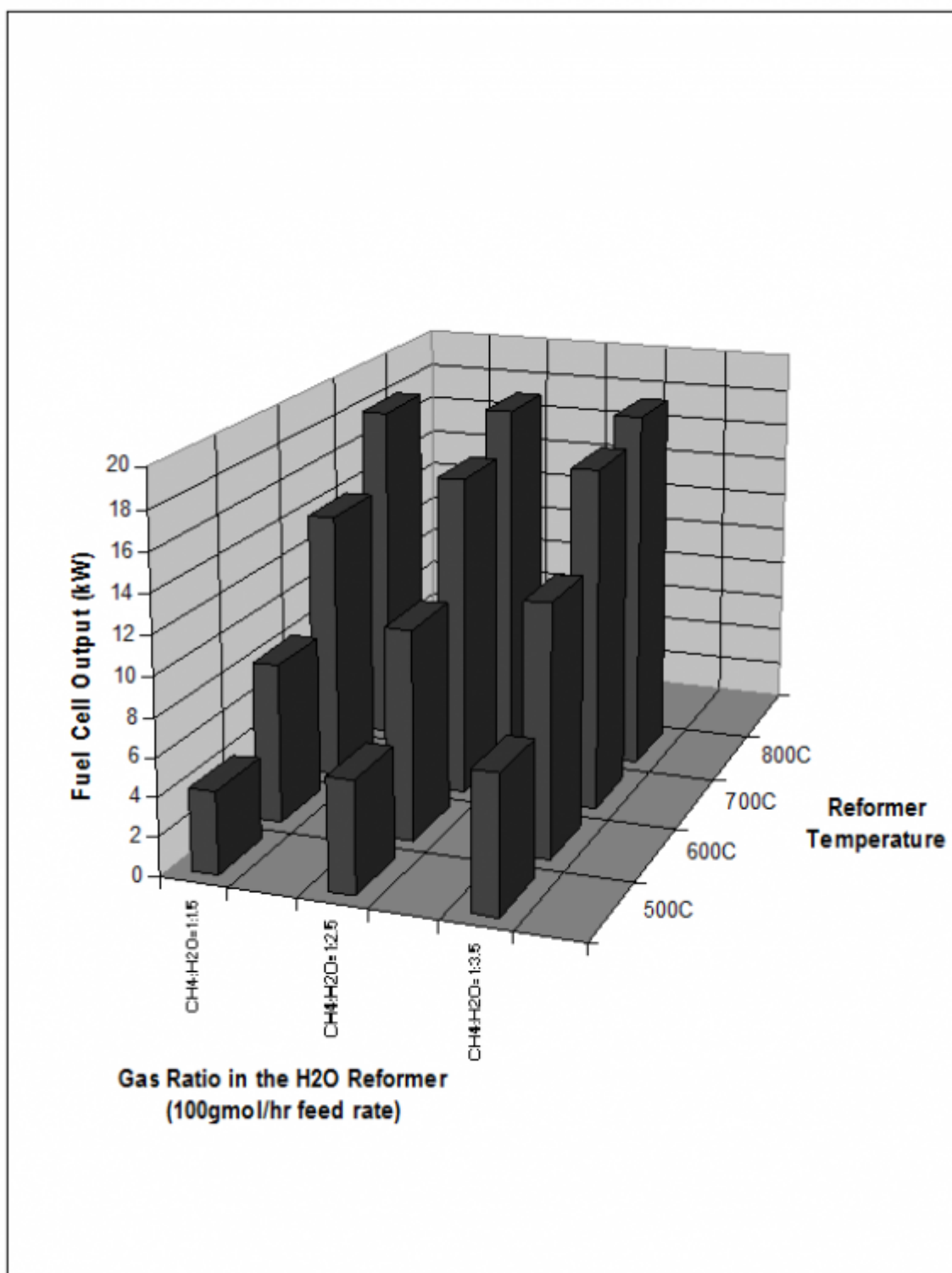


Figure 7:

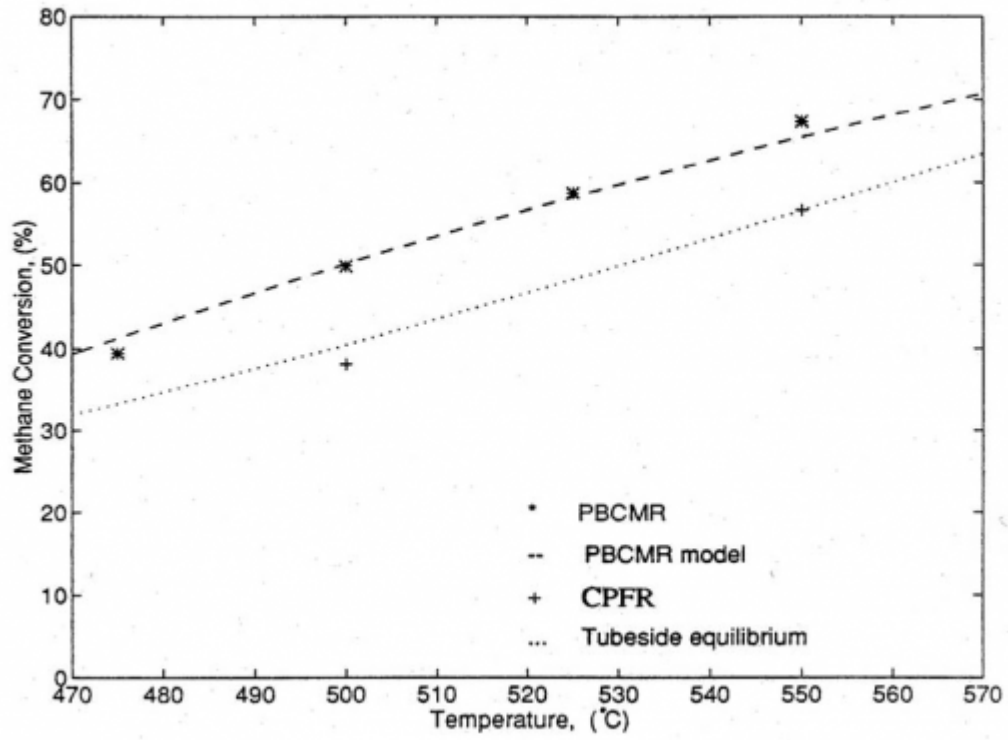


Figure 8:

Cooling	19%
Electricity	43%
Heat	36%
Electric Power availability	2%

Figure 9:



- 
- 224 [Van Hook ()] , J P Van Hook . *Catal. Rev. Sci. Eng* 1980. 21 p. 1.
- 225 [Xu and Froment ()] , J Xu , G F Froment . *AIChE Journal* 1989. 35 p. .
- 226 [Rautenbach and Welsch ()] , R Rautenbach , K Welsch . *J. Membrane Science* 1994. 87 p. 107.
- 227 [Ziaka and Vasileiadis ()] , Z Ziaka , S Vasileiadis . 2000. USPatent #6,090. p. 312.
- 228 [Vasileiadou ()] *Biogas processes and applications*, E M Vasileiadou . 2011. Thessaloniki. (Independent study)
- 229 [Vasileiadis and Ziaka ()] ‘Catalytic reactor configurations for hydrogen generation and inline fuel cell operation’.
- 230 S Vasileiadis , Z Ziaka . *Proc.: Advances in Hydrogen Energy*, (Advances in Hydrogen EnergyBook;
- 231 Indianapolis, USA) 2002. Xlibris Publishing Co.
- 232 [Ziaka and Vasileiadis (2002)] ‘Catalytic reformingshift processors for hydrogen generation and continuous fuel
- 233 cell operation’. Z Ziaka , S Vasileiadis . *Proc. IASTED-Power and Energy Systems*, (IASTED-Power and
- 234 Energy SystemsMarina Del Ray, CA) May 2002. p. .
- 235 [Vasileiadis and Ziaka ()] ‘Efficient catalytic reactors-processors for fuel cells and synthesis applications’. S
- 236 Vasileiadis , Z Ziaka . *Proc. 17th International Symposium on Chemical Reaction Engineering*, (17th
- 237 International Symposium on Chemical Reaction EngineeringHong Kong, China) Aug. 25-28, 2002.
- 238 [Sfetsioris ()] *Energy generation and management*, K Sfetsioris . Availableat:[www.chemeng.ntua.gr/](http://www.chemeng.ntua.gr/courses/bpy/files/sfetsioris.pdf)
- 239 [courses/bpy/files/sfetsioris.pdf](http://www.chemeng.ntua.gr/courses/bpy/files/sfetsioris.pdf) 2010.
- 240 [Vasileiadis and Ziaka (2011)] ‘Methane and methanol steam reforming in a membrane reactor for efficient
- 241 hydrogen production and continuous fuel cell operation’. S Vasileiadis , Z Ziaka . *1st International Symposium*
- 242 *on Intermetallic Compounds in Methanol Steam Reforming*, (Max Plank Institute; Berlin, Germany) Sept.
- 243 2011.