

Three Dimensional Discrete Wavelet Transform Based Robust Multiple Watermarking Algorithm for Spectral Images

Dr. S.Maheswari¹ and K.Rameshwaran²

¹ Kongu Engineering College

Received: 27 October 2011 Accepted: 22 November 2011 Published: 6 December 2011

Abstract

Three Dimensional (3-D) imaging is a fast growing technology in the areas of computer graphics, robotics, metrology, medicine and cultural heritage etc. With the development of internet, 3-D contents are easily manipulated, transmitted and widely distributed. Watermarking has been proved to be an efficient technology in copyright protection of multimedia information. In this paper, a novel blind multiple watermarking algorithm for copyright protection of spectral images is presented. Watermarking is based on 3-D Discrete Wavelet Transform (DWT). Dual binary watermarks are proposed to embed in the mid frequency bands of cover image. One level 3-D DWT is applied to the original spectral image and one level 2-D DWT is applied on two binary watermarks. Eigen values of selected subbands of spectral image are modified by the eigen values of selected subbands of two binary watermarks. Inverse SVD (Singular Value Decomposition) and Inverse 3-D DWT is taken on the modified subbands to obtain the watermarked image. During extraction process, two binary watermarks are recovered from the test image with the help of a secret key. An experimental result shows that, the proposed algorithm produces very high imperceptibility and robustness against various types of attacks like low pass filtering, median Filtering, JPEG compression, histogram equalization, cropping, various angles of rotation and addition of noise like Gaussian, Salt Pepper, Speckle, Poisson etc.

Index terms— DWT, 3-D DWT, SVD and Multiple Watermarking.

1 INTRODUCTION

igital watermarking and steganography techniques are used to address digital rights management, protect information, and conceal secrets. During the last decade, 3-D meshes have been widely used in industrial, medical and entertainment applications. Since 3-D watermarking has also become an active research topic to protect 3-D information, we present a new frame work for copyright protection of 3-D spectral images in this paper. Spectral imaging is a practical tool for various applications like medical imaging, industrial quality control, digital commerce and maintenance of cultural heritage in digital museums etc [1]. In spectral color imaging, color of an object can be Author ? : Kongu Engineering College, Perundurai, Erode-638052, Tamil Nadu, India. (E-mail : maheswari_bsb@yahoo.com).

Author ? : MAM Group of Institutions, Triuchirapalli-620009, Tamil Nadu, India. (E-mail : krameshwaran@gmail.com).

represented more accurately as compared to traditional three channel RGB images.

Three conflicting requirements of watermarking systems are robustness, imperceptibility and capacity [2]. Any watermarking system should allow embedding large number of secret information. Embedding of secret message should not degrade the quality of image; it should withstand in the image; for all kinds of attacks like JPEG compression, low pass filtering, median filtering, noise addition, histogram equalization, rotation, scaling,

cropping etc. Embedding of multiple watermarks enhances the robustness property. Embedding of multiple watermarks, instead of a single one into one cover image improves the robustness of watermarking scheme [3].

Transform domain technique offers very high robustness as compared to spatial domain technique; but it needs more computational complexity because input images are converted into transform coefficients by using various image transforms like DCT [4][5], DFT and DWT [6][7][8][9] etc. 3-D watermarking techniques are classified into two types [10], similar to that of 2-D watermarking, spatial domain technique [10] and spectral domain technique [4][5][6][7][8][9]. Spatial domain techniques are further classified into two types. They are Geometry modification technique and Topology modification technique. In spectral method; information can be embedded in one of the mesh transform domains like mesh spectral decomposition, wavelet transform or spherical transform.

The use of wavelets in image and video coding has increased significantly over the years, mainly due to the superior energy compaction property of wavelets compared with the traditional transforms like DCT [11]. In this paper, we have proposed a method to embed the watermark in wavelet transform domain. The 3-D object is processed for obtaining 2-D slices, so that each 3-D objects are represented by a set of 2-D slices. A 3-D DWT domain, obtained by performing a 2-D spatial wavelet transform and then a temporal 1-D wavelet transform [12]. The Haar Wavelet Transform consistently outperforms the more complex ones when using noncoloured watermark [13]. Therefore, we propose 3-D Haar Wavelet Transform based watermarking scheme. Eigen values of mid frequency subbands of a cover image and two binary watermarks are obtained by

2 (I)

Singular Value Decomposition (SVD) [1,8]. Eigen values of mid frequency subbands are modified by the Eigen values of dual binary watermarks. Section (2) deals with 3-D DWT. Section (3) discusses about the proposed embedding and extraction algorithm, Section (4) gives the experimental results of proposed scheme, followed by conclusion in section (5).

3 II. THREE DIMENSIONAL DWT

4 PROPOSED METHOD

In recent years, several 3-D watermarking techniques have been proposed for gray scale and colour images for authentication, copyright protection, finger printing and ownership assertion. Here, we propose a novel blind watermarking scheme based on wavelet transform for spectral images. Designing of blind watermarking i.e. extracting the watermark without original image and original watermark is a very difficult task [9]. In this paper, blind watermarking scheme has been employed. Watermark is extracted with the help of a secret key. Mid frequency bands are selected to embed the secret message in order to compromise between imperceptibility and robustness. Watermark embedding and extraction processes are explained in the following sections.). Normalised Correlation of recovered watermark is calculated on comparing with original watermark. Watermark extraction scheme has been shown in Figure 5.

5 IV. EXPERIMENTAL RESULTS

The experiments were performed on two different hyperspectral natural images [14]. Natural image of the size 256x256x30 and two binary watermarks of size 32x32 were taken to evaluate the proposed algorithm. PSNR value of the watermarked image is calculated by using the equations (??) and (2).

$$(1)$$

(2) where m, n, and l are dimensions of the image and are the pixel values of the original and watermarked image. Normalized Correlation (NC) between original watermark and extracted watermark from the test image is calculated by using the equation (??).

(3) PSNR value of the watermarked image and Normalised Correlation of recovered watermark are shown in Table ??.

Table ??: PSNR Value of Watermarked Image and NC Any watermarking system should be robust against various image processing attacks. It should not be removable by unauthorized users and it should not degrade the quality of the images. There are many attacks against which image watermarking system could be judged. The attacks include JPEG compression, Histogram equalization, various filtering operations like, average filtering, median filtering, addition of noise like Salt and Pepper noise, Gaussian noise, speckle noise and Poisson noise, cropping, various angles of rotation and so on. These attacks are applied to the watermarked images to evaluate recovery process. Table 2, 3 and 4 shows the PSNR value and NC under various attacks. Table 5 shows the extracted watermark image under various attacks from Natural Image I. The proposed watermarking scheme is compared with existing recently published papers by Arto Kaarna et al [15], Long Mal et [16], the results are shown in Tables 6 and 7.

6 CONCLUSION

Three Dimensional mesh watermarking is an interesting and promising research area. In this paper, a novel blind multiple watermarking algorithm based on 3-D DWT for copyright protection of spectral images has been proposed. Dual binary watermarks have been proposed to embed in mid frequency bands to increase the

100 robustness against attacks and to improve imperceptibility. Extracting the secret message without the help of
 101 original image and original watermark is a very difficult task. We extracted dual binary watermarks with the help
 102 of details of subband selection and strength factor only. Experimental result shows that the proposed scheme
 103 achieves very high imperceptibility and robustness against various image processing attacks like LPF, Median
 104 Filtering, JPEG Compression, histogram equalization, cropping, various angle of rotation and addition of noise
 like Gaussian, Salt & Pepper, Speckle, Poisson etc. ^{1 2 3 4 5}



3

Figure 1: A 3 -

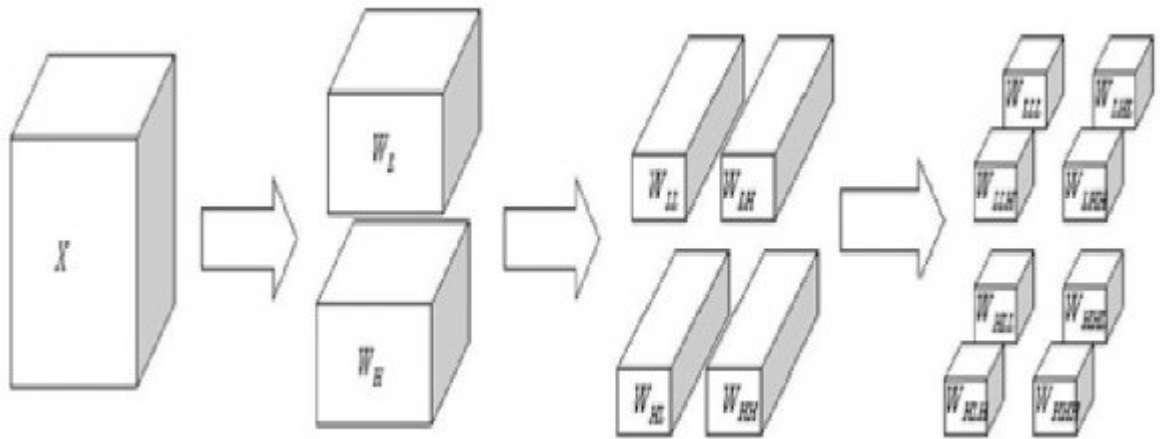

133134

Figure 2: Fig. 1 : 3 . 3 . 1 / 3 : 4 :

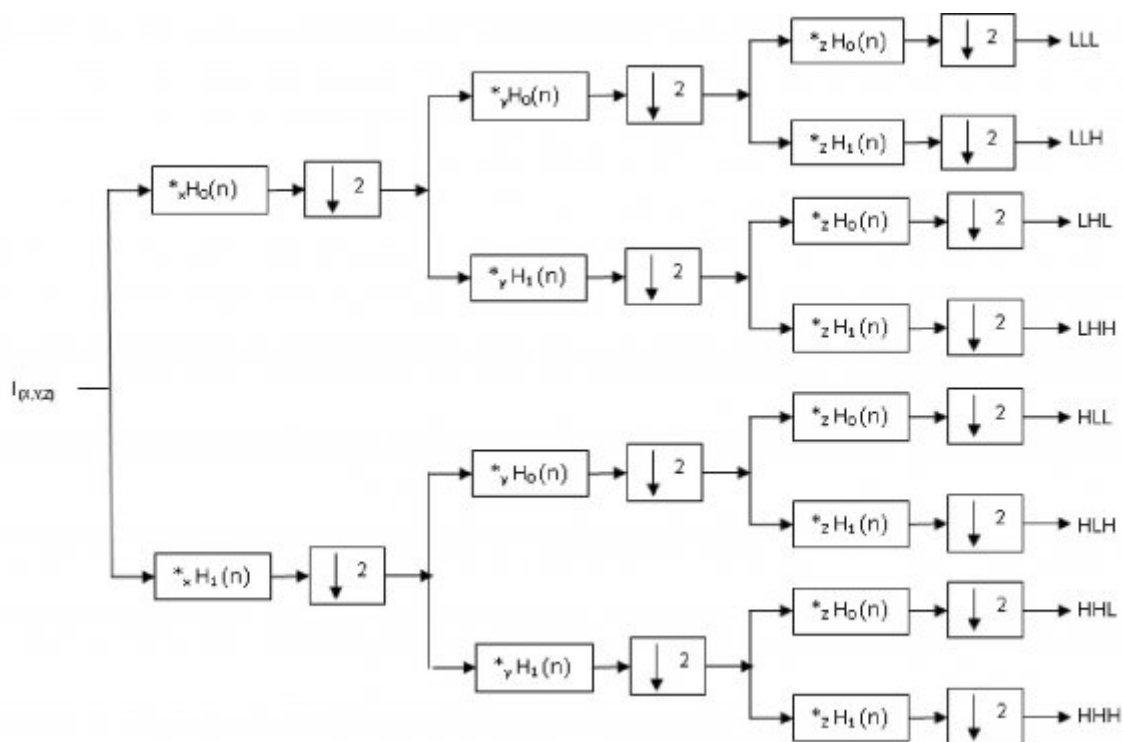

3

Figure 3: Figures 2 and 3

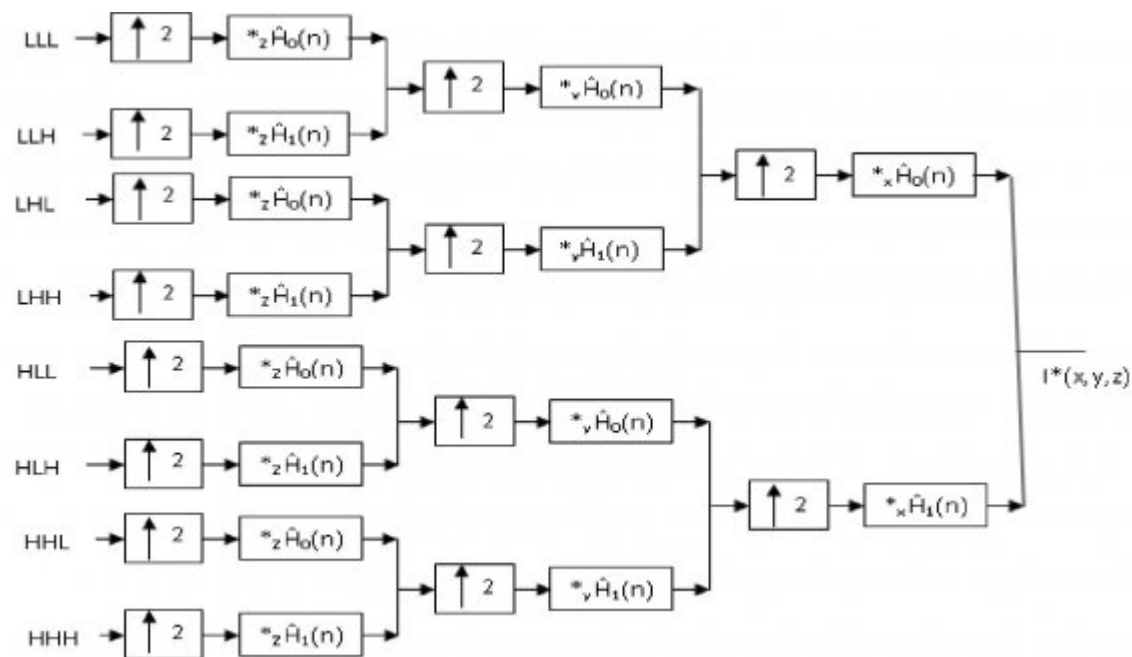

23

Figure 4: Fig. 2 :Fig. 3 :

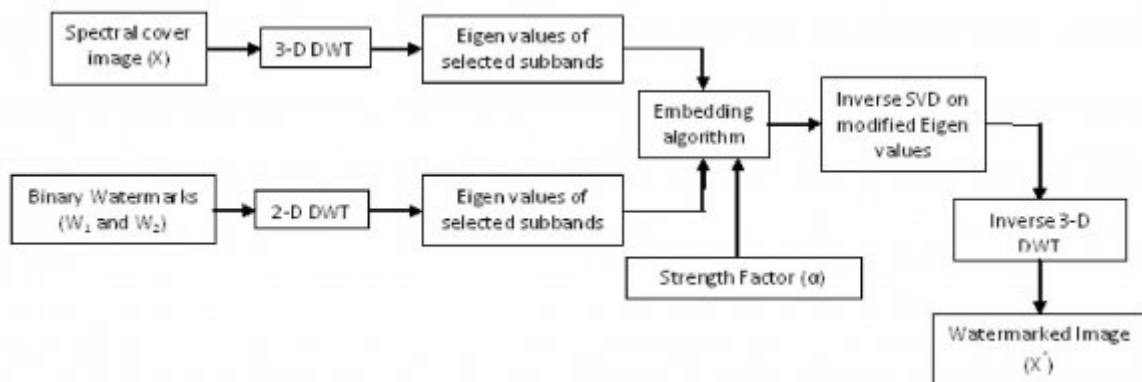

5

Figure 5: Fig. 5 :

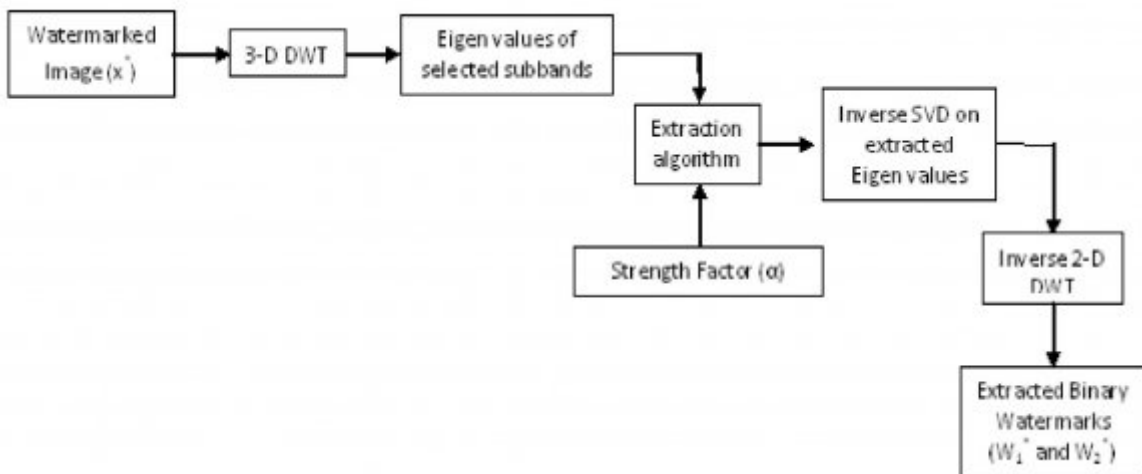

6

Figure 6: Figure 6 :

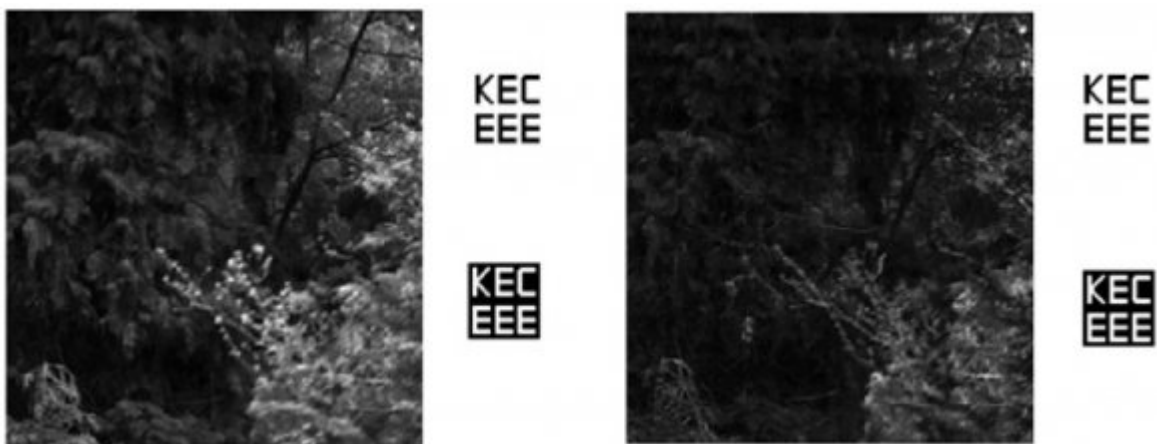

Figure 7:

6 CONCLUSION

2

	PSNR Value in dB	Normalised correlation W 1	* W 2 *
Natural Image I	69.7494	1	1
Natural Image II	57.7162	1	1

Figure 8: Table 2 :

3

[Note: 1) under various Attacks.]

Figure 9: Table 3 :

4

I)
Global

[Note: 2) under various Attacks.]

Figure 10: Table 4 :

5

© 201

Figure 11: Table 5 :

6

Methods	PSNR in dB
Arto Kaarna et al	38.95
Long Mal et al	48.74
Proposed method	69.74

Figure 12: Table 6 :

7

LPF	Arto Kaarna et al	Long Mal et al	Proposed method W 1	W 2
3 * 3	0.66	0.73 0.9582	0.9576	
5 * 5	0.43	0.56 0.9473	0.9477	
7 * 7	0.30	0.43 0.9429	0.9429	

Figure 13: Table 7 :

¹December

²© 2011 Global Journals Inc. (US)

³December Three Dimensional Discrete Wavelet Transform Based Robust Multiple Watermarking Algorithm for Spectral Images

⁴Global I) 2011 December (Three Dimensional Discrete Wavelet Transform Based Robust Multiple Watermarking Algorithm for Spectral Images

⁵(I) 2011 December Three Dimensional Discrete Wavelet Transform Based Robust Multiple Watermarking Algorithm for Spectral Images

-
- 105 [Wang and Zhang (2010)] ‘A Blind Video Watermark Detection Method Based on 3D-DWT Transform’. Ce
106 Wang , Chao Zhang , Pengweihao . *Proc.of IEEE 17 th International Conference on Image Processing*, (.of
107 IEEE 17 th International Conference on Image essingHong Kong) September, 2010. p. .
- 108 [Dumitru Dan Burdescu and Stanescu ()] ‘A New 3d Watermarking Algorithm’. Liana Dumitru Dan Burdescu ,
109 Stanescu . *Proc.of IEEE*, (.of IEEE) 2009. May 2008. p. 381. (Anca Ion and RazvanTanasie)
- 110 [Saoussen and Jabra (2008)] ‘A New Approach of 3D Watermarking Based on Image Segmentation’. Ben
111 Saoussen , Ezzeddinezagrouba Jabra . *Proc. of IEEE symposium on Computers and Communications*, (of
112 IEEE symposium on Computers and Communications) July 2008. p. .
- 113 [Bhatnagar and Raman (2009)] ‘A new robust reference watermarking scheme based DWT-SVD’. Gaurav
114 Bhatnagar , Balasubramanian Raman . *Computer Standards and Interfaces* September 2009. 31 (5) p. .
- 115 [Hongmeiliee and Hwang (2003)] ‘A Robust 3D Wavelet Video Watermarking’. Nuoechen Hongmeiliee , Hwang
116 . *IEEE Trans. on Image Processing* October 2003. 32 p. .
- 117 [Mallat ()] *A Wavelet Tour of Signal Processing*, S Mallat . 1999. New York: Academic Press.
- 118 [Ma et al. ()] ‘ChirawatTemi, SomsakChoomchuay, and AttasitLasakul ”A Robust Image Watermarking Using
119 Multiresolution Analysis of Wavelet’. Long Ma , Changjun Li , Shuni Song . *Proceedings ofInternational
120 Conference on Communications, Circuits and Systems*, (International Conference on Communications,
121 Circuits and Systems) 2006. June 2. 2005. 2 p. . (Proc.of International symposium on communication and
122 information technologies)
- 123 [Kaarna and Toivanen ()] ‘Digital watermarking of spectral images in PCA/Wavelet-transform domain’. Arto
124 Kaarna , Pekka Toivanen . *proc. of IEEE symposium on Geoscience and Rem ote Sensing*, (of IEEE symposium
125 on Geoscience and Rem ote Sensing) 2003. 6 p. .
- 126 [Ma et al.] *Digital watermarking of spectral images using SVD in PCAtransform domain*, Long Ma , Changjun
127 Li , Shuni Song . (proc. of IEEE International)
- 128 [S ()] ‘Discrete Wavelet Transform Based Multiple Watermarking Scheme’. S . *proc. IEEE Conference on
129 Convergent Technologies for Asia-Pacific Region*, (IEEE Conference on Convergent Technologies for Asia-
130 Pacific Region) 2003. 3 p. .
- 131 [Fu ()] ‘Robust image watermarking scheme based on 3D-DCT’. Yonggang Fu . *Proc. of Sixth International
132 Conference on Fuzzy Systems and Knowledge Discovery*, (of Sixth International Conference on Fuzzy Systems
133 and Knowledge Discovery) 2009. p. .
- 134 [Yang et al. (2006)] ‘Robust Watermarking for Video Based on Quasi-3D DWT/DCT’. Xiaoyuan Yang , Yijie
135 Keniu , Wei Wu , Zhang . *Proc. of The IET International Conference on Wireless Mobile and Multimedia
136 Networks (ICWMMN 2006)*, (of The IET International Conference on Wireless Mobile and Multimedia
137 Networks (ICWMMN 2006)Hangzhou, China) November 2006. p. .
- 138 [Nascimento et al. ()] ‘Statistics of spatial cone-excitation ratios in natural scenes’. S M C Nascimento , F Ferreira
139 , D H Foster . *Journal of the Optical Society of America A* 2002. 19 p. .
- 140 [Brannock et al. (2009)] ‘The Effect of Wavelet Families on Watermarking’. Evelyn Brannock , Michael Weeks ,
141 Robert Harrison . *Journal of Computers* June 2009. 4 (6) p. .