

# 1 Design and Manufacturing of an Array an Singl Microstrip Patch 2 Antenna to Transmit and Receive by using Same Patch Shape

3 Ahmed Jameel Abdulqader<sup>1</sup>

4 <sup>1</sup> University of Ninevah

5 *Received: 9 December 2017 Accepted: 5 January 2018 Published: 15 January 2018*

---

## 7 Abstract

8 In the last years, the progress in communication systems requires the development of high  
9 gain and low-cost Microstrip array antennas with suitable feeding technique and a dielectric  
10 substrate for applications in 2.1 GHz. The array antenna and single antenna were constructed  
11 on a substrate FR4 with a relative permittivity of 4.3. The suggested single antenna is  
12 benefited of a compact size of 50×30 mm<sup>2</sup> at 2.1GHz frequency band and the suggested  
13 dimension array antenna is 160\*52 mm<sup>2</sup>. The antenna is Microstrip line feeder and is  
14 simulated on CST software. Performance parameter evaluated are increased by using  
15 reflection, the array design has directivity up to 8.955 dBi and Gain up to 8.506 dB with  
16 satisfactory radiation characteristics. The single design has directivity up to 2.352 dBi and  
17 Gain up to 2.206 dB with satisfactory radiation characteristics. Been fabricated the array and  
18 single Microstrip antenna using CNC Machine. The practical results of radiation patterns and  
19 gain for two cases (array and single) are approximately similar to theoretical results. The  
20 computer simulation results show that the antenna having good impedance bandwidth ( $S_{11} <$   
21  $-10$  dB) at the resonant frequency.

---

23 **Index terms**— microstrip array antenna, single microstrip antenna, patch shape, 3g applications.

24 Introduction odern wireless communication system requires simple structure, lightweight, low profile, and  
25 high gain antennas to assure high efficiency, mobility, and reliability characteristics. Microstrip antenna satisfies  
26 such requirements. This antenna provides all of the advantages of printed circuit technology. These features  
27 of Microstrip antennas create them public in many wireless communication applications such as radar, satellite  
28 communication, medical applications, etc. [1]. The restrictions of Microstrip antennas are narrow frequency band  
29 and disability to operate at high power levels of a coaxial line, waveguide or even strip line.

30 Therefore, the defy in Microstrip antenna design is to increase the bandwidth and gain [2]. Different array  
31 configurations of Microstrip antenna can give high gain, wide bandwidth and improved efficiency. The distribution  
32 of voltages through the elements of an array depends on feeding network. Suitable feeding network cumulate all  
33 of the induced voltages to feed into one point [3]. The proper impedance matching over the series and corporate  
34 feeding array configurations supplies high efficiency Microstrip antenna. Power distribution through antenna  
35 elements can be modified by corporate feed network. The corporate feed network can lead beam by introducing  
36 phase change [2].

37 In the array antennas, elements can be fed by a single line or by several lines in a feed network configuration.  
38 Based on their feeding methods, arrays are classified as Series feed network and T-shaped corporate feed network.  
39 Series-feed Microstrip array is molded by intersecting all the elements with high impedance transmission line and  
40 feeding the power at the first element. Because the feed arrangement is compact the line losses related to this  
41 type of array are lower than those of the corporate-feed type [2]. Seriesfed arrays can be conveniently fabricated  
42 using photolithography for both the radiating elements and the feed network. However, this technique is limited  
43 to arrays with a fixed beam or those which are scanned by varying the frequency, but it can be applied to linear

and planar arrays with single or dual polarization. Also, any changes in one of the elements or feed lines affect the performance of the others. Therefore in a design, it is important to be able to take in to account these and other effects, such as mutual coupling, and internal reflections. Those who have been designing and experiment arrays antennas mention that radiation from the feed line, using either series or corporate-feed network, is an earnest problem that limits the crosspolarization and sidelobe level of the arrays. Both cross polarization and sidelobe levels can be improved by isolating the feed network from the radiating face of the array. This can be accomplished using either probe feeds or aperture coupling. The main limitation in seriesfeed arrays is the big variation of the impedance and beam-pointing direction over a band of frequencies [2]. M II.

## 1 Arrays And Feed Networks

Performance of antenna arrays depends on our ability to feed the array elements with input currents having accurate phase relationships. This can be accomplished by using appropriately designed "feed networks" consisting of transmission line (TL) segments. We continue our study of antenna arrays with examples illustrating feed network design issues. The Microstrip antenna can be agitated either by a Microstrip line or coaxial probe. It can also be excited indirectly using electromagnetic coupling or aperture coupling and a coplanar waveguide feed, in which case there is no direct metallic contact between the feed line and the patch [4]. Feeding technique effective the input impedance and characteristics of an antenna and is an influential parameter. Elements of an array can be fed by a single line, known as a series-feed network, or by multiple lines, known as a corporate-feed network, shown in Fig 1. III.

## 2 Corporate Feed Network

This Network gives more control of the feed of each element (amplitude and phase) and they are perfect for multi-beam arrays or formed-beam arrays. The amplitude can be changed with an amplifier or an attenuator when the phase can be controlled using a phase shifter. This network is used to supply power division of  $2n$  (i.e.  $n = 2, 4, 6$ , etc.). This idea can be checked by using either tapered lines as shown in Transformers.

This power split can be achieved by using three port power dividers of equal division (3dB) with the use of a T-junction power divider. An ideal power divider is lossless, reciprocal and matched at all ports. A Tjunction power divider is reciprocal and can be considered lossless if the transmission line loss is not taken into account [5]. Helmholtz reciprocity theorem (generalized by Carson) states that "If an emf (electromagnetic force) is applied to the terminals of an antenna A and the current measured at the terminals of another antenna B, then an equal current (in both amplitude and phase) will be obtained at the terminals The following formula is applicable when the transformer is a quarter-wavelength or an odd multiple of a quarter-wavelength for a perfect impedance match:

A quarter-wave transformer with the input impedance of  $Z_C = 50\Omega$  and load impedance of  $Z_L = 100\Omega$  is equal to  $Z_0 = 70.71\Omega$ . These formulas explain the values used in Fig 3 IV.

## 3 Beeds In Transmission Lines

There is no best way to bend a Microstrip or stripline transmission line. The first problem is that the discontinuity changes the line characteristic impedance; without compensation, the bend adds shunt capacitance. But in reality, the small capacitance that is usually a result doesn't change the circuit's performance very much. The other problem associated with bends it can cause far more damage to the intended performance of a highly tuned circuit: the effective length of the transmission line becomes shorter than the centerline length. Show Fig 6. V.

## 4 Quarter-Wave Transform

In the case of mismatch in impedance between two points on a transmission line can be compensated with a  $(\lambda/4)$  quarter-wave transformer [7]. The quarterwave transformer  $(\lambda/4)$  is a very profitable matching technique that also explains the properties of standing waves on a mismatched line. First, an impedancebased illustration of how a quarter-wave transformer works will be qualified; then a more intuitive illustration that is similar to ruinous interference in thin films will be discussed. In a quarter-wave transformer, a load resistance  $R_L$  needs to be matched to the characteristic feed line impedance  $Z_0$  through a short length of transmission line of unknown length  $l$  and impedance. The input impedance  $Z_1$  looking into the matching section of line is given by: In the case of an ideal transition with no reflections at the interface between Microstrip  $Z_{in} = Z_0$  and load, and this gives us characteristic impedance  $Z_1$  as: which is the geometric mean of the load and source impedances. From this conFig, there will be no standing waves on the feedline although there will be standing waves on the quarter wave transformers  $(\lambda/2)$  matching section. In fact, any odd multiple  $(2n + 1)$  of  $l = \lambda/4$  will also work.

When the line length is precisely  $\lambda/4$  the reflected wave from the load destructively interferes with the wave reflected from  $Z_0$ ,  $Z_1$  the interface and they cancel each other out. It should be noted that this method can only match a real load. If the load has an appreciable imaginary component, it must be matched differently. It can be transformed into a purely real load, at a single frequency, by adding an appropriate length of feedline. Fig ?? shows the complete feed network with the patches. There are many transmission lines, V grooves, power splitters, and quarter wave transformers.

## 5 Gain Measurements

To gain measurements, we use the Friis formula.

By writing the Friis formula as (dB), we obtained:

Where FSL is Free Space Loss.  $P_r$  and  $P_t$  are received and transmitted power respectively.  $G_r$  and  $G_t$  are received and transmitted Gain respectively.  $D$ , the distance between transmitter and receiver,  $\lambda$  is Wavelength. From the measuring the transmitted and received power

## 6 Conclusion

In this research, single and four elements Microstrip patch antenna array by corporate (parallel) feed network at 2.1 GHz application are presented. This suggested array antenna is investigated and successfully simulated in this research; the simulated return loss, radiation pattern and bandwidth showed well performance for the single antenna at 2.1GHz. They investigate higher directivity, gain and better bandwidth with practical technology and theoretical analysis. The results of the array antenna are compared with those of single antenna of novel patch Microstrip antenna. It is found that there is an important change in the radiation features of array antenna. It can be concluded from the top results that, designing a proper feed network and impedance matching are very important parameters in Microstrip patch antenna design (single and array). Selection a proper position for ending the feed line affects the overall performance of the antenna. The simulation results show return loss of -64.45 dB for the array antenna and -36.44 dB for the single antenna.

From the results, it is seen that the suggested array and single antenna achieve good value of directivity, gain performance and the antenna has good bandwidth, this makes the suggested antenna design suitable for use in the 2.1GHz applications as a transmitting and a receiving.

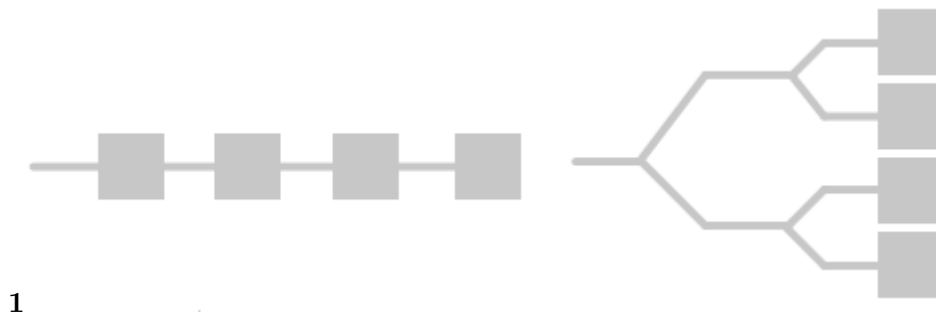

Figure 1: Fig. 1 :

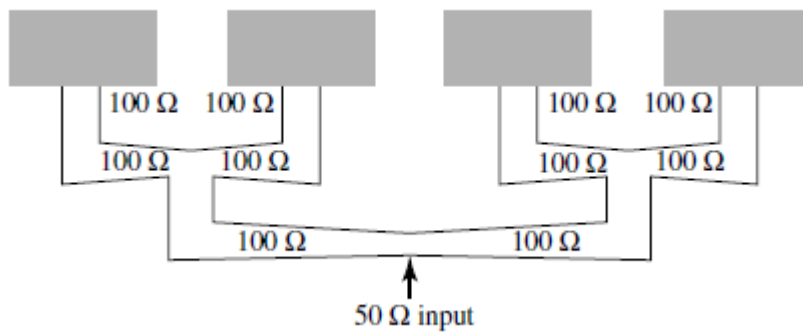
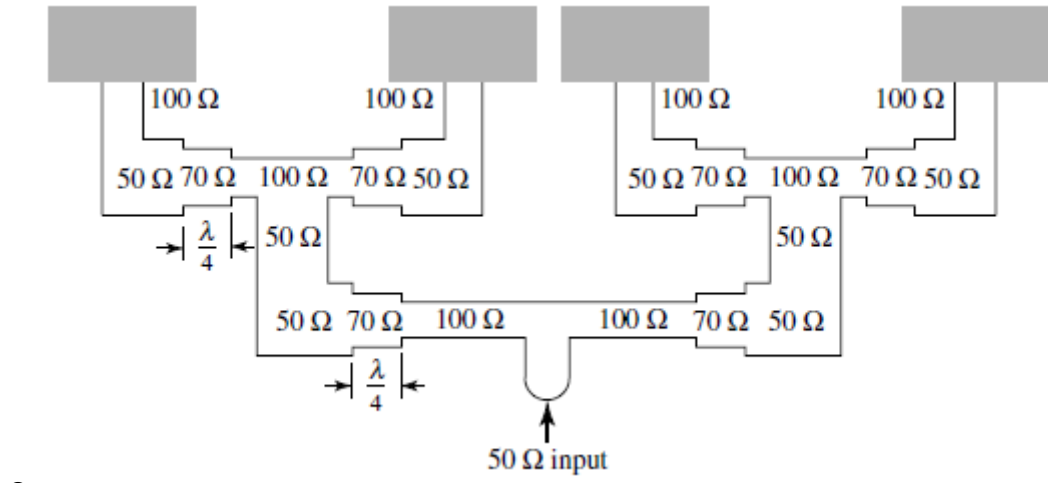

Figure 2:

<sup>1</sup>& © 2018 Global Journals

<sup>2</sup>© 2018 Global Journals



2

Figure 3: Fig. 2 :

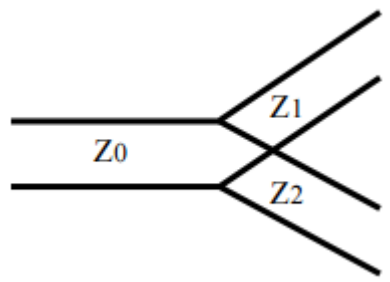

3

Figure 4: Fig. 3 :

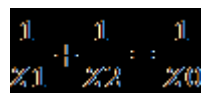
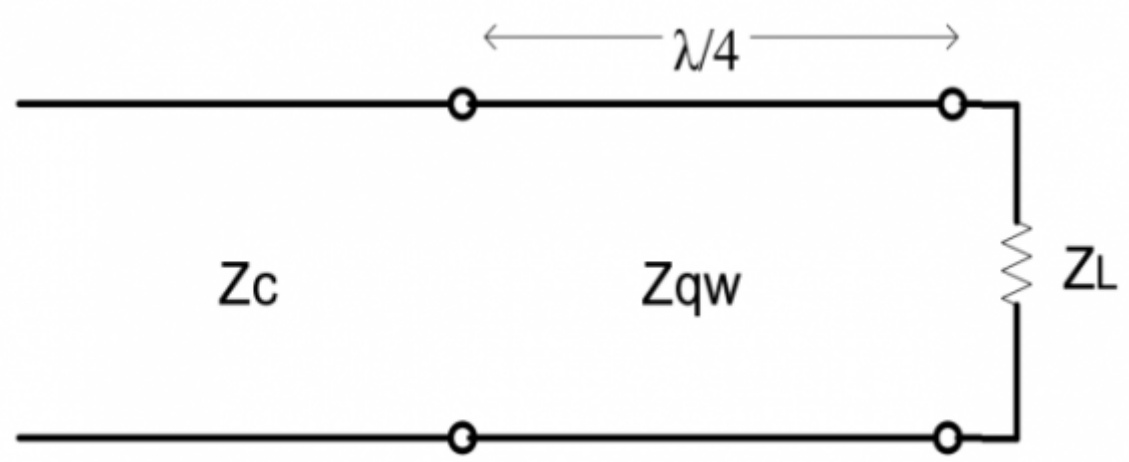

Figure 5: F



4

Figure 6: Fig. 4 :

$$Z_{in} = \sqrt{Z_0 Z_L}$$

5

Figure 7: Fig. 5 :

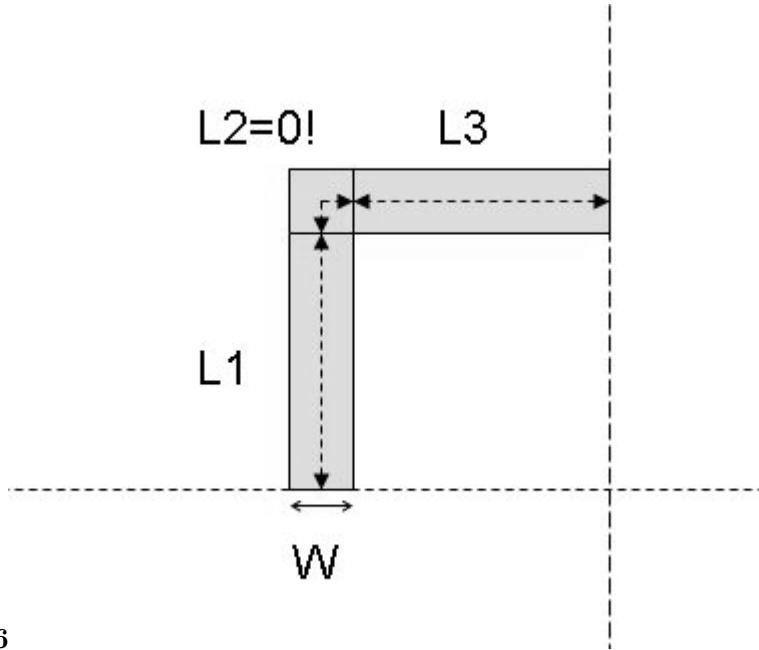

6

Figure 8: Fig. 6 :

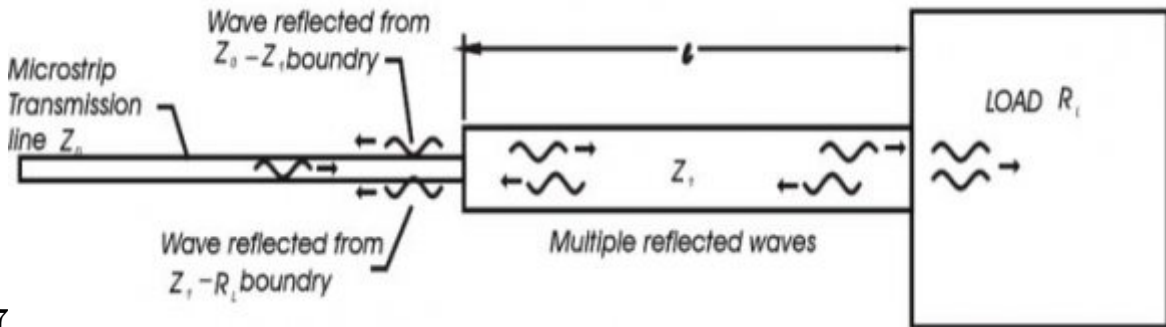

7

Figure 9: FFig. 7 :

$$Z_{in} = Z_0 \frac{Z_L + jZ_0 \tan \beta l}{Z_0 + jZ_L \tan \beta l}$$

89

Figure 10: Fig. 8 :FFig. 9 :

$$Z_1 = \sqrt{Z_0 Z_L}$$

9

Figure 11: Fig. 9 :

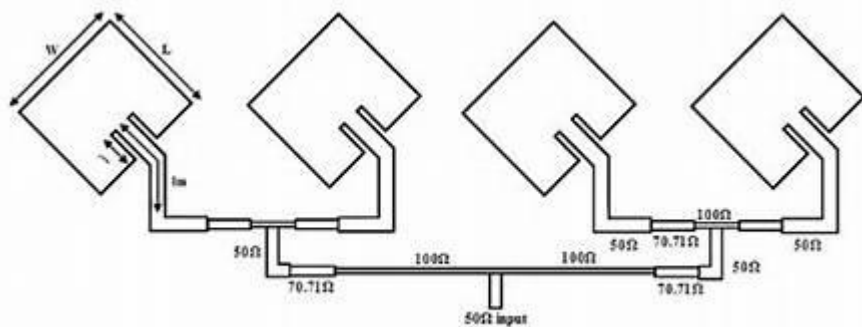

10

Figure 12: Fig 10 (

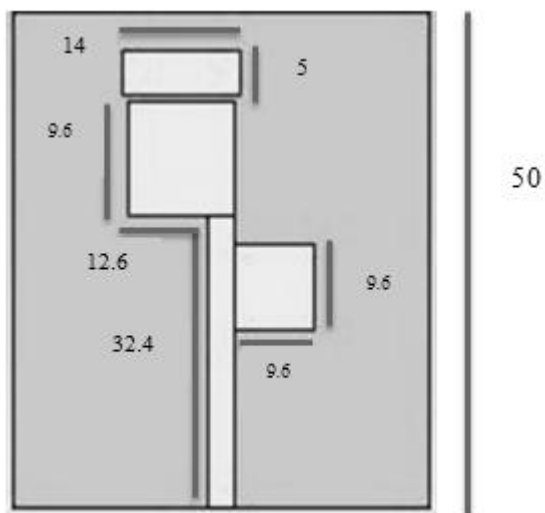

10

Figure 13: Fig. 10 :

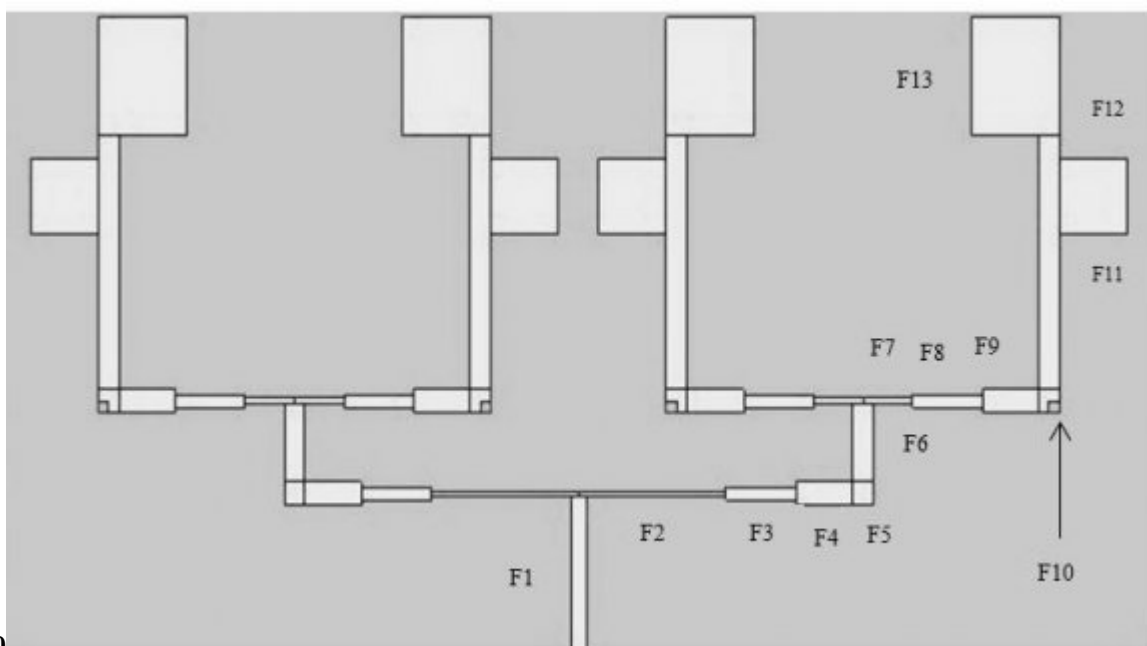

10

Figure 14: Fig. 10 :

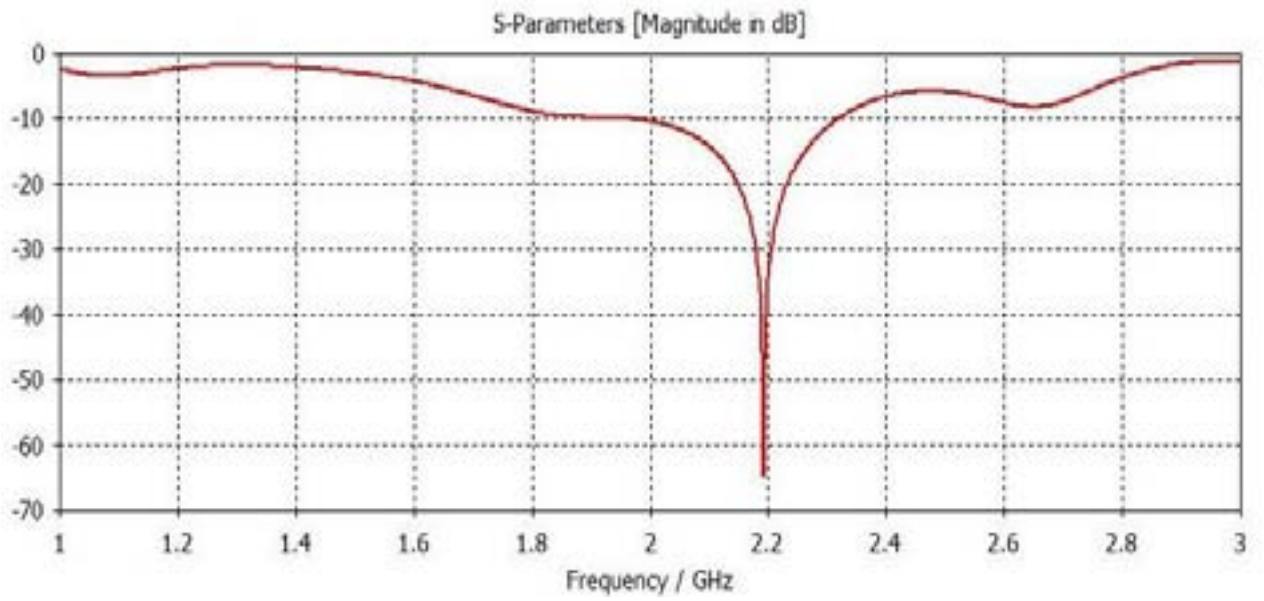

11

Figure 15: Fig. 11 :

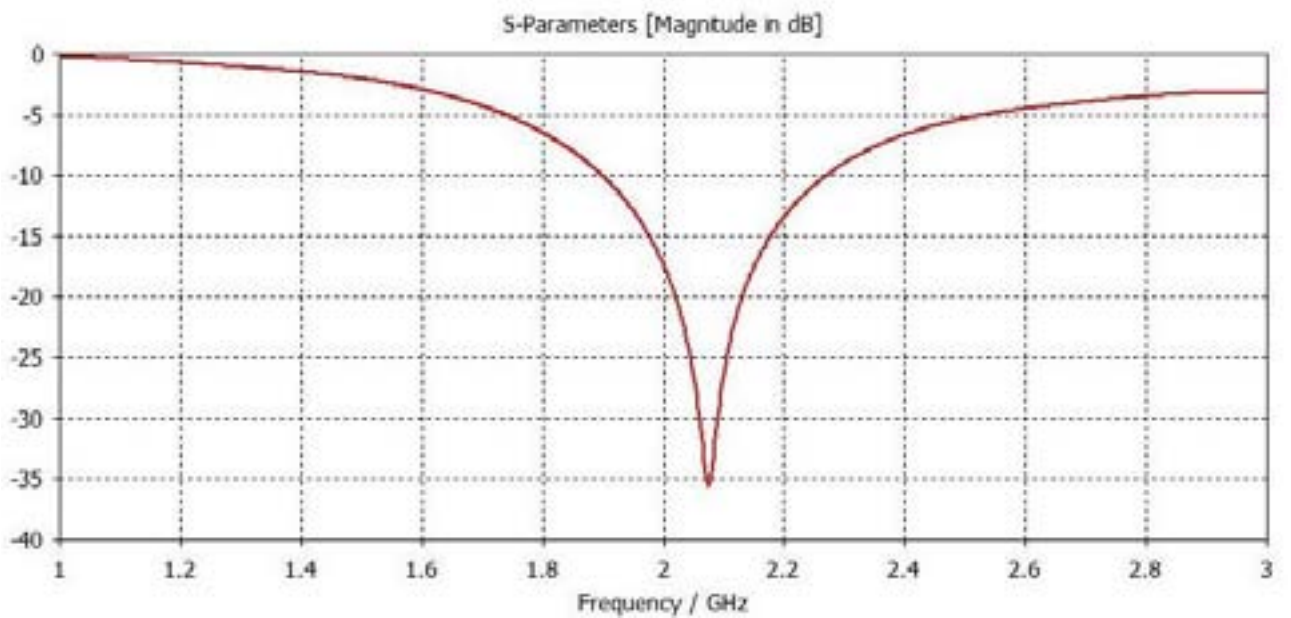

11

Figure 16: Fig. 11 :

## 6 CONCLUSION

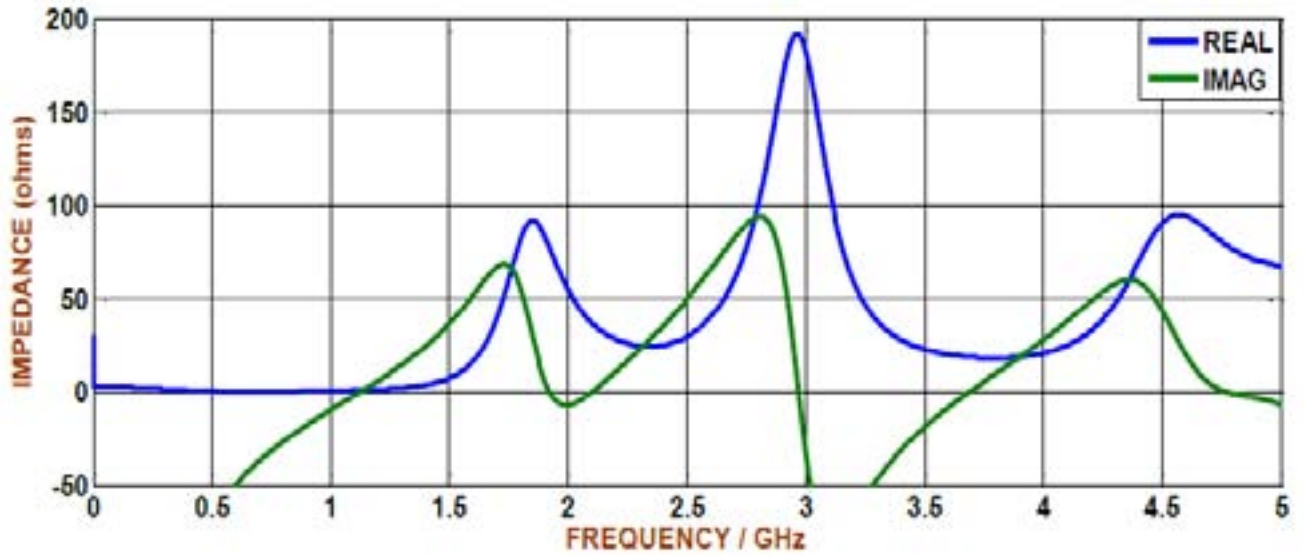
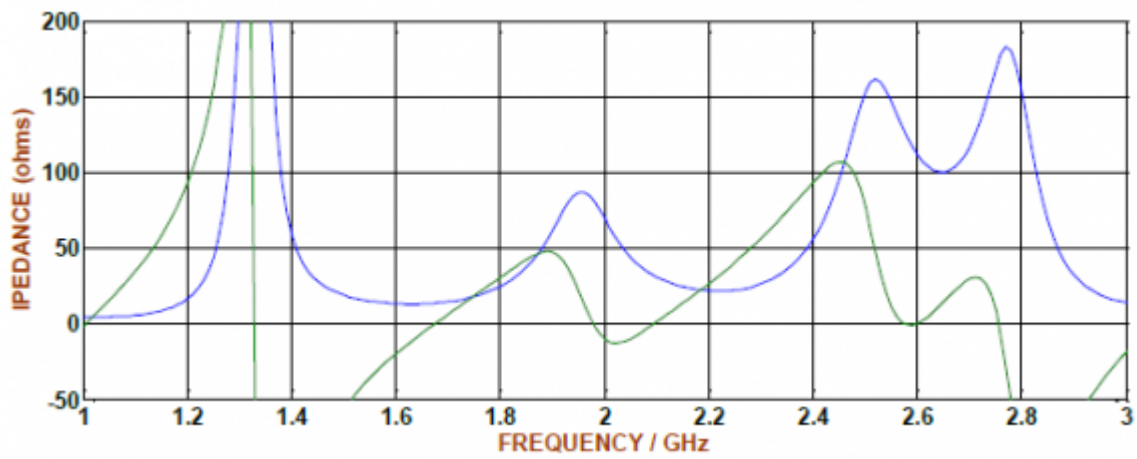
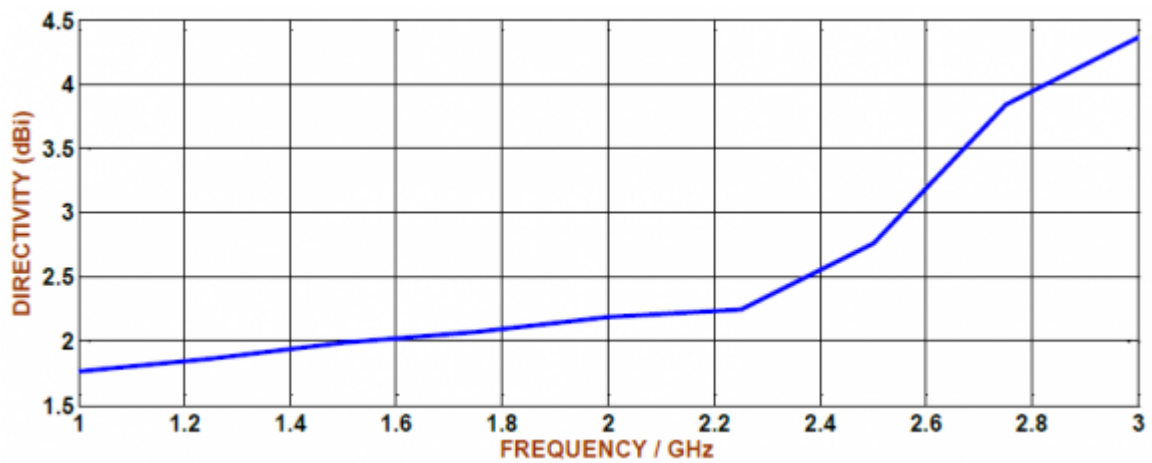

Figure 17: Fig



12

Figure 18: Fig. 12 :



13

Figure 19: Fig. 13 :

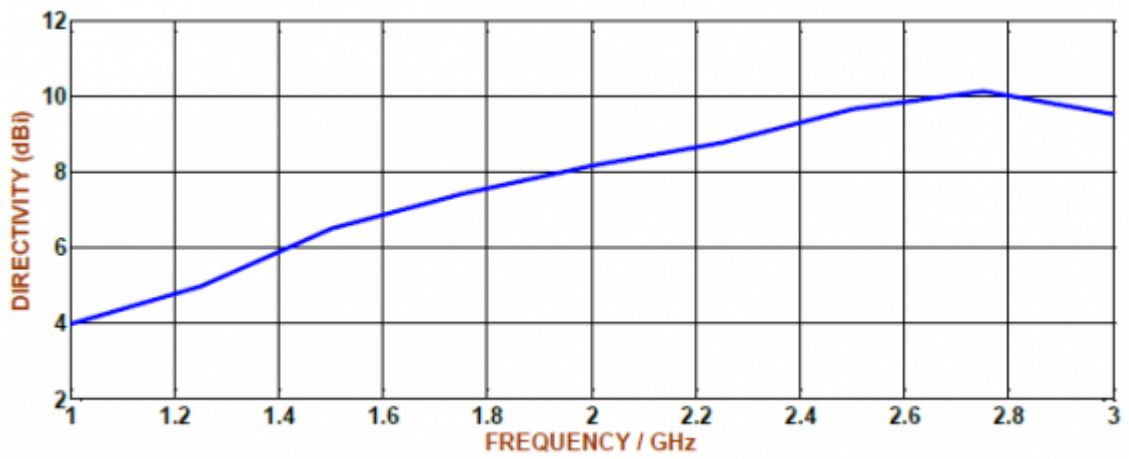

14

Figure 20: Fig. 14 :

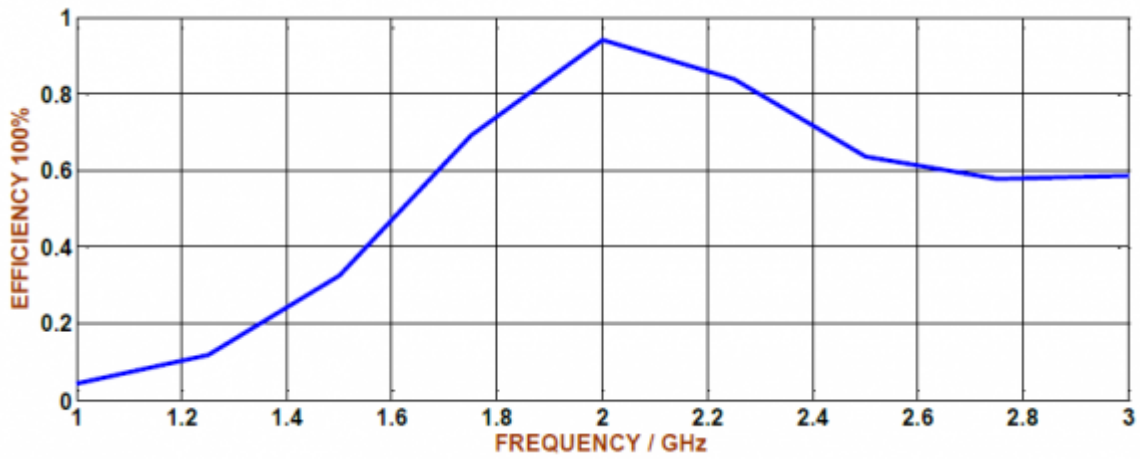

14

Figure 21: Fig. 14 :

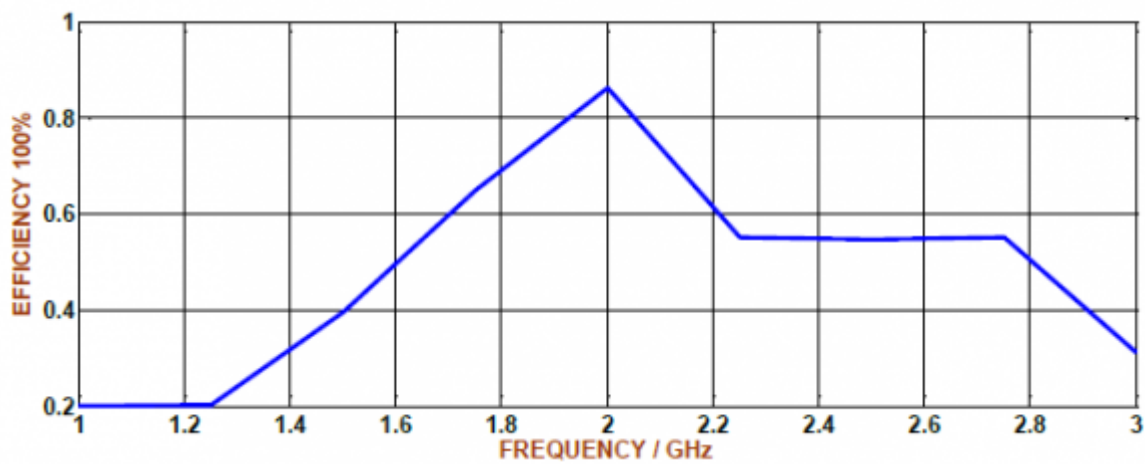

13

Figure 22: Fig. 13 :

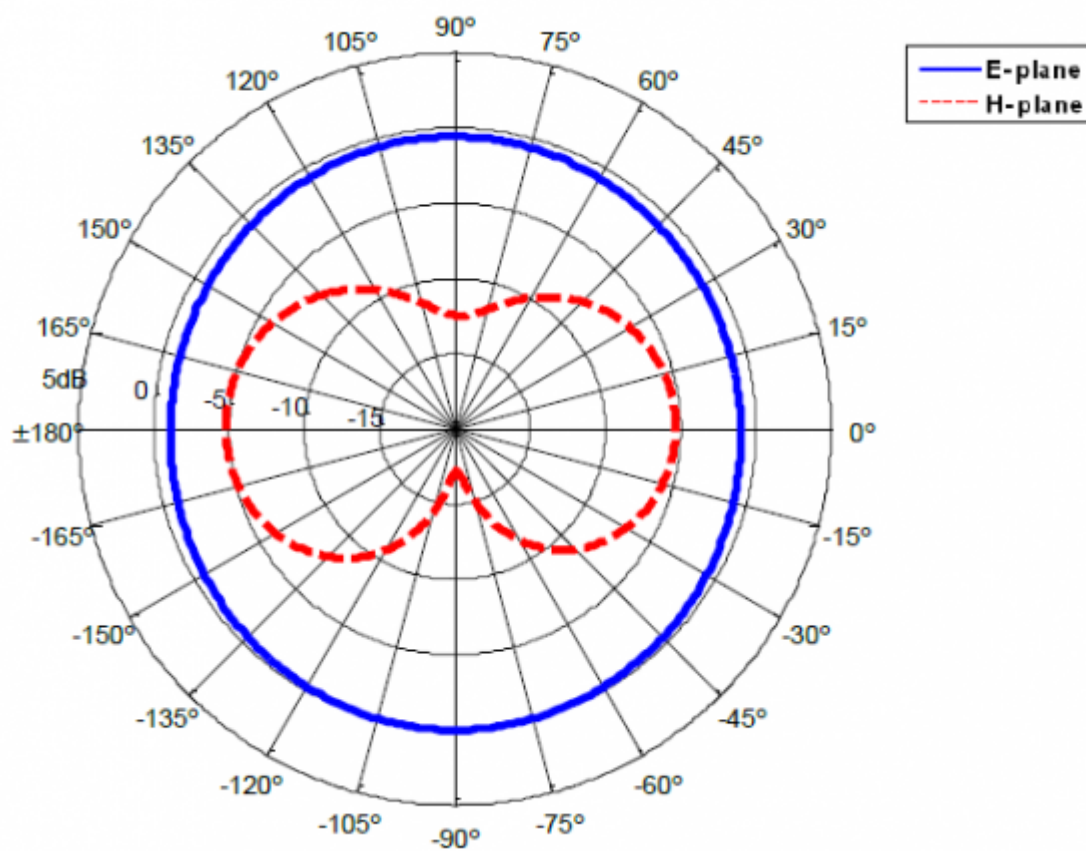

15

Figure 23: Fig. 15 :

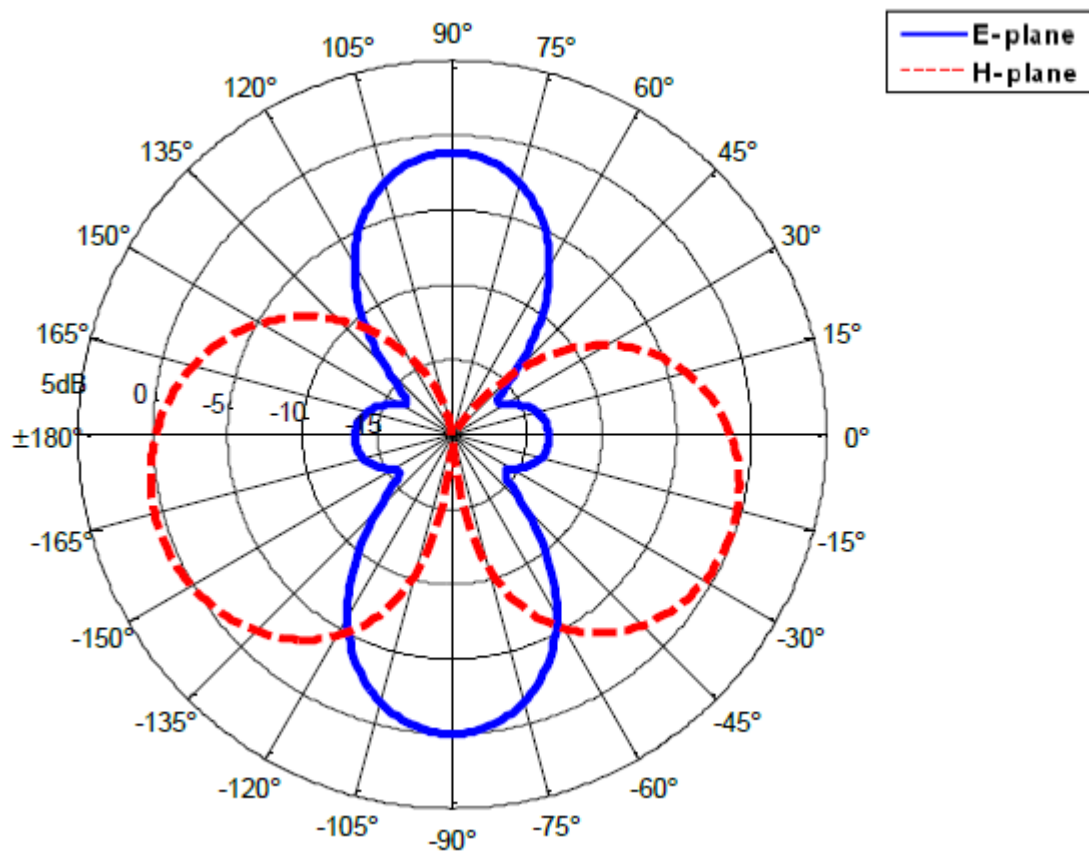

15

Figure 24: Fig. 15 :



16

Figure 25: Fig. 16 :

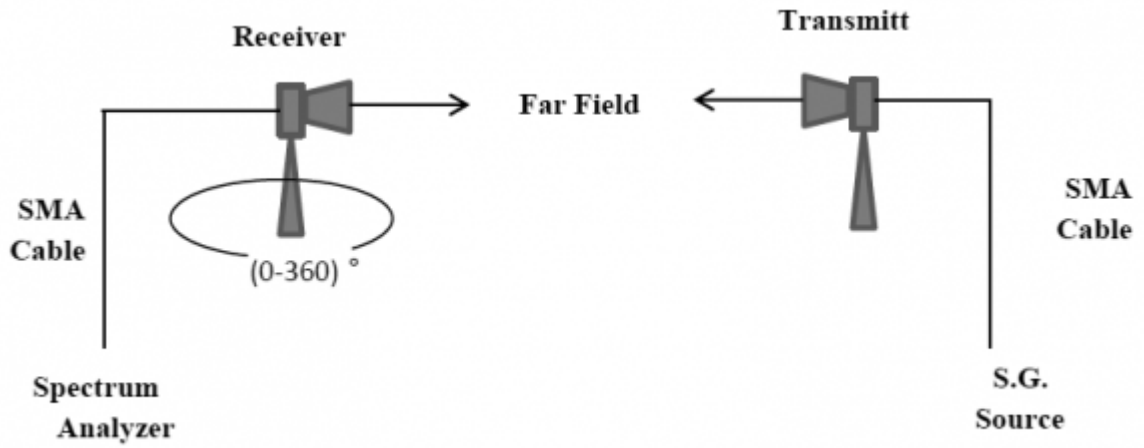

1718

Figure 26: Fig. 17 :Fig. 18 :

1

Figure 27: Table 1 :

2

Antenna	Simulated gain (dB)	Measuring gain (dB)
Single Microstrip Antenna	2.206	2.04
Array Microstrip Antenna	8.506	8.313

Figure 28: Table 2 :

- 
- 121 [Pattanaik ()] 'A Study on The Engineering Techniques Adopted for Microstrip Antenna for Achieving Some  
122 Specific Performance for Commercial/Personal Communication'. S Pattanaik . *European Journal of Applied*  
123 *Engineering and Scientific Research* 2012. 1 p. .
- 124 [Balanis ()] *Antenna Theory Analysis and Design*, C A Balanis . 2005. John Wiley & Sons. (3rdEdition)
- 125 [Kumar and Ray ()] *Broadband Microstrip Antenna*, G Kumar , K P Ray . 2003. Artech House.
- 126 [D. Singh and A. Kumar and others ()] 'Design and Analysis of Linear Array of Two S-Shaped Microstrip  
127 Patch Antenna'. *International Journal of Advanced Research in Electrical, Electronics and Instrumentation*  
128 *Engineering* D. Singh and A. Kumar and others (ed.) 2013. 2 (9) .
- 129 [Huque ()] 'Design and Simulation of a Low-cost and High Gain Microstrip Patch Antenna Arrays for the X-  
130 band Applications'. M T I Huque . *International Conference on Network Communication and Computer*  
131 *-ICNCC2011*, (New Delhi,India) 2011.
- 132 [Alam et al. ()] 'Gain Improvement of Micro Strip Antenna Using Dual Patch Array Micro Strip Antenna'. M  
133 M Alam , R Ahmmmed , M Toufikul . *Journal of Emerging Trends in Computing and Information Sciences*  
134 2012. 3 p. .
- 135 [Riblet ()] 'General Synthesis of Quarter-Wave Impedance Transformer'. H J Riblet . *IRE Transactions on*  
136 *Microwave Theory and techniques*, 1957. 5 p. .
- 137 [Yepes ; Georgia and Kraus ()] *Multilayer Antenna Array for Environmental Sensing Application*, M A Yepes ;  
138 Georgia , , J D Kraus . 2010. McGraw Hill. (Antennas)