

# Review on Characteristic Modeling of Electric Arc Furnace and its Effects

K U Vinayaka<sup>1</sup>

<sup>1</sup> Siddaganga Institute of Technology

*Received: 8 December 2017 Accepted: 5 January 2018 Published: 15 January 2018*

---

## Abstract

Development on a country is based on its industrialization and infrastructure; steel is used as a vital part of any building infrastructure, the process of steel manufacturing using electric arc furnace (EAF) introduces several power quality disturbances, in this paper, characteristic modeling of electric arc furnace and its effects on power quality is investigated. Several EAF models are modeled and reviewed from power quality assessment. Voltage flicker, Harmonics and Inter harmonics arises in an electrical network due to the non-linear nature of EAF operation. Time-domain modeling and frequency domain modeling of an EAF is simulated using MATLAB/ SIMULINK and PSCAD simulation software.

---

**Index terms**— electric arc furnace (EAF); powerquality (PQ); voltage-current (V-I); voltage current characteristics (VIC);

## 1 I. INTRODUCTION TO POWER QUALITY

he modern-day equipments are automatic and semiautomatic in nature and are expensive too, which are vulnerable to the changes in the input power supply. As these machines are the workhorse of any industry, the productivity and economics are dependent on these machines. The malfunctioning/ damage to this sensitive equipment puts the work into the halt. In this regard, it is essential to provide the quality input to the machines for stable and reliable operation.

The term "Power Quality" deals with the quality of the power distributed and delivered to the end users, there are many factors that disturb the quality of the power delivered commonly called as power quality disturbances. Generally the power quality refers to the voltage quality and the current quality, as an end user we cannot ensure the current quality as it depends on the type of the load connected to the system, so as to improve the overall power quality it is the need of the hour to maintain a proper voltage quality so as to uplift the overall power quality.

The major threats to the power quality are the long and short duration voltage variations, harmonics, inter-harmonics etc.

A Phenomenon associated with light intensity caused due to the non-linear and stochastic behavior of EAF is commonly termed as voltage flickers. Flicker causes the voltage fluctuations at PCC and disturbs consumers by causing flicker of bulbs and lamps.

Voltage flicker is characterized by fluctuations of voltage below 0.5% in the frequency range of 5-10Hz.

An Unbalanced and periodically varying load such as EAF disturbs the quality of power system; the operation of an EAF introduces voltage flicker, unbalance, characteristic and noncharacteristic harmonics to the system thereby degrading the quality of the power delivered at the consumer end.

To investigate the voltage flicker and harmonics introduced by an EAF, the characteristics of EAF operation is to be understood. Therefore an attempt is made to model different kinds of EAF models and study its behavior. The harmonic spectrum exhibits the characteristics and non-characteristics harmonics under different stages of operation, the total harmonic distortion during the melting stage is comparatively higher than during the refining stage.

### 2 II. ELECTRIC ARC FURNACE

The EAF is used in Steelmaking has emerged as an important steelmaking process in recent years. One of the methods is through production of electric arc which gives an arc temperature between 3000C to 3500C. Arc is the flow of current through an air gap between two electrodes.

In brief, when an AC Current is applied through the electrodes, an arc gets struck between the Graphite electrode and metal scrap, thereby inducing a very high temperature heat to melt the scrap /charge into molten metal, the electrical energy required during the process of steel making is tremendously large and is dependent on the quantity of the charge to be melted.

The process of steel making is very chaotic in nature characterized by large and sudden variations in currents and voltages disturbing the power grids.

The disturbances due to high nonlinearity of the EAF load affects the Sub transmission and transmission of overall power system network.

The variations of voltage both with respect to magnitude and frequency are the characteristics of voltage flicker, and the injection of integral and fractional multiples of fundamental frequency components of supply voltage is termed as voltage harmonics and voltage inter harmonics.

The arc resistance of an EAF is highly variable making The V-I characteristic be non-linear, thereby introducing harmonic currents, resulting in voltage harmonics due to circulation of harmonic currents in an electrical network.

### 3 III. MODELING OF ELECTRIC ARC FURNACE

An unbalanced and periodically varying load such as EAF injects disturbances to the system leading to degradation of the quality of power system.

To understand the randomness in operation of an EAF it is essential to build the characteristic model of an electric arc furnace.

The process of arc melting is stochastic and is hard to realize an accurate model for EAF load.

Stages of steel making process, the position of the electrodes, nature of the supply voltage, and system impedance are the critical parameters to be considered for modeling of an EAF with regards to electrical power quality .

Also For any characteristic model the accuracy of the characteristics model depends on the least assumptions made during modeling process, lesser the number of assumption closer will be the model with the actual characteristics of EAF.

Thus, the description of an arc furnace load depends on the following items: arc voltage, arc current and arc length (which is determined by the the position of electrode).

In general the models can be classified into, IV.

### 4 MODELING OF ARC FURNACE ON SIMULATORS a) Introduction to modeling of Electric Arc Furnace on Simulators

Detailed electrical operations of an EAF have been outlined in the preceding sections. As evident, the EAF is unbalanced, highly nonlinear, periodically varying load. Since such random behavior is difficult to be realized on a simulator, many researchers have published various models that can be used to simulate the characteristics.

### 5 The models may be classified as:

1. Based on the V-I characteristics.
2. Based on the time domain nonlinear equivalent circuit
3. Based on the harmonic voltage source method.
4. Based on the Harmonic domain solution of a nonlinear differential equation.
5. Based on the Random process.

The V-I characteristic models are derived from the relation between arc voltage and arc current using the V-I characteristics. The static and dynamic operation of an EAF is usually realized using VIC.

The time domain equivalent circuit model is also based on the V-I characteristics. The approximation made in this type of modeling is more than that made in the previous type and hence this is very simple model.

Both is derived from experimental formula. This method is highly dependent on the system parameters and operating conditions.

The random process model reflects the model of arc furnace during the early stage of meltdown period. It has been mainly used for voltage flicker analysis

### 6 b) Model based on the V-I characteristic

The model based on the solution of nonlinear differential equation closely approximates a practical arc furnace, hence this is chosen for the simulation studies. This is justified in the following subsections where a comparison is made between the practical EAF and V-I characteristics of the same.

The real time V-I characteristics and linearized model of an EAF is as shown below. The arc length in the furnace operation determines the ignition and extinction voltage of an EAF.

Various time domain models can be derived by approximating the voltage-current characteristics of an EAF.

Figure 3 The EAF model analysis is approximated considering two linear equations on VI-characteristics of the EAF. The two linear equations are shown below, arc voltage as a function of currents for one cycle in this model is represented as,  $V = R_1 i + V_{i1}$  and  $V = R_2 i + V_{i2}$  where  $R_1$  is linear slope obtained when the V-I characteristic approximation is between the limits  $i_1$  : arc current reached at the ignition voltage of the electric arc (Vig) and  $i_2$  : arc current reached at the extinction voltage of the electric arc (Vex).

$R_1$  : linear slope obtained when the V-I characteristic approximation is between the limits  $i_1$  : arc current reached at the ignition voltage of the electric arc (Vig) and  $i_2$  : arc current reached at the extinction voltage of the electric arc (Vex).

## 7 Model 2

Further precise model can be achieved by reducing the number of approximations and considering the detailed variations of V-I characteristics EAF acts as a pure resistor, in the first stage where magnitude of the voltage rises from extinction voltage to ignition voltage. During this stage the polarity of an arc current change from -i3 to i1.

Initiation of melting process is considered as second stage of EAF operation, characterized by an exponential drop in voltage across the electrode leading to drop of arc voltage from Vig to Vst followed by an increase in arc current i1 to i2.

Normal arc melting process is regarded as third stage of EAF operation; here arc voltage tends to drop in a line of slope gradually from Vst to Vex.  $V = R_3 i + V_{i3}$  where  $R_3$  is linear slope obtained when the V-I characteristic approximation is between the limits  $i_3$  : arc current reached at the extinction voltage of the electric arc (Vex) and  $i_2$  : arc current reached at the ignition voltage of the electric arc (Vig).  $V = R_4 i + V_{i4}$  where  $R_4$  is linear slope obtained when the V-I characteristic approximation is between the limits  $i_4$  : arc current reached at the ignition voltage of the electric arc (Vig) and  $i_3$  : arc current reached at the extinction voltage of the electric arc (Vex).

Review on Characteristic Modeling of Electric Arc Furnace and its Effects

(3)(4)(5) (6) (7) (-i 1, i 1) [-i 2, -i 1] or [i 1, i 2]

Model 3 Hyperbolic Model:

Here, the V-I characteristics of EAF is Considered as  $V = \frac{A}{i} + B$ , where A and B are constants. Model 4 Exponential Model:

The VI-characteristics of the arc voltage is expressed as an exponential function given by,  $V = A e^{Bi}$  where A and B are constants.

I0: current constant is employed to realize the slope of positive and negative currents.

## 8 Model 5 Arc Resistance Model:

The non-linear resistance of an EAF is expressed as function of current source The V-I characteristics is shown. The equations pertaining to the operation of an EAF is as expressed below.  $I = |i(t)| e^{-t/\tau} = 1.15 e^{-t/\tau}$  where  $\tau$  is time constant.

Model 6

## 9 Exponential-Hyperbolic Model:

In this model, the combination of Hyperbolic and exponential is presented, the V-I Characteristics of this model is expressed by In this model, hyperbolic function describes the increase of the current and the exponential function describes the decrease of the current. The relation between arc length (l) and threshold voltage (T V) is explained by the given below expression.

## 10 T V = A + B \* l

A: constant evaluated as the sum of voltage sag for anode and cathode and is approximately 40 Volts.

B: voltage sag depended on the arc length and empirically is acceptable as B=10 V/cm and: arc length.

## 11 V. RESULTS AND DISCUSSION

The characteristics of various arc models can be studied by considering a simple EAF in single phase. The EAF system configuration is shown below. The system specifications and parameters of various models are as presented in the below table 1. It is observed that the V-I characteristics comprises of the linear region where the arc resistance remains constant between the ignition voltages, and arc resistances varies between the ignition and extinction voltages.

## 12 Model

1 represents the linearized characteristics of the actual EAF model; hence the accuracy of the model is far from the actual characteristics.

The corresponding Arc voltage and Arc current are shown in figure 6, it is observed that the arc voltage is distorted in nature, hence signifies the non-linearity in the system. As compared to the previous model, the differences are: A different electric arc functioning zone is defined;

In the case the value of the current is below  $-i_2$  or above than  $i_2$ , one can notice that the voltage variation is constant, maintained at the extinction voltage value of the electric arc;

The range in which the dynamic voltage-current characteristic can vary is larger. From the characteristic curve it is observed that the arc voltage is a hyperbolic function of an arc current and the characteristic curve has two curves forming the three zones of operation of an EAF, the curves for increasing and decreasing values of arc current with different constants under various operating conditions are simulated.

This model nearly resembles the actual V-I Characteristics of an EAF model, here it is also observed that, the arc voltage is far from sinusoidal similar to the previous models, hence higher order of harmonics. shows the exponential behavior of the arc voltage with respect to the arc current and the characteristic curve has two regions consisting of a linear and exponential regions, as the approximations are more, the accuracy of model with respect to actual characteristic is poor. The arc voltage curve has higher distortion, hence the presence of harmonics is considered to be high. In the first one, the electric arc voltage increases to the ignition voltage of the electric arc, so the electric arc reignites. Hereby, the other phase can take place.

In the second phase, the electric arc voltage has an exponentially drop from the ignition voltage of the electric arc to the Vex voltage. In this phase take place the melting process of the metals, electric arc voltage being stable. This segment is approximated with an exponential function with time constant  $\tau_1$ .

In the third phase of the electric arc working zone, the arc begins to be extinct; its voltage keeps dropping, process which can also be assumed to be represented by an exponential function with the time constant  $\tau_2$ .

Here it is observed that, the arc voltage is less distorted to the previous models.

Since all the regions of operation are considered for modeling, model-5 presents almost actual characteristics of an EAF. The dynamic characteristics of the Models 1,2,3,4,5 and 6 are represented in figure 17,18,19,20,21 and 22 respectively, the dynamic characteristics of the models are observed for constant modulation index with constant sinusoidal variation, the random flicker can be observed for random variation in the modulation index for the same characteristic model.

### 13 c) Harmonic Behavior of EAF system

The Three phase Test circuit of EAF connected supply system developed in Simulink is shown in Figure 23.

A controlled voltage source with resistive and inductive network is used to couple the generated flicker disturbance to a given phase of the power system line. For a three-phase system, three sets of controlled voltage source and resistive and inductive networks are required.

The electric arc furnace model can be implemented using the MATLAB function block and a sinusoidal block.

Each electric arc furnace MATLAB Function block represent each electrode at each phase; therefore, three MATLAB function blocks are required for each phase. The sinusoidal is used to model the flicker frequency and magnitude variation The harmonics introduced in the system can be studied by carrying out FFT analysis. Figure 26 and figure 27 shows the harmonic spectrum of Arc voltage during smelting and refining process, It is observed that these results resembles the theoretical studies of an EAF, the harmonic spectrum consists of both the characteristic and noncharacteristic harmonics and inter-harmonics.

It is observed that due to high non linearity at the melting stage of an arc furnace the Total harmonic distortion is high and the THD reduces during the refining stage.

## 14 VI. CONCLUSIONS

EAF is a highly nonlinear, timely varying load with stochastic behavior introducing several power quality disturbances to the system.

Several models based on Voltage current characteristics and few current source models are modeled to investigate the voltage flicker and harmonics introduced into an electrical network by an EAF.

The static and dynamic behavior of the arc furnace models are studied and the results obtained indicates the existence of voltage flicker in the system, harmonic analysis is carried out to determine the current harmonics under different stages of EAF operation.

Various models of Electric Arc furnace resembles the actual characteristics of an EAF, out of the various models model 5 puts forward the précised result.

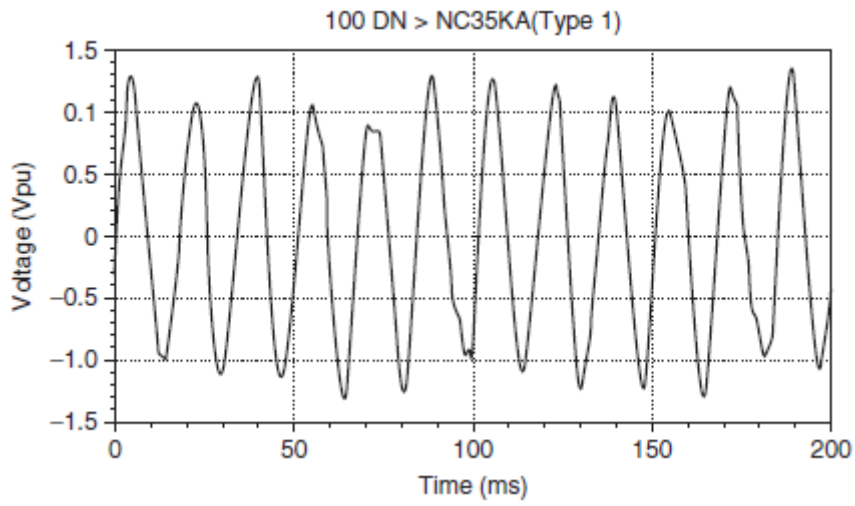

1

Figure 1: Figure 1

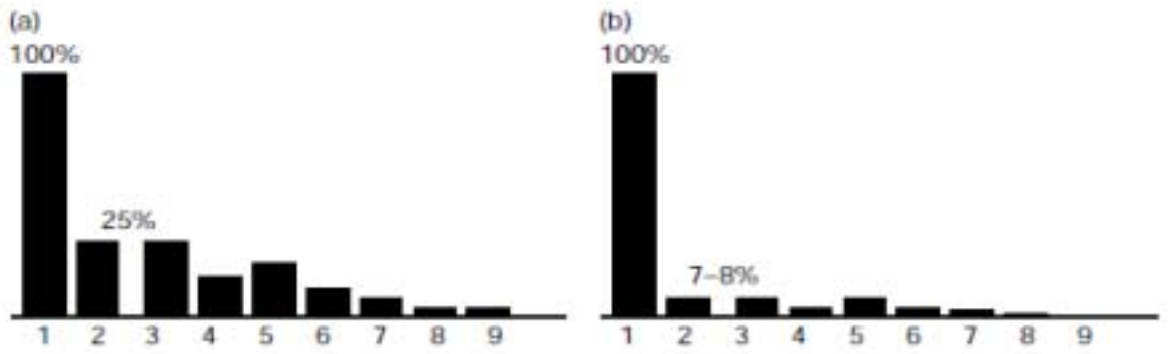

1

Figure 2: Figure 1 :

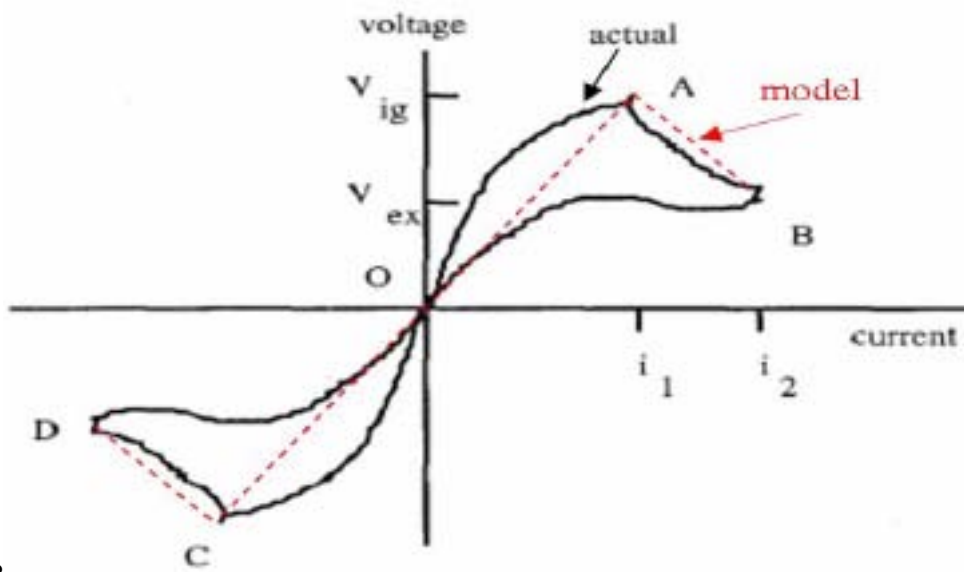

2

Figure 3: Figure 2 :

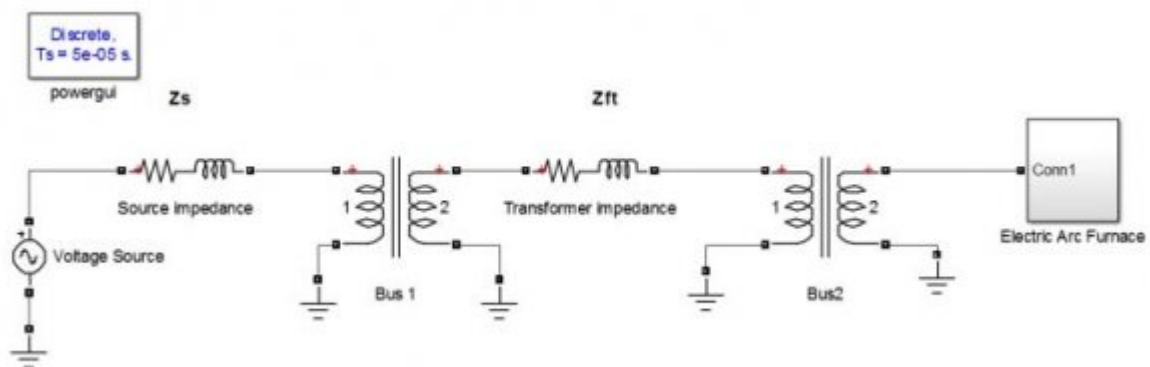

Figure 4:

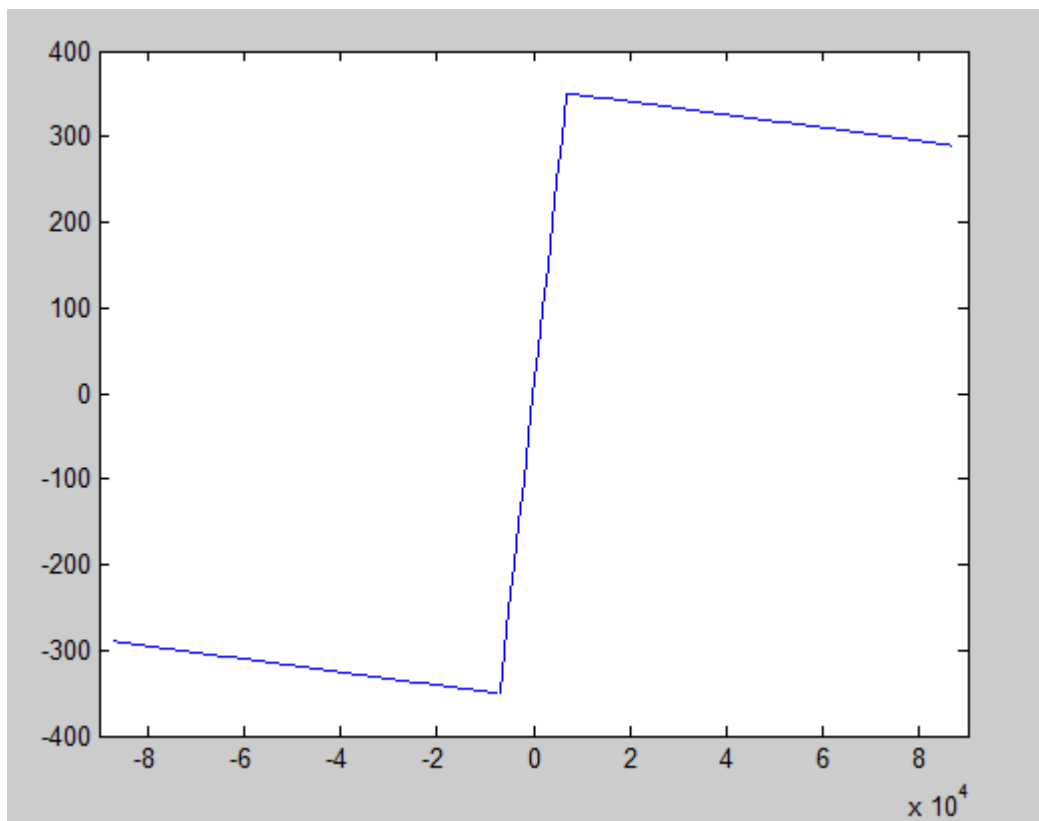
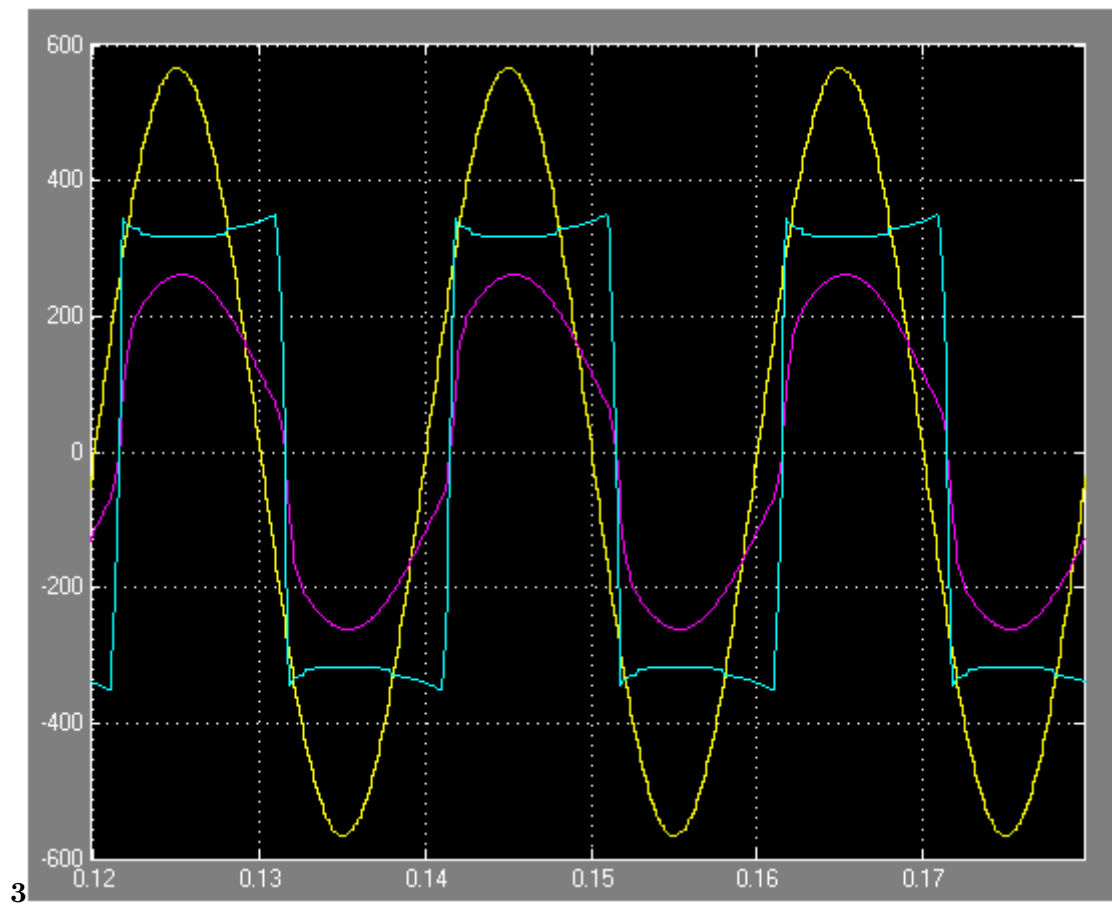

Figure 5:



3

Figure 6: Figure 3 :

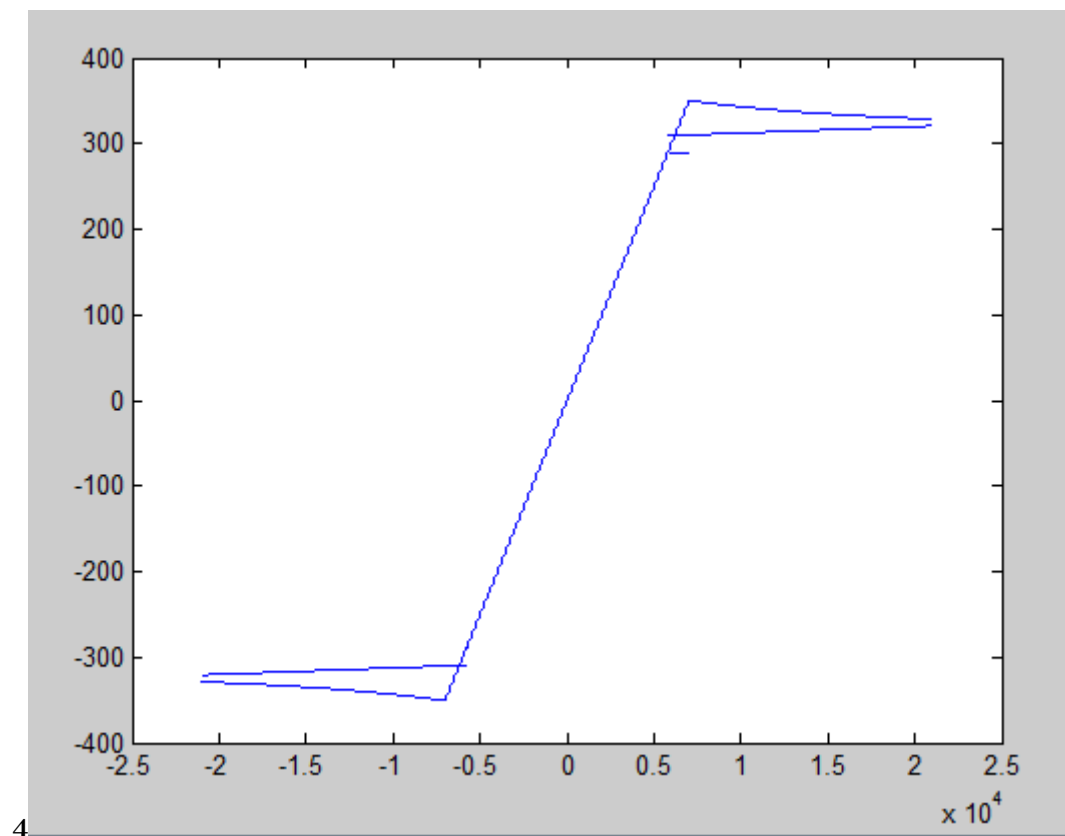

Figure 7: Figure 4 :

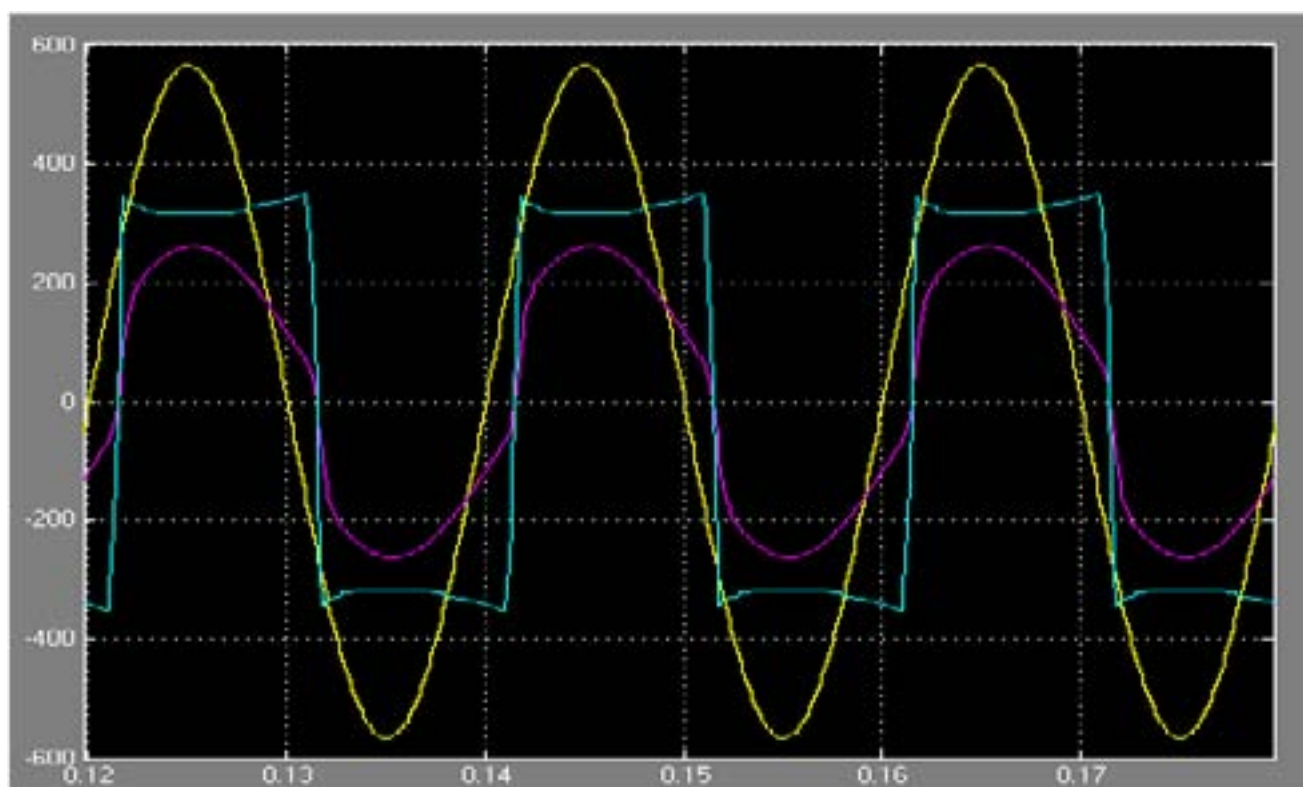
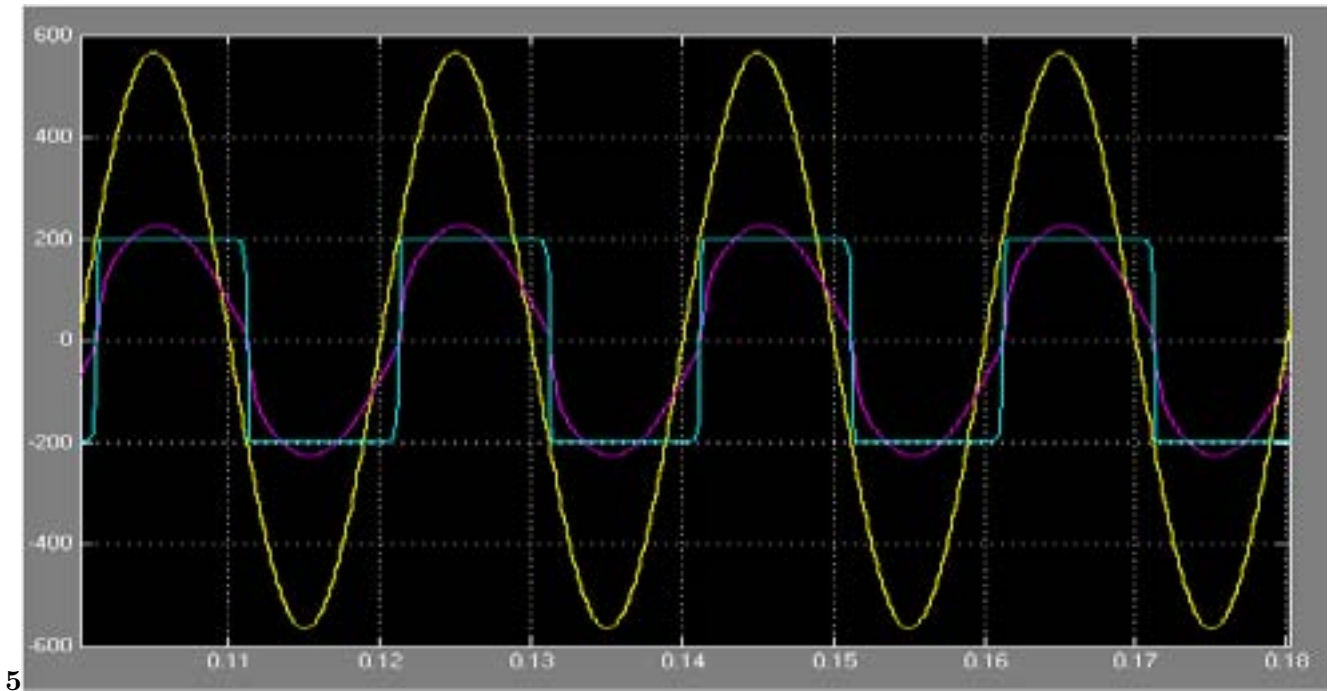
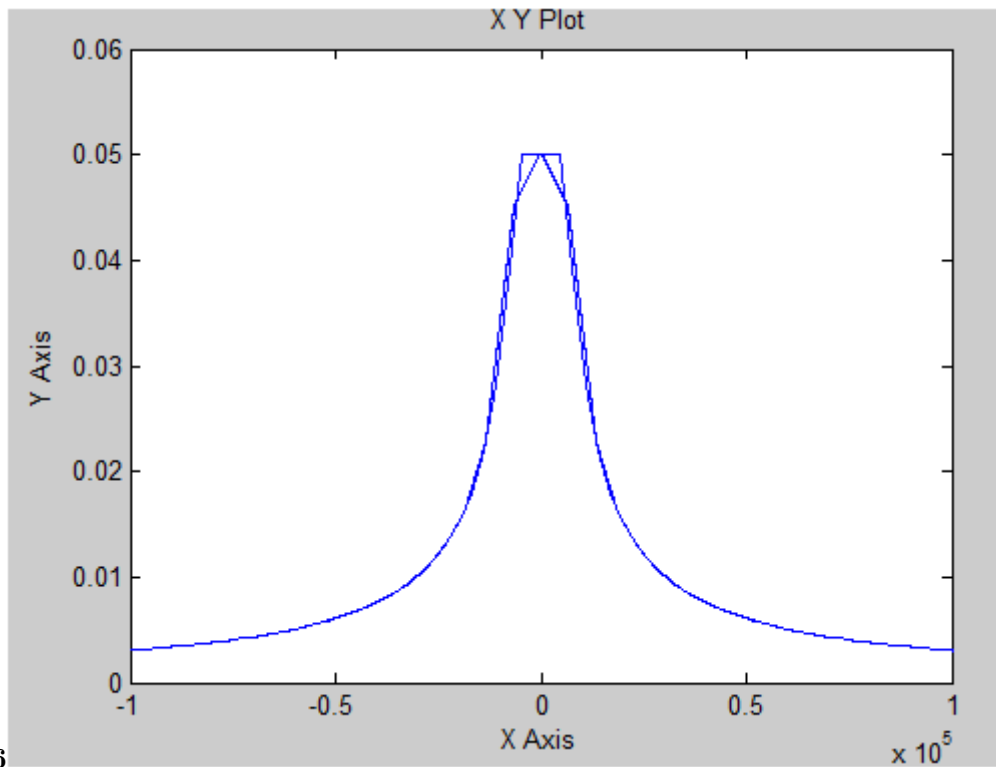

Figure 8: F



5

Figure 9: Figure 5 :



6

Figure 10: Figure 6 :

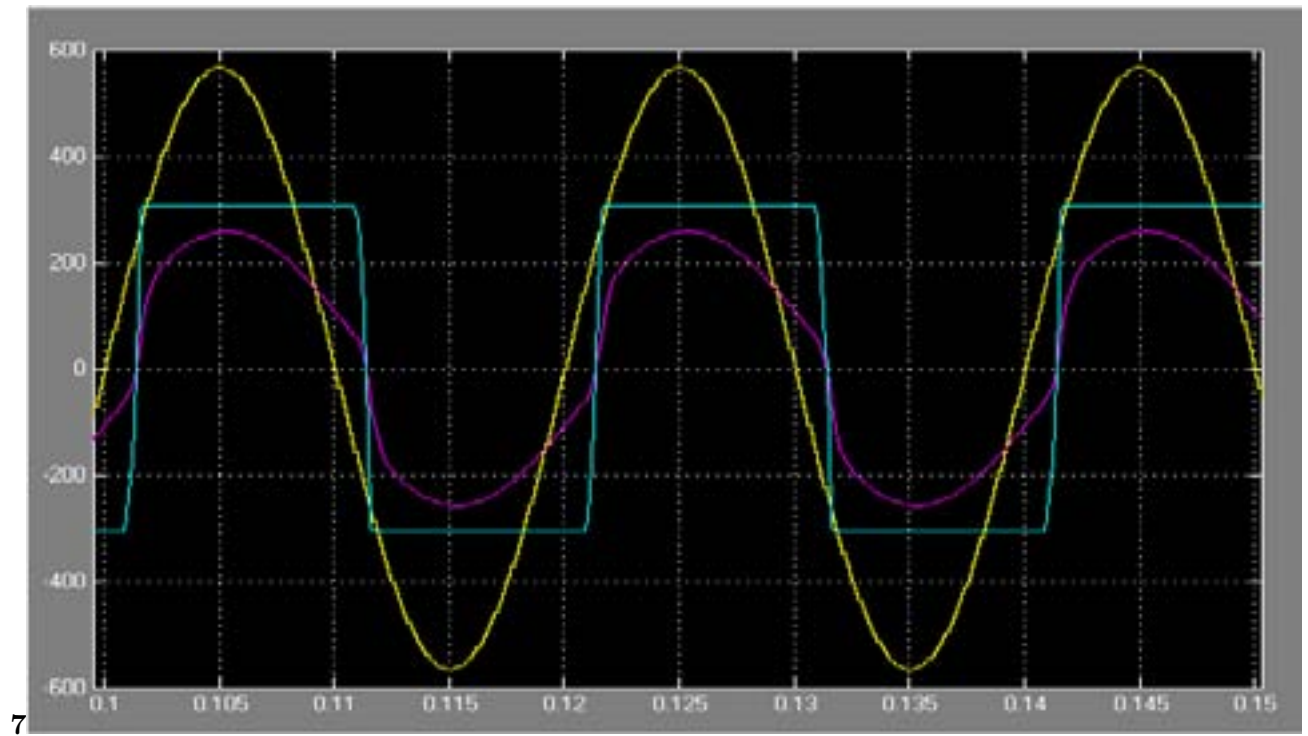

Figure 11: Figure 7 :

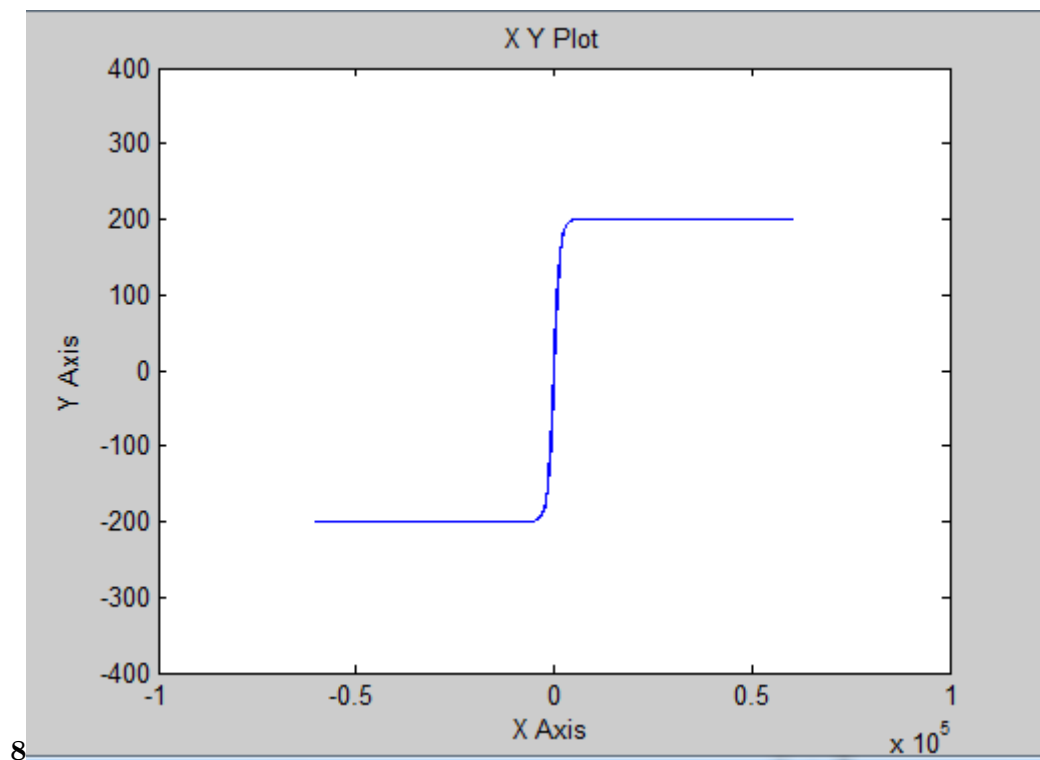

Figure 12: Figure 8 :

2018

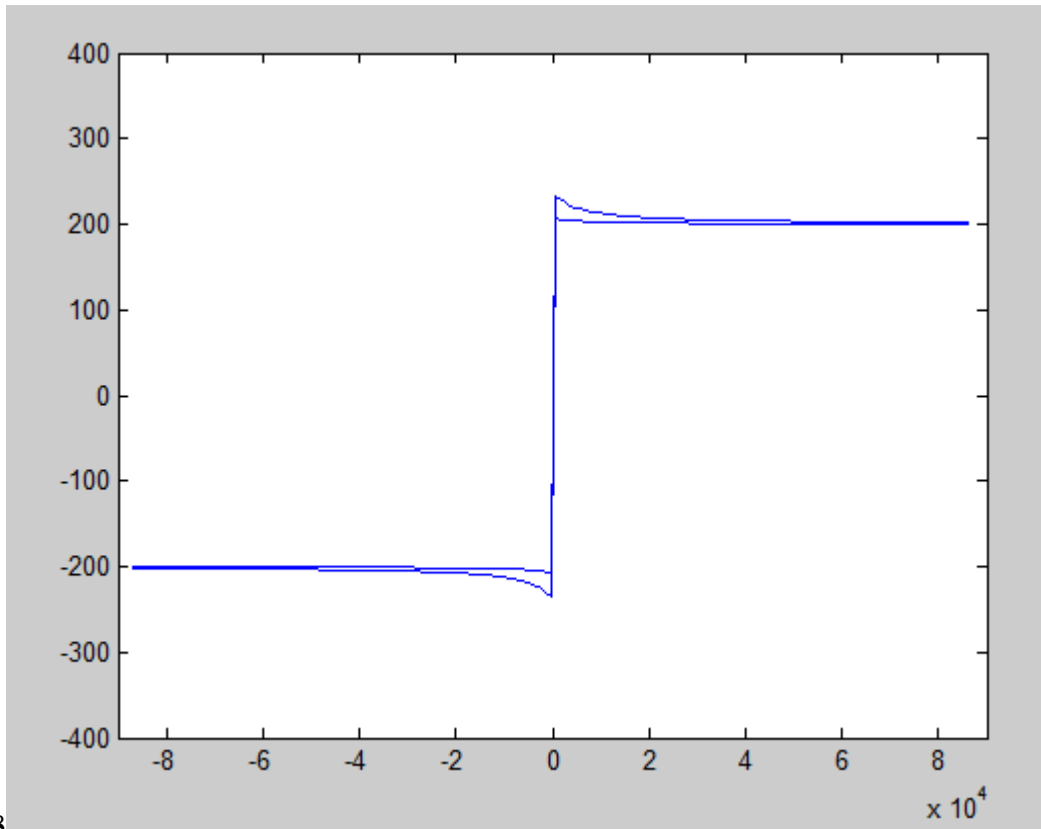

Figure 13: Year 2018 F

10

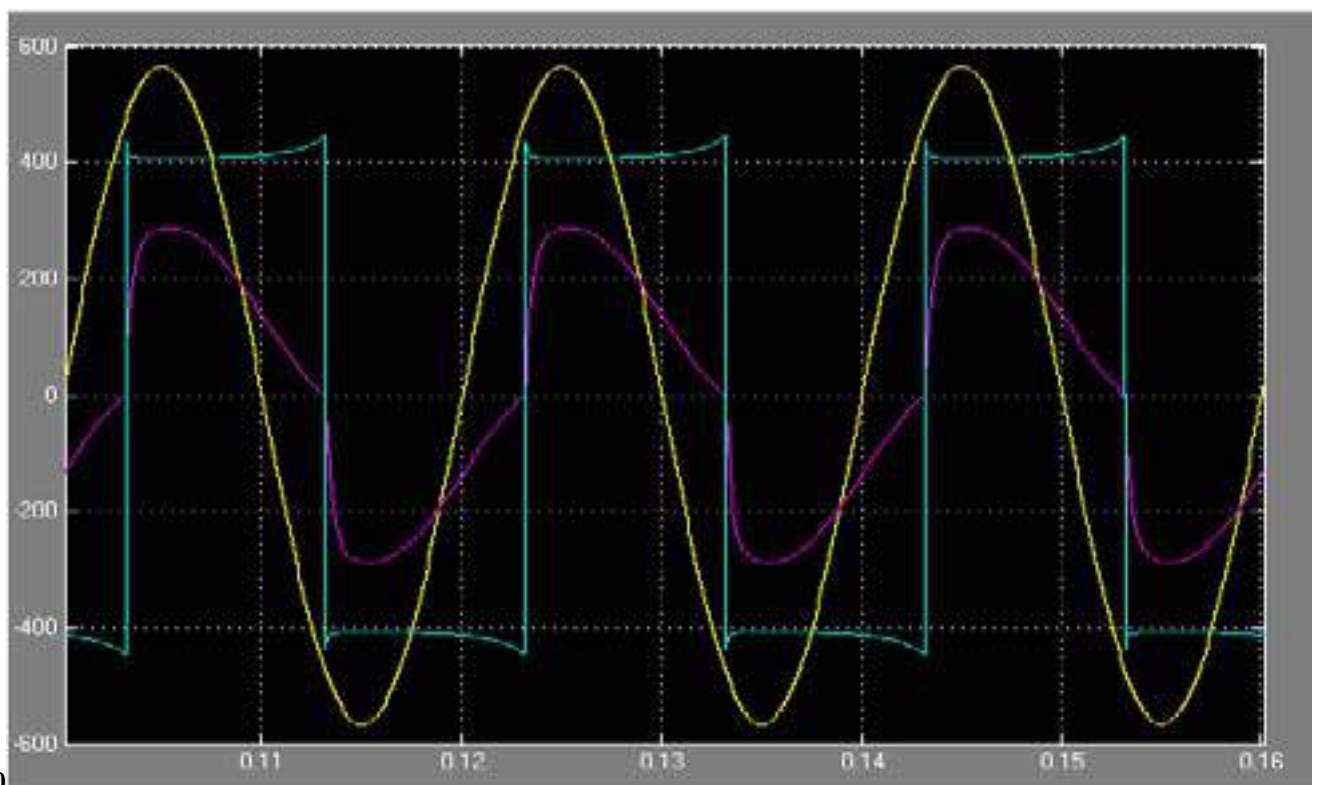

Figure 14: Figure 10 :

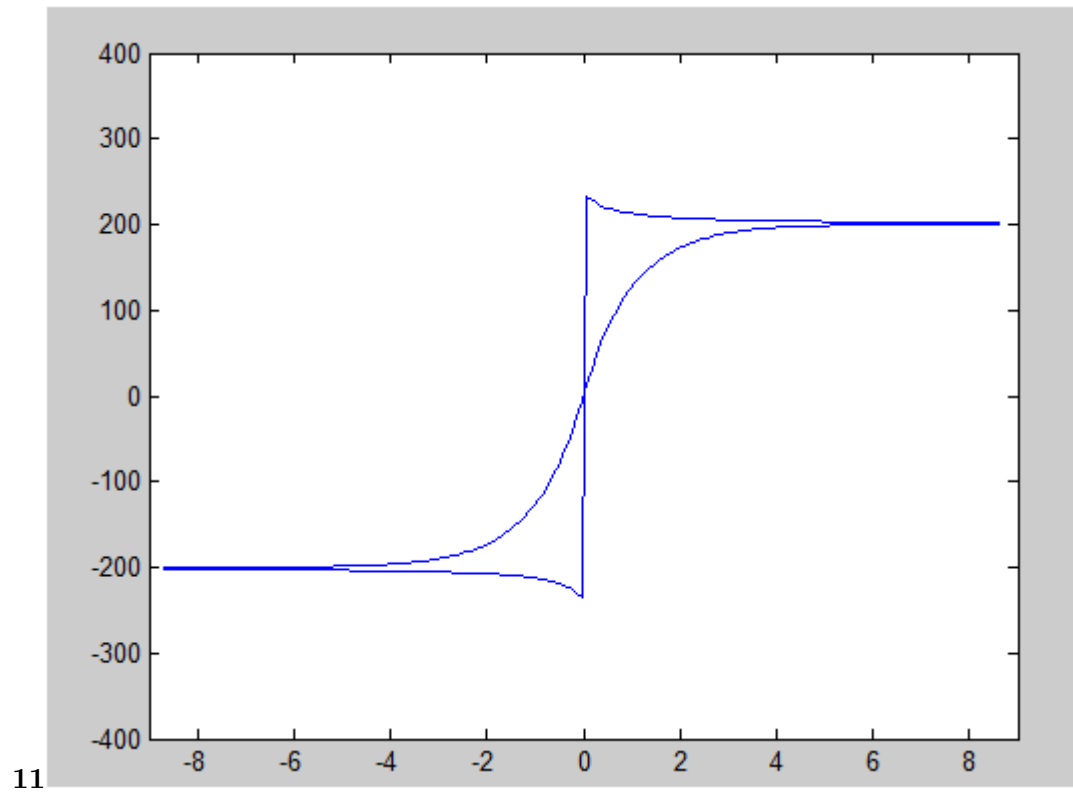

Figure 15: Figure 11 :

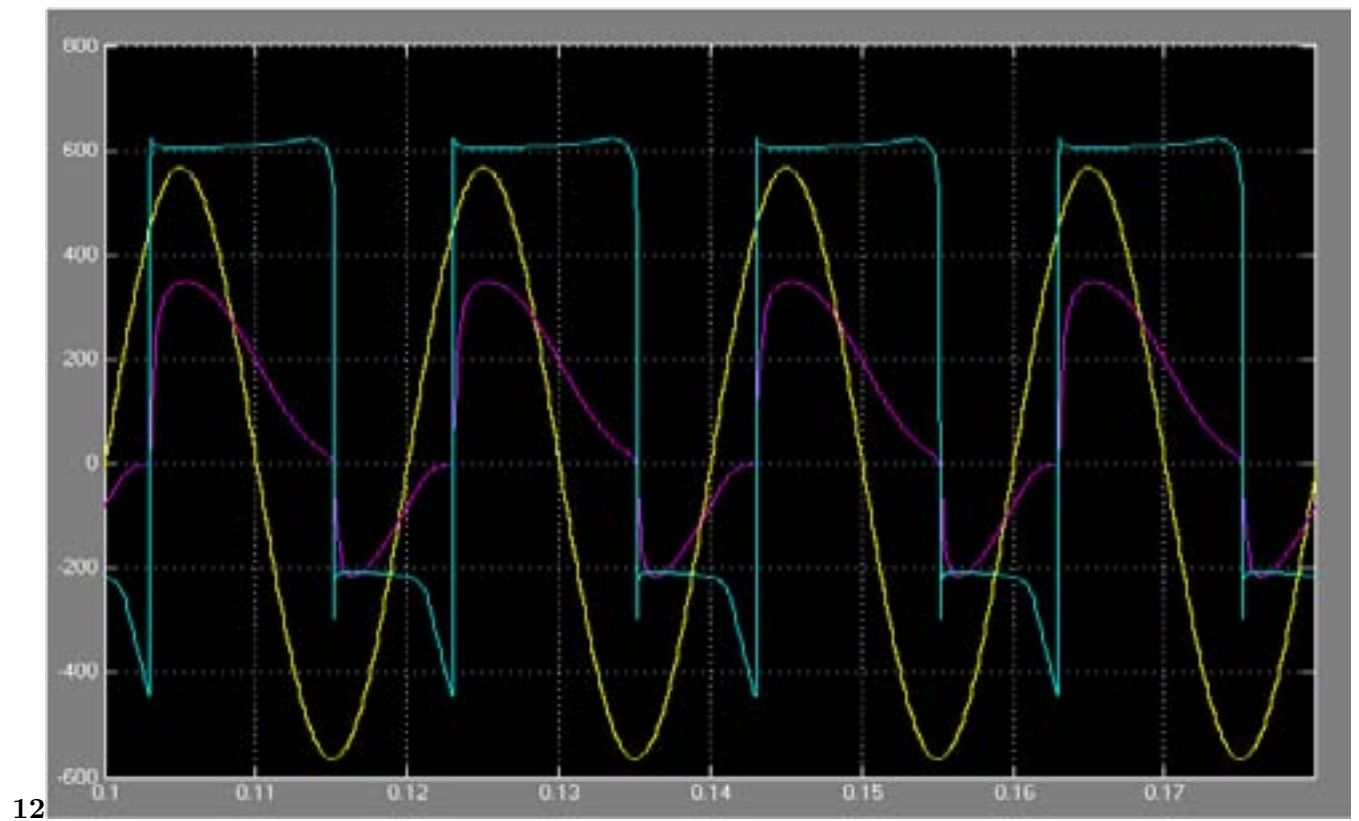

Figure 16: Figure 12 :

13

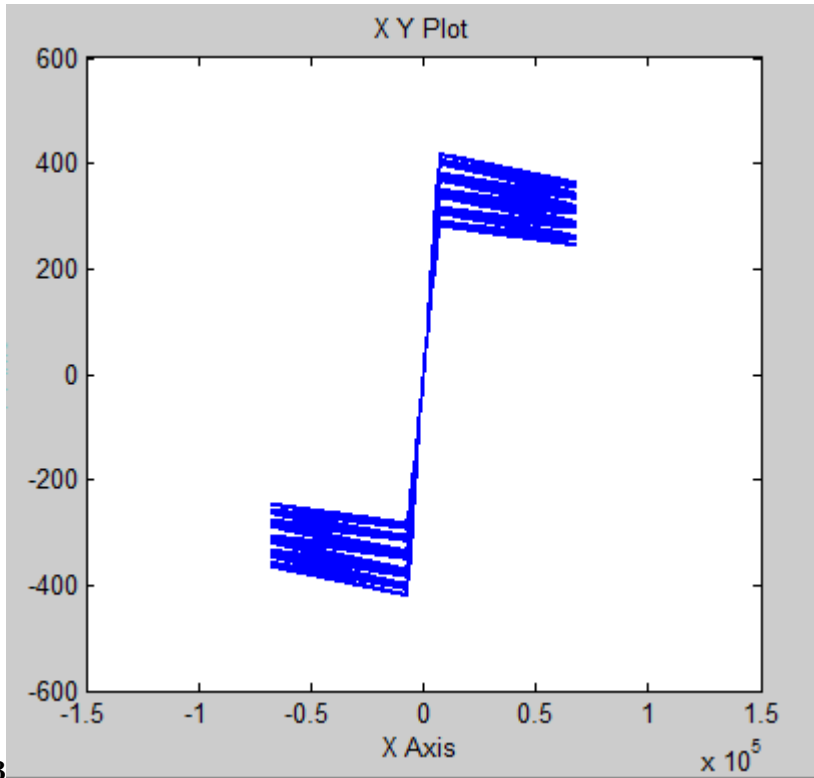

Figure 17: Figure 13 :F

15

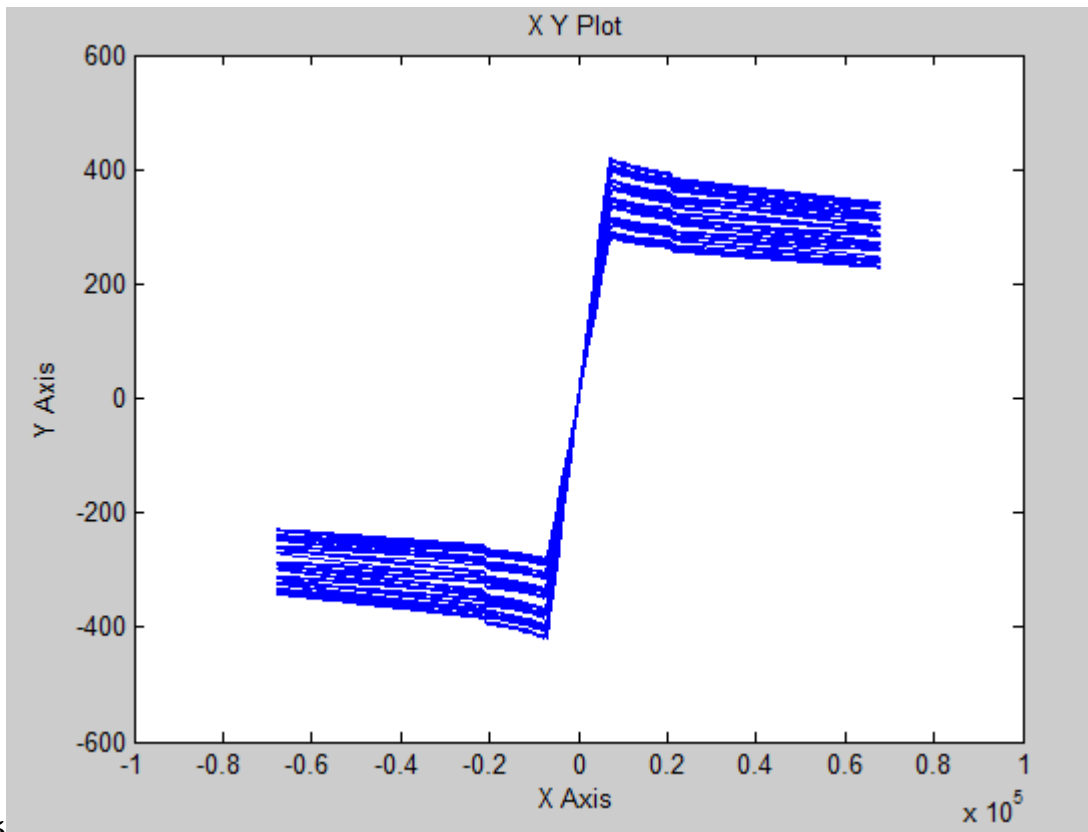

Figure 18: Figure 15 :

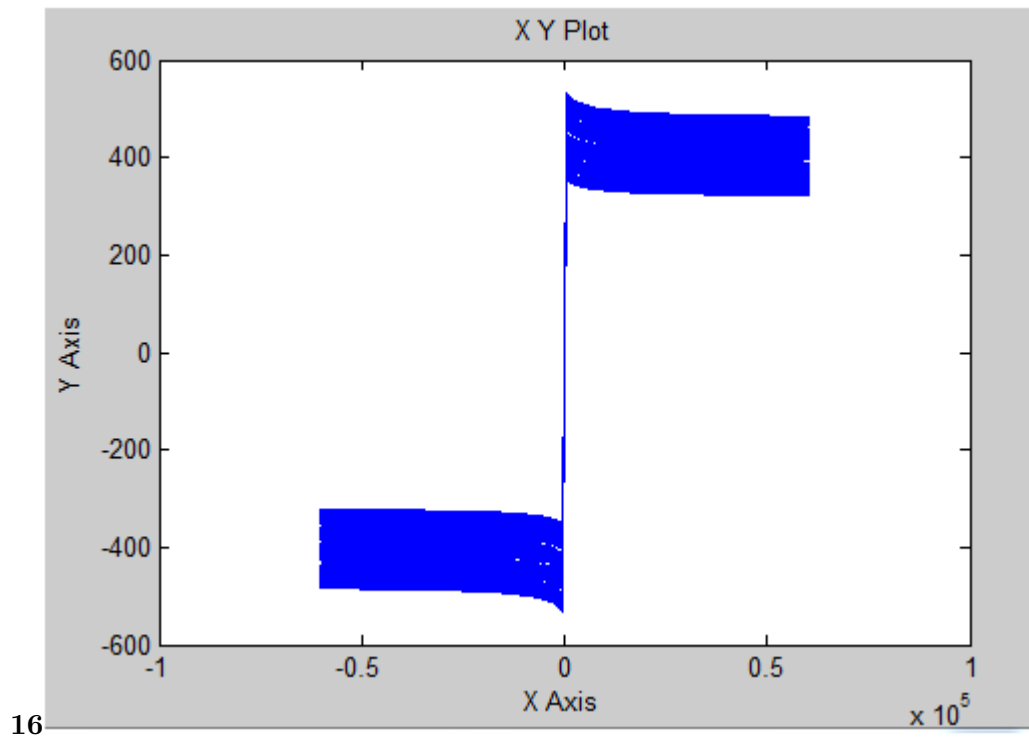

Figure 19: Figure 16 :

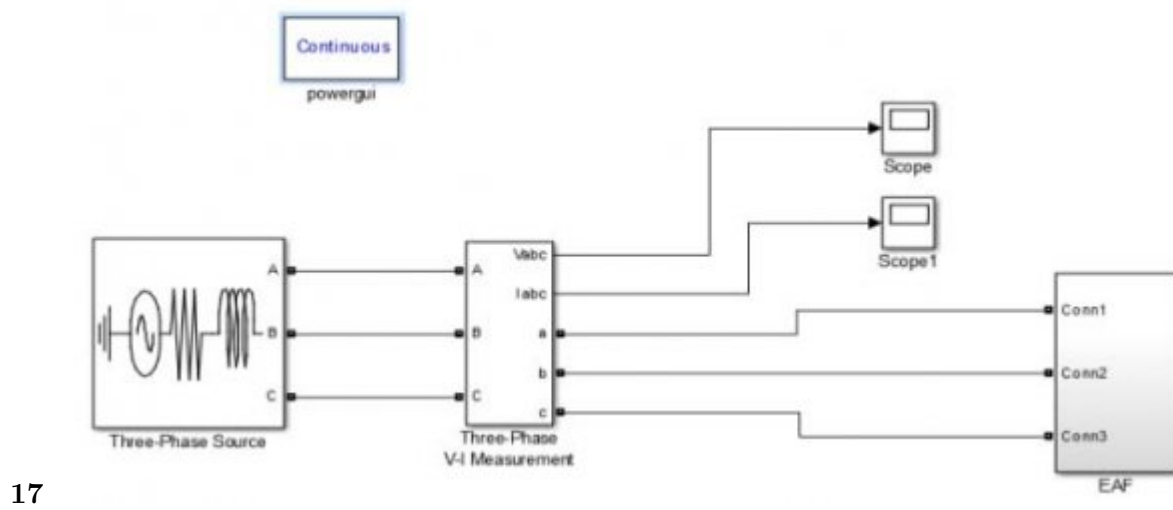
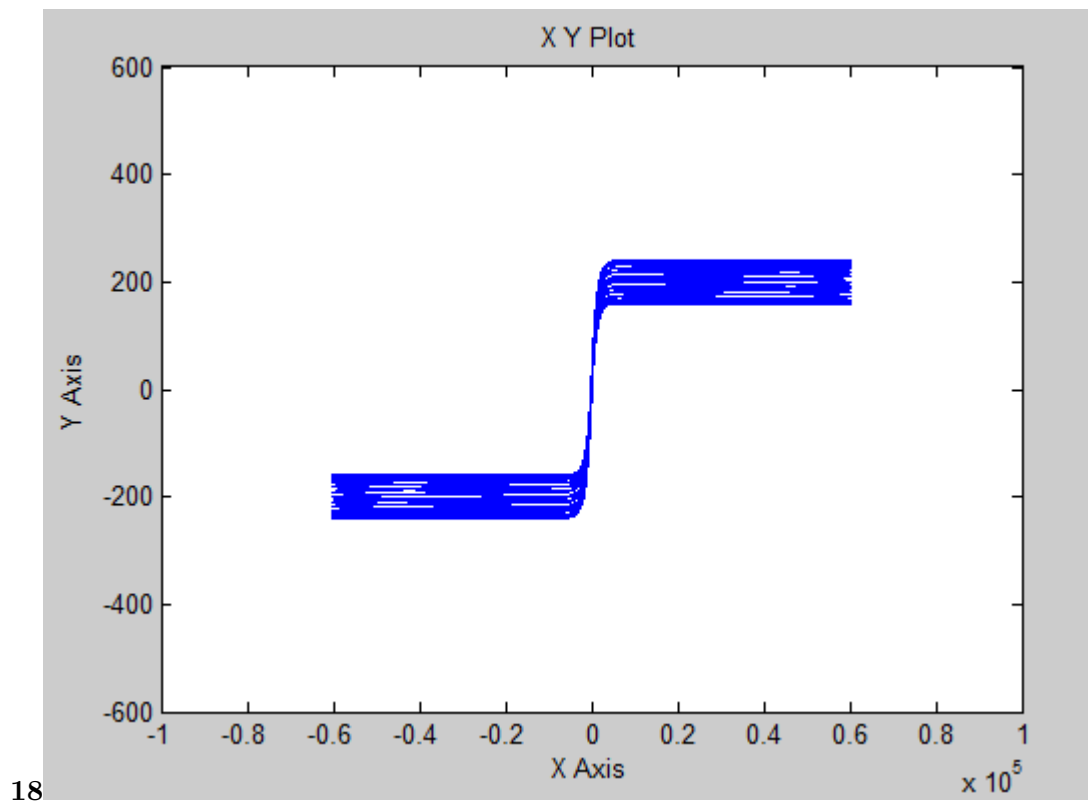
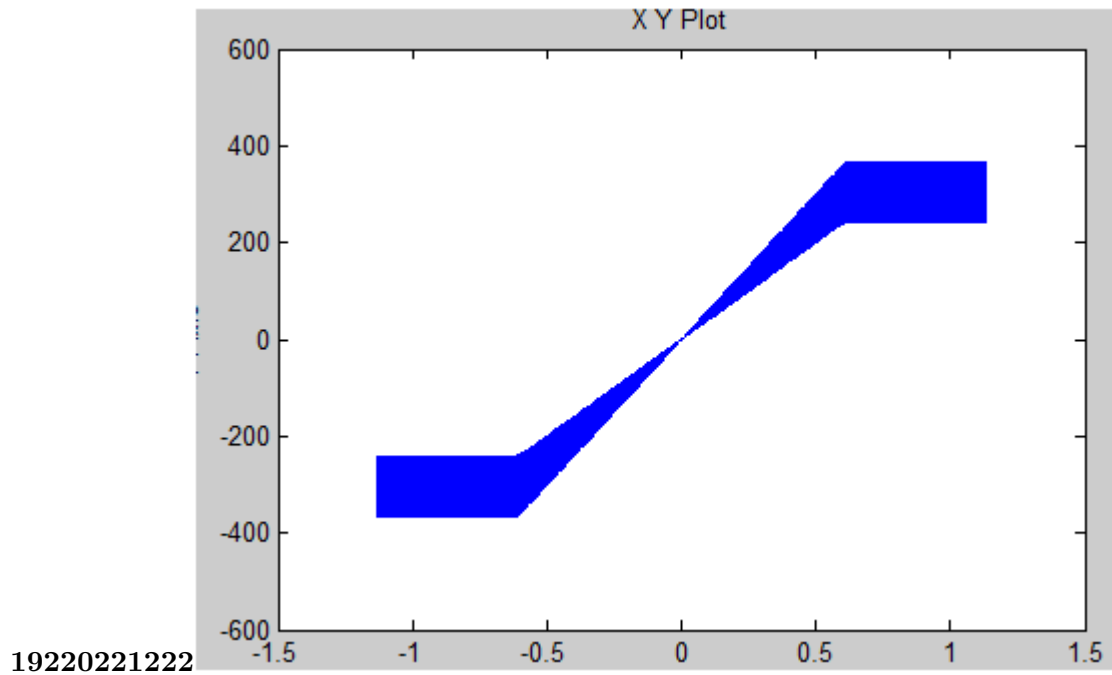

Figure 20: Figure 17 :



18

Figure 21: Figure 18 :



19220221222

Figure 22: Figure 19 : 2 Figure 20 : 2 Figure 21 : 2 Figure 22 :

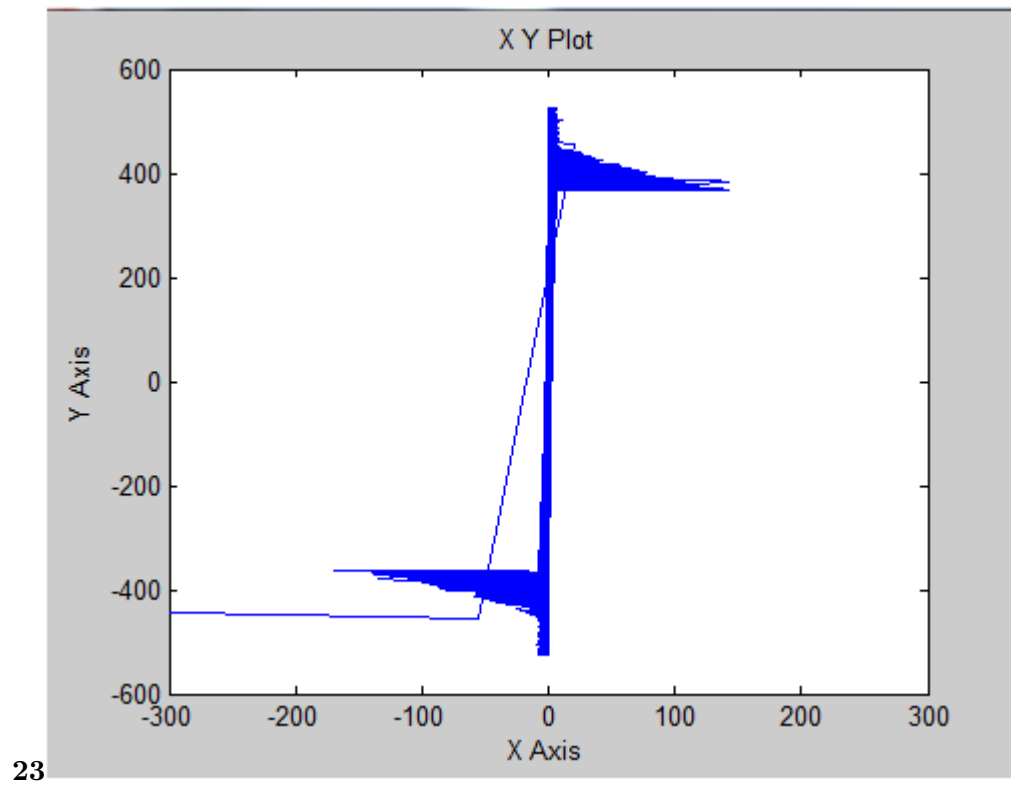

Figure 23: Figure 23 :

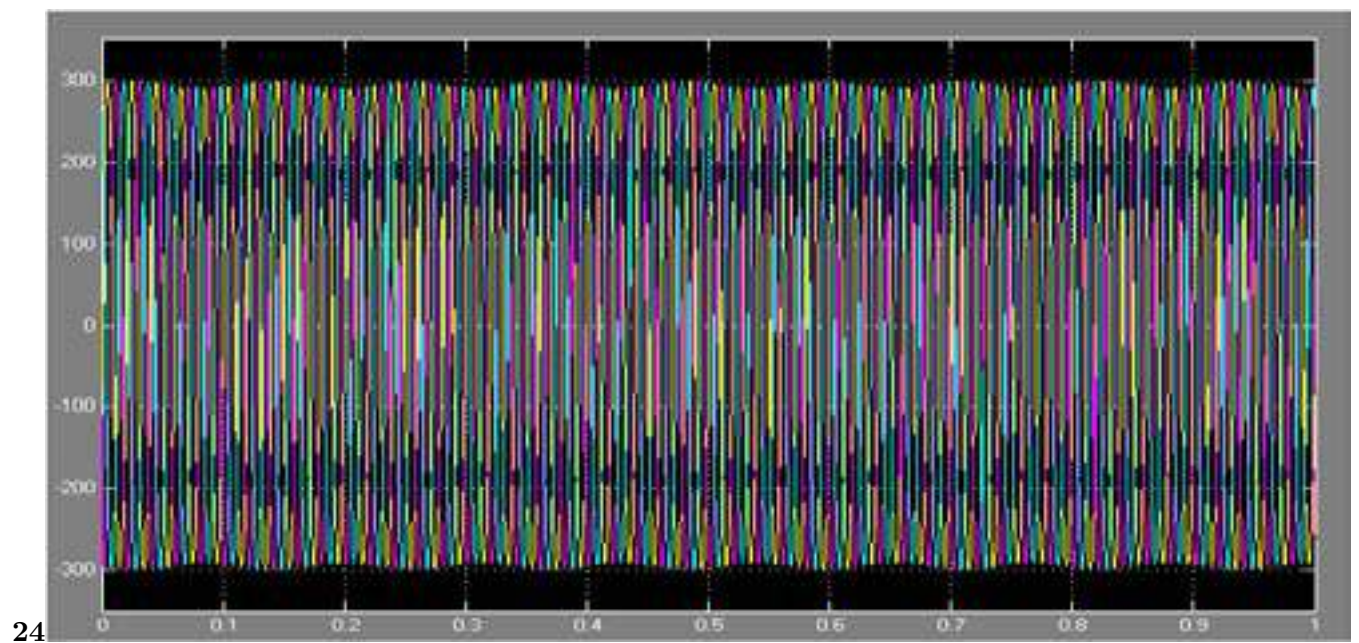

Figure 24: Figure 24 :

---

2527

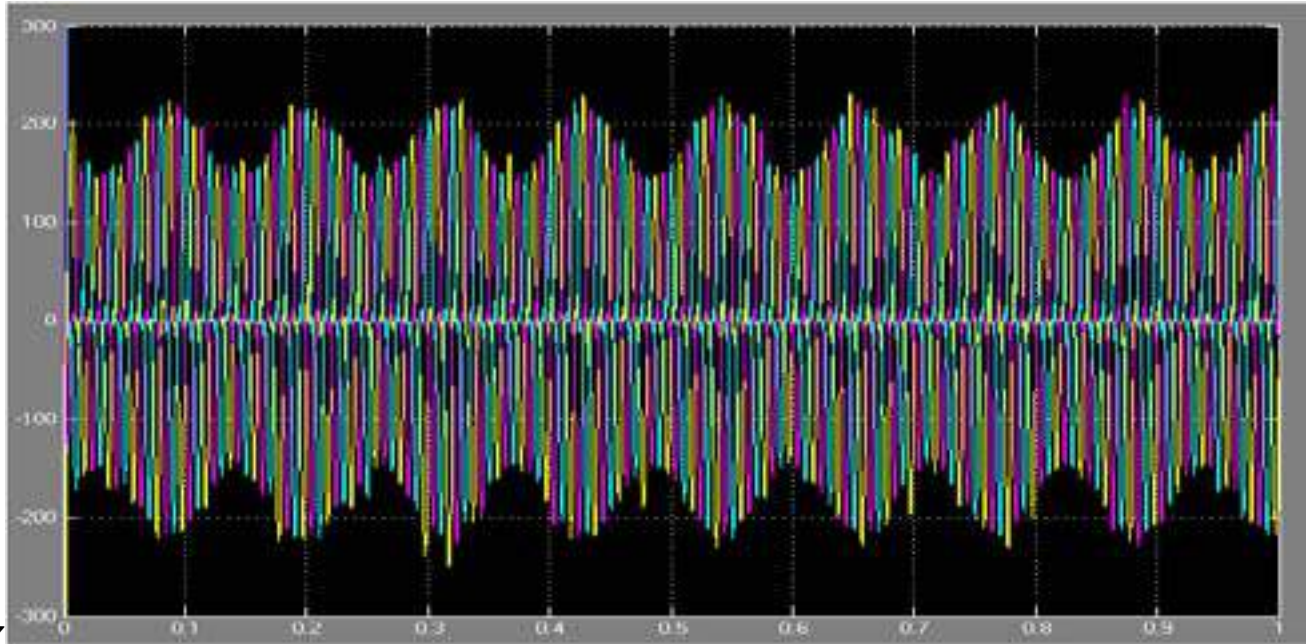

Figure 25: Figure 25 :Figure 27 :

1

*[Note: © 2018 Global Journals]*

Figure 26: Table 1 :



- 
- 206 [Varadan et al. (1996)] ‘A new time domain voltage source model for an arc furnace using EMTP’. S Varadan ,  
 207 E B Makram , A A Girgis . *IEEE Trans. on Power Del* July 1996. 11 (3) p. .
- 208 [Zheng et al. ()] *Effect of Different Arc Furnace Models on Voltage Distortion*, Tongxin Zheng , B Elham , Adly  
 209 A Makram , Girgis . 1998. IEEE.
- 210 [Maontanari et al. ()] *Flicker and distortion compensation in electrical plants supplying arc furnace*, G C  
 211 Maontanari , M Loggini , A Carallini , L Pitti . 1994. IEEE.
- 212 [Golkar and Meschi (2008)] ‘MATLAB modeling of arc furnace for flicker study’. M A Golkar , S Meschi . *IEEE*  
 213 *International Conference on Industrial Technology*, 2008. ICIT 2008. , 21-24 April 2008. p. .
- 214 [Anuradha et al. ()] *Modeling of Electric Arc Furnace & Control Algorithms for voltage flicker mitigation using*  
 215 *DSTATCOM*, K Anuradha , B P Muni , A D Kumar . 2009. p. .
- 216 [Modeling of three phase electric arc furnace” by Manuela panoiu, caiuspanoiu and ionasora ACTA ELECTROTECHNICA ()]  
 217 ‘Modeling of three phase electric arc furnace” by Manuela panoiu, caiuspanoiu and ionasora’. *ACTA*  
 218 *ELECTROTECHNICA* 2007. 48 (2) .
- 219 [Tomasovic ´ Teklic ´ and Filipovic-Gr ´ Ci ? C ´ ()] ‘Modelling of three-phase electric arc furnace for estimation  
 220 of voltage flicker in power transmission network’. Ana Tomasovic ´ Teklic ´ , Bozidar Filipovic-Gr ´ Ci ? C ´ ,  
 221 Ivicapavic ´ . *Electric Power Systems Research* 2017. 146 p. .
- 222 [Sharmeela et al. ()] *Voltage Flicker Analysis and Mitigation Case Study in an Electric Arc Furnace Using*  
 223 *PSCAD/EMTDC*, C Sharmeela , G Uma , M R Mohan , K Karthikeyan . 2004. IEEE. (international  
 224 conference on power system technology)