

Non-Blind DWT-SVD based Watermarking Technique for RGB Image

Md. Atiqur Rahman¹ and M.M. Fazle Rabbi²

¹ Bangladesh University of Business and Technology

Received: 7 February 2015 Accepted: 3 March 2015 Published: 15 March 2015

Abstract

The security of the multimedia file is one of the central concerns in this era of online trade and communication. This paper proposes an algorithm for the robustness of authenticity of digital image against various attacks through embedding and extracting watermarking into image. Using DWT-SVD technique, the RGB colors are separated from both cover and watermark image. For watermarking process, a threshold values from R planes of the watermark image is integrated into R channel of the cover image. The experimental result shows that this method has better robustness against known attacks.

Index terms— watermarking, DWT-SVD, image embedding, image extraction.

1 Introduction

Digital watermarking technology has taken an important position in the industries where copyright, identification, protection and authenticity of a digital content are crucial and priority. Subsequently it has drawn attention to the researchers for developing and improving various techniques of using watermarking in different applications. In a traditional watermarking the watermark is intended to be visible due to identifying the manufacturing company. In contrast to traditional one, the digital watermarking is intended to be imperceptible in the noise tolerant signal of image, audio and video file in such way that the host data does not distort. The multimedia data on the internet has been integrated in the global economy in such a way that it become subject to attack with various readily available tools found in the internet. As a result the watermark in the data requires resistance against various attacks. Watermarking need to be within an acceptable limit and robust when different types of processing is applied in digital content namely adding noise, cropping, compression, resizing [1]. Some attacks are considered as the state-of-the art watermarking attacks which are geometric attacks, cryptographic attacks, removal attacks, protocol attacks and removal attacks [2]. There are mainly two general methods for watermarking which are commonly known as spatial domain technique and frequency domain technique. In the spatial domain approach the information is embedded by altering the pixel value of the cover image. On the other hand the frequency domain method uses the technique of domain transformation. The later one is more robust than the former one. In this method several transformation techniques is available such as Discrete Cosine Transformation (DCT), Discrete Fourier Transformation (DFT) and Discrete Wavelet Transformation (DWT). The obtained frequency component is then modified to hide the watermark. The RGB, YIQ and YUV color space are used for embedding watermark in an host image. The Discrete Wavelet Transformation (DWT) function is combined with the Singular Value Decomposition (SVD) for embedding the watermark in the YUV color space. The RGB color space can be converted into YUV color space and the watermark is embedded into its channels [3]. In the proposed method, the R planes of the watermark is converted using thresholds. Then combined with SVD and DWT to embed data in frequency domain of cover image. The review of related works is given in section II. In section III proposed algorithm is given. The result and analysis of the proposed result is given in section IV.

42 **2 II.**

43 **3 Review of Related Works**

44 Some researchers have used DCT, DWT and SVD technique on the R, G and B components of a host and
 45 watermark image. The watermarking technique used with SVD overcomes the weakness that was found in other
 46 methods [4]. The technique of converting the RGB color components first into the YIQ color component and
 47 then embedding the watermark image into Y and Q color space is shown by Sun and Yu [5]. Gunjal and Mali
 48 proposed embedding watermark in all YIQ, RGB and YUV color channels [6].

49 **4 III.**

50 **5 Proposed Method a) Algorithm for Embedding process**

51 Step 1: The R, G and B planes of host image and watermark image are separated first. Then the R plane is used
 52 for embedding.

53 **6 b) Extraction Process**

54 The watermark and the cover picture are extracted applying the reverse process on the watermarked image. The
 55 extraction procedure is described below:

56 Step 1: Separate R wmi , G wmi and B wmi planes from the watermarked image.

57 Step 2: Decompose R wmi planes four times to receive W LL3 band.

58 Step 3: Apply SVD on W LL3 band and perform the equation $S EWM = S WMI -S ORI$ to receive watermark.
 59 The SEWM is the extracted watermark. SWMI has come from watermarked image and SORI from cover image.

60 Step 4: Apply inversed SVD, inversed DWT and threshold technique to re-construct the watermark image.
 61 The extraction formula is exposed through the figure ??.

62 Step 5: Normalized Correlation is calculated between watermark and extracted watermark image using the
 63 following equation: (2) Where W is Watermark image and EW is extracted watermark image. Fig. ?? Step 6:

64 Pick signal to noise ratio is calculated using the following equation:(3) (4)

65 Where Wmi is Watermarked image and A is attacked image.

66 **7 IV.**

67 **8 Experiment result**

68 In our experiment we have used a watermark to embed into a cover image to construct the watermarked image.
 69 Figure ??? shows the watermarked image derived with Cover image and watermark image. The performance of
 70 the proposed algorithm is measured through the obtained values. The peak signal to noise ratio (PSNR) and
 71 normalized correlation (NC) are used as the performance criteria.

72 The table-1 describes PSNR values between watermarked image and attacked image. It also demonstrates the
 73 NC values of original watermark and the extracted watermark from attacked image.

74 The PNSR value shows the intensity of noise added on the watermarked image through different types of noise
 75 attacks. The lower is PSNR, the higher is the noise added in watermarked image. The higher is normalized
 76 correlation (NC) the better is the similarity between original and extracted watermark image. From the statistic
 77 of the tables it shows that some of the attacks like Sobel, Prewitt, Log, Laplacian, Cropping and Gaussian High
 78 pass add higher noise values in the watermarked image, though the extracted watermark from it produce higher
 79 NC values. The higher NC values mean the better perceptibility of extracted watermark image. The NC values
 80 of this table indicate that the proposed algorithm in this paper is more robust against the above mentioned
 81 attacks. $NC = \frac{\sum_{i,j} W_{r,i,j} EW_{r,i,j} + W_{g,i,j} EW_{g,i,j} + W_{b,i,j} EW_{b,i,j}}{\sqrt{\sum_{i,j} W_{r,i,j}^2 + W_{g,i,j}^2 + W_{b,i,j}^2} \sqrt{\sum_{i,j} EW_{r,i,j}^2 + EW_{g,i,j}^2 + EW_{b,i,j}^2}}$
 82 $MSSE = \frac{1}{M \times N} \sum_{i,j} (W_{r,i,j} - A_{r,i,j})^2 + (W_{g,i,j} - A_{g,i,j})^2 + (W_{b,i,j} - A_{b,i,j})^2$
 83 $V = \frac{1}{M \times N} \sum_{i,j} (W_{r,i,j} - A_{r,i,j})^2 + (W_{g,i,j} - A_{g,i,j})^2 + (W_{b,i,j} - A_{b,i,j})^2$

84 The figure-4 demonstrate watermarked image after diverse attacks.

85 V.

86 **9 Conclusion**

87 In this paper we have proposed an algorithm for embedding and extracting digital watermark on color image by
 88 adopting the technique of DWT and SVD. The color components of the host and watermark image are separated
 89 into R, G and B channels separately. Then the value of the watermark image is embedded into R planes. A
 90 reverse system is applied to retrieve the watermark.

91 The experimental results are analyzed with PSNR and NC values. The result shows the robustness of the
 92 algorithm against malicious and unintentional attacks. The implanted method has received a highest PSNR
 93 and NC values which are 8.035 and 0.9924 respectively. This indicate the strength of robustness of the applied
 94 algorithm in this paper.



23112

Figure 1: Step 2 :DStep 3 : 1)Fig. 1 :Fig. 2 :

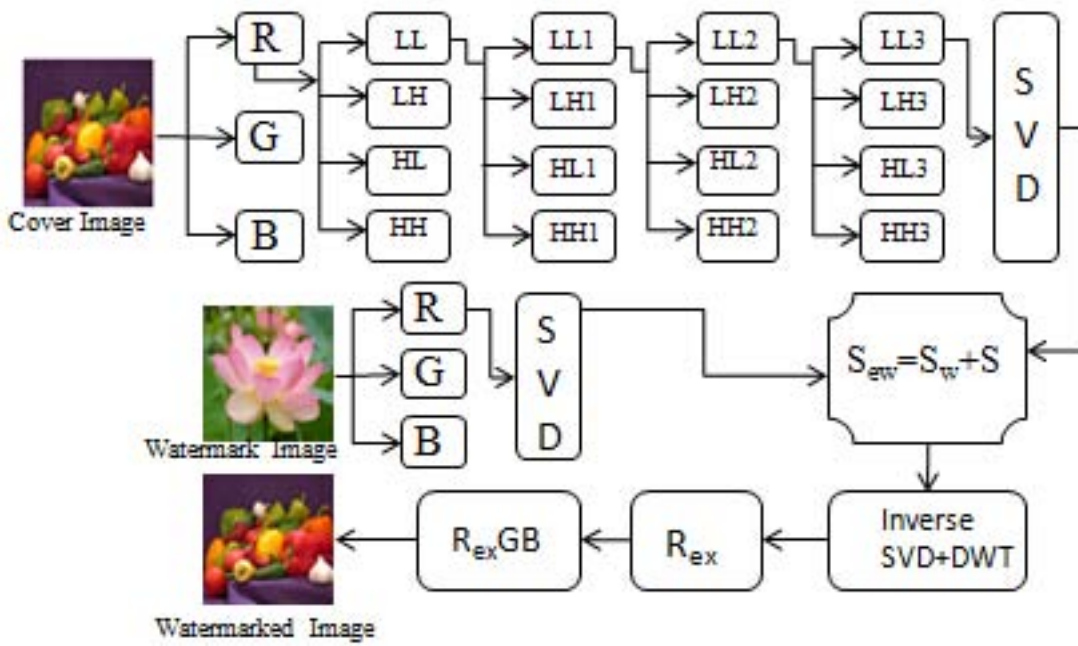
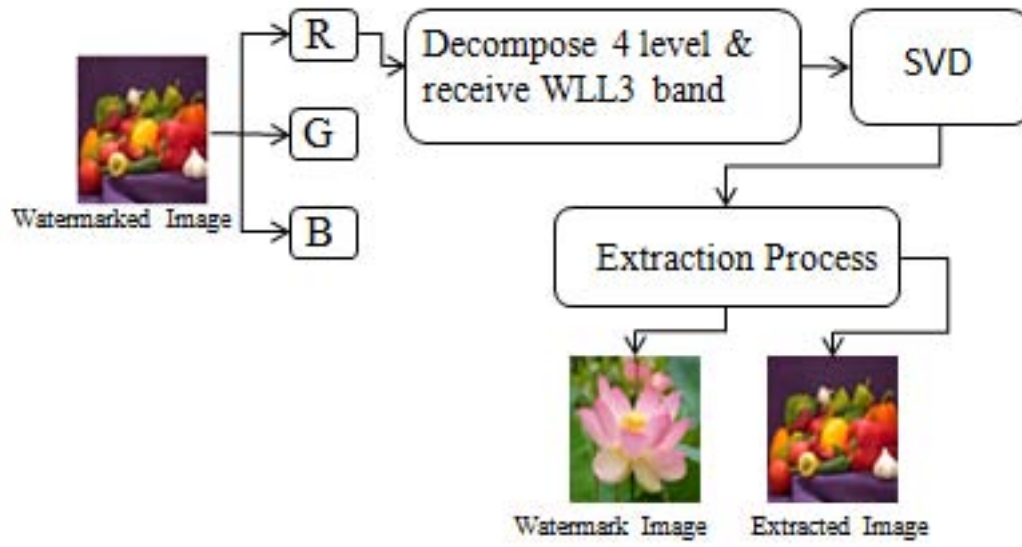

Figure 2: F



4

Figure 3: Fig. 4 :

95 In future experiment we will concentrate on the new technique to improve the perceptibility of the cover image.
96 1

¹Non-Blind DWT-SVD based Watermarking Technique for RGB Image

-
- 97 [Voloshynovskiy et al. ()] ‘Attack modelling: Towards a second generation watermarking benchmark’. S
98 Voloshynovskiy , S Pereira , V Iquise , T Pun . *Signal Processing, Special Issue on Information Theoretic*
99 *Issues in Digital Watermarking* 2001.
- 100 [Gunjal and Mali (2011)] ‘Comparative performance analysis of DWT-SVD based color image watermarking
101 technique in YUV, RGB and YIQ color spaces’. B L Gunjal , S N Mali . *International journal of computer*
102 *theory and engineering* December 2011. 3 (6) .
- 103 [Radharani and Valarmathi ()] ‘Content based Image watermarking scheme using block SVD and Arnold
104 transform’. S Radharani , M Valarmathi . *Electronics and Communication Systems (ICECS)*, 2014.
- 105 [Sun and Yu (2007)] ‘DWT based watermarking algorithm of color images’. G Sun , Y Yu . *Industrial Electronics*
106 *and Applications*, 2007, ICIEA 2007. May 2007. p. .
- 107 [Santhi and Thangavelu ()] ‘DWT-SVD Combined Full Band Robust watermarking technique for color images
108 in YUV color space’. A Santhi , Thangavelu . *International Journal of Computer Theory and Engineering*
109 October2009. 1 (4) p. .
- 110 [Gunjal and Mali ()] ‘Strongly Robust And Highly Secured DWTSVD Based Color Image Watermarking:
111 Embedding Data In All Y,U,V Color Spaces’. B Gunjal , S Mali . *I.J. Information Technology and Computer*
112 *Science* 2012.