

Performance Analysis of MIMO Spatial Multiplexing using different Antenna Configurations and Modulation Techniques in AWGN Channel

Hardeep Singh¹ and Lavish Kansal²

¹ Lovely professional university jalandhar

Received: 8 December 2013 Accepted: 3 January 2014 Published: 15 January 2014

Abstract

Spatial Multiplexing (SM), which employs multiple antennas at transmitter as well as at receiving side, is mainly responsible for the spectral efficiency enhancement in MIMO (Multiple Input Multiple Output) systems without additional bandwidth and power requirement. In this paper, MIMO Spatial Multiplexing technique is analyzed for different antenna configurations (2×2 , 3×3 , 4×4) in AWGN (Additive White Gaussian Noise) channel using higher order modulation techniques (M-PSK, M-QAM). The Zero Forcing detector is employed at the receiving end. The performance of MIMO SM technique is compared for different antenna configurations and simulated results shows that 0-2 db increment in SNR (Signal to Noise ratio) is required if antenna configuration is changed from 2×2 to 3×3 and 0-3 db increment in SNR is required if antenna configurations are changed from 3×3 to 4×4 .

Index terms— multiple input multiple output (MIMO), spatial multiplexing (SM), additive white gaussian noise (AWGN), zero- forcing (ZF), bit error rate (BER).

1 Introduction

ext generation wireless systems will require high data rates and better spectral efficiencies due to multimedia applications. So MIMO (Multiple Input Multiple Output) systems are the key solution to this problem which employs multiple antennas at the transmitter as well as at the receiving side [1]. In order to design MIMO systems we have to study the performance limits of MIMO systems in various channels for better QOS (quality of service) or high spectral efficiencies. V-BLAST (Vertical-Bell Laboratories Layered Space Time) architecture is the first practical implementation of MIMO systems which has attained the spectral efficiency of 40bits/s/Hz [2]. V-BLAST architecture is simple and easy to implement in which the data streams are de-multiplexed into 'n' independent data Streams at the transmitter side and these 'n' independent streams are transmitted in parallel from 'n' independent transmitting antennas. The transmitted streams are received at the receiver and these streams are corrupted by noise [3].

2 Author

: School of Electronics and Communication, Lovely Professional University, Phagwara, Jalandhar, India. e-mails: hardeepbrar8035@hotmail.com, lavish.15911@lpu.co.in so various equalizers are used at the receiving side to combat inter symbol interference. Zero Forcing equalizer is used for this purpose and it is easy to implement and offers less computational complexity at the cost of noise enhancement [4]. Consider a MIMO system with two transmit antenna and two receiving antenna shown in Fig. 1. $Y = HX + N$ (1)

Equation 1 is the MIMO system representation if 'Z' is the no of transmitting antenna and 'M' is the no of receiving antenna ,then Y is the received vector of ' $M \times 1$ ' dimension , H is the channel matrix of ' $Z \times M$ ' dimension, X is the transmit vector of ' $Z \times 1$ ' dimension and N is the noise vector of ' $M \times 1$ ' dimension.

MIMO systems offers 3 advantages Beam forming, Spatial Multiplexing, Spatial Diversity based on Space time coding. The Space time coding jointly encodes the data streams, which leads to reduction in symbol error rate due to channel fading. The space time coding improves the diversity gain and at the same time improves the communication links. Higher order modulations can be applied to attain high data rates along with diversity gain in case of space time coding [5].

In this paper, the MIMO Spatial Multiplexing technique is analyzed for different antenna configurations and different modulation techniques in AWGN (Additive White Gaussian Noise) channel. The

3 II. MIMO SPATIAL MULTIPLEXING

Spatial Multiplexing is a technique which is responsible for increment in spectral efficiency of MIMO systems by transmitting independent streams from independent antennas [6]. The data stream at the input of a transmitter section is divided into 'n' independent data streams and these 'n' independent data streams are transmitted from 'n' independent antennas. The signal from 'n' independent antennas will follow different paths to reach the receiver and these streams will arrive at the receiver at the same time. The different spatial dimensions of the channel are utilized to carry different data streams. Each of these paths will have different spatial signatures at the receiving antenna. The receiving antenna makes use of these spatial signatures to differentiate b/w symbols transmitted from different transmitting antenna. Thus the capacity gain of MIMO channel is increased by 'N' times, where N is the no of transmitting antennas. The MIMO spatial multiplexing system employing 2 transmit antenna and two receiving antenna is described by Fig. 2. The data streams corrupted by noise interfere with each other at the receiving antenna side, so we need equalizer to mitigate inter symbol interference. For this purpose two types of equalizers can be employed at the receiving side one is linear and another is non linear. Linear receivers are used in majority of cases due to their low computational complexity and implementation is also easy. Zero Forcing and Minimum Mean Square Error (MMSE) equalizers are kind of linear equalizers. Maximum likelihood comes in the category of non linear equalizers which is optimal but offers high computational complexity [7]. For Spatial Multiplexing the no of receiving antenna must be greater than or equal to the no of transmitting antenna. The different data streams are sent in the same frequency domain and with the same transmission power from different transmitting antenna as all the data streams follow different paths to reach the receiver [8]. The maximum spatial streams are limited to minimum no of transmit and receive antennas. Spatial Multiplexing can be implemented with or without channel knowledge [9].

4 III.

5 Modulation Techniques

The mapping of incoming digital bits onto the analog carrier is known as modulation. As most channels in the environment support pass band communication, so signals at the transmitter side is modulated with pass band carrier, so that it can be sent in the pass band spectrum. The various parameters of carrier wave are changed to convey information such as amplitude, frequency or phase. The antenna height is proportional to the wavelength of operation, so if we operate at pass band frequencies, antennas of smaller heights has to be installed. With the help of modulation schemes the various signals can be multiplexed and can be sent over the same channel and at the same time. At the receiver side inverse operation is performed, which is known as demodulation, in which the transmitted information is recovered.

6 a) Phase Shift Keying (M-PSK)

In Phase Shift Keying the information is represented by changing the phase of a modulating waveform. The amplitude of M-PSK modulated signal waveform remains constant thereby yielding a circular constellation [10]. The M-PSK modulated signal $s(t) = A \cos(2\pi f_c t + \theta_i)$ is represented as: $s(t) = A \cos(2\pi f_c t + \theta_i)$ where A is the signal energy, f_c is the symbol duration, θ_i is the carrier frequency and 'M' possible signal waveforms. The carrier phase θ_i will have M possible value which is given by: $\theta_i = 2\pi(i-1)/M$

Where A is the signal energy, f_c is the symbol duration, θ_i is the carrier frequency and 'M' possible signal waveforms. The carrier phase θ_i will have M possible value which is given by: $\theta_i = 2\pi(i-1)/M$

Signal space diagram for 8-PSK is given by Fig. 3. In QAM two carriers, which are 90° out of phase are used to encode the incoming digital bits. Both amplitude and phase variations are used to represent the information. In 16-QAM four in-phase and four quadrature values are used which results in 16 possible states for the signal. The QAM modulation is more spectrally efficient as compared to BPSK, QPSK, as symbol rate for QAM is $1/4$ of the bit rate [11]. The QAM modulated signal $s(t) = I \cos(2\pi f_c t) + Q \sin(2\pi f_c t)$ is represented as:

7 Global Journal of Researches in Engineering ()

$s(t) = I \cos(2\pi f_c t) + Q \sin(2\pi f_c t)$ (4)

Where I and Q are amplitudes values and f_c is the carrier frequency. $I = \pm A, \pm 3A, \pm 5A, \pm 7A$ (5)

Where 'M' is mostly taken as power of 4 and it represents the possible waveforms. The signal energy E_s can be related to parameter a as: $E_s = 2a^2$ (6)

8 Channels

The digital bit stream is conveyed from transmitter to receiver via channel which may be a wired connection or wireless link such as radio channel. The characteristics of transmitted signal vary as they travel from transmitting side to receiving side via channel. The convolution of the transmitted signal with the impulse response of channel will give the power profile of the received signal [12]. In this paper the main focus will be on performance analysis of MIMO SM scheme using different antenna configuration and different modulation techniques in AWGN channel.

9 a) AWGN Channel

In AWGN channel, the communication process will have the addition of white noise, whose power spectral density is flat for all the frequencies and its amplitude is Gaussian distributed. The signal will not undergo any kind of fading or frequency selectivity process. The AWGN channel model is presented by Fig. 4. The received signal $y(t)$ can be modelled as: $y(t) = x(t) + n(t)$ (7)

Where $x(t)$ is the transmitted signal and $n(t)$ is additive white Gaussian noise.

V.

10 Zero Forcing Equalizer

When inter symbol interference dominates noise, then zero forcing equalizer can be used to recover the transmitted streams in case of MIMO SM. This equalizer uses inverse frequency response of channel to perform equalization operation. The estimation of strongest signal is done by cancelling the effect of weakest signal from it. The estimated strongest signal is subtracted from the received signal and it performs calculations on the remaining signal to look for the strongest signal in the remaining transmitted signal [13]. The received signal 'S' in case of MIMO SM (2×2) can be represented as: $S = Hx + n$ (8)

Where 'H' represents the channel matrix, 'x' is the transmitted vector, 'n' is the noise vector. The signal x_1 on first receiving antenna is: $x_1 = [h_{11} \ h_{12}]^{-1} [y_1 \ y_2] - n_1$ (9)

Similarly signal x_2 on second receive antenna is: $x_2 = [h_{21} \ h_{22}]^{-1} [y_1 \ y_2] - n_2$ (10)

Where h_{11} is the fading coefficient from first transmitting antenna to first receive antenna.

h_{12} is the fading coefficient from second transmitting antenna to first receive antenna.

h_{21} is the fading coefficient from first transmitting antenna to second receive antenna.

11 Global Journal of Researches in Engineering

() F Volume XIV Issue V Version 2,2 is the fading coefficient from second transmitting antenna to second receive antenna. 'a1' is the symbol transmitted from first antenna and 'a2' is the symbol transmitted from second antenna, 'n1' is the noise at first receive antenna and 'n2' is the noise at second receive antenna.

The received signal in terms of matrix notation can be represented as: $y = Hx + n$ (11)

The algorithm for ZF equalizer is given by: $x = (H^T H)^{-1} H^T y$ (12)

$(H^T H)^{-1} H^T$ is the weight matrix and 'H' is channel matrix. Before quantization the result of ZF equalizer is given by: $\hat{x} = (H^T H)^{-1} H^T y$ (13)

Where \hat{x} is the estimate of transmitted vector.

VI.

12 Results and Discussion

The performance of MIMO Spatial Multiplexing employing ZF equalizer is compared for different antenna configurations (2×2 , 3×3 , 4×4) under different modulation techniques such as M-ary Phase Shift Keying (M-PSK), M-ary Quadrature Amplitude Modulation (M-QAM) in AWGN channel and results are shown in terms of SNR vs. BER plot. The 2×2 antenna configuration is compared with 3×3 antenna configuration at BER of 10^{-3} and similarly 3×3 antenna configuration is compared with 4×4 antenna configuration at the same BER and improvement in SNR (db) is taken into account. The figures 5(a)-(j) show that if antenna configurations are increased from 2×2 to 3×3 and similarly from 3×3 to 4×4 an increment in SNR (db) is required to achieve same amount of BER. The figures 6(a)-(e) shows the performance analysis of MIMO SM technique when M-QAM modulation scheme are employed. By comparing the results in table 1 and table 2 we can easily we can easily figure out that a small amount of SNR is required to achieve same amount of BER if M-PSK modulation schemes are employed as compared to M-QAM modulation schemes in case of MIMO SM technique. a) Simulations using M-PSK scheme

13 Conclusion

In this paper, the performance of MIMO SM technique employing ZF equalizer in AWGN channel is presented for different antenna configurations (2×2 , 3×3 , 4×4) using higher order modulation schemes (M-PSK, M-QAM). As we go on increasing the antenna configurations from 2×2 to 3×3 an increment of 1 to Global Journal of

13 CONCLUSION

154 Researches in Engineering () F Volume XIV Issue V Version I 2.5db in SNR has to be made to achieve same
155 amount of BER of 10^{-3} . Thus the spectral efficiency gets doubled in case of MIMO SM technique at the
156 expense of small amount of increment in SNR (0 to 4db) ,that has to be made in AWGN channel when higher
order modulation (M-PSK,M-QAM) schemes are employed. ¹



Figure 1: Figure 1 :

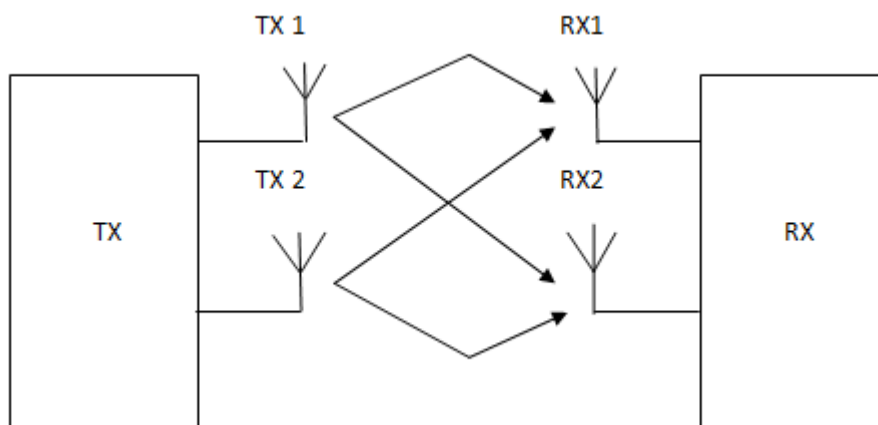

Figure 2:

157

2

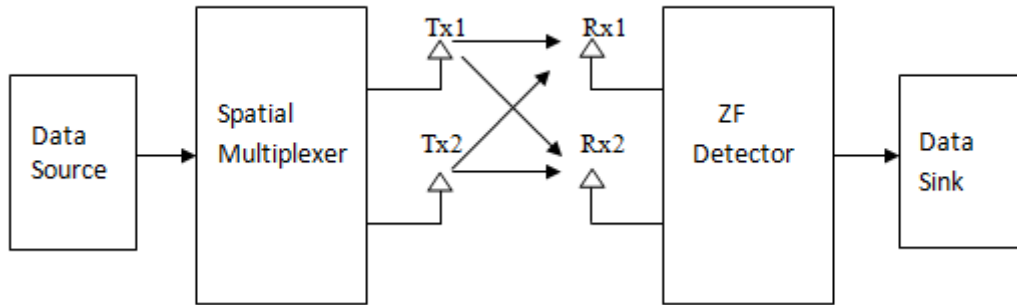

Figure 3: Figure 2 :

3

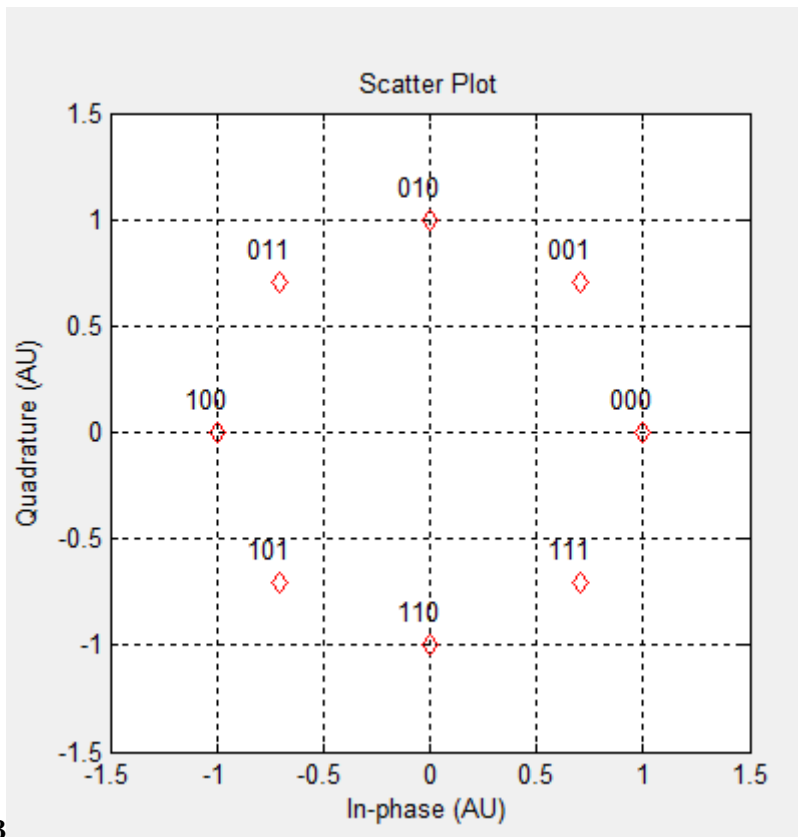
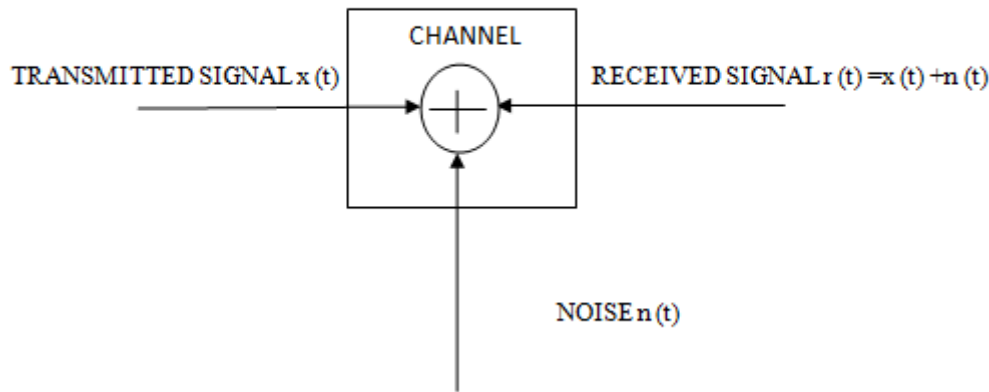

Figure 4: Figure 3 :



4

Figure 5: Figure 4 :

1

channel using M-PSK (M-ary Phase Shift Keying) modulation schemes

Modulation	2×2	3×3	Improvement In SNR	4×4	Improvement In SNR
BPSK	29.7	31.5	1.8	33.2	1.7
QPSK	36.1	37.7	1.2	38.5	1.2
8-PSK	41.4	42.6	1.2	43.9	1.3
16-PSK	47.4	49.2	1.8	50.3	1.1
32-PSK	52.9	55.2	2.3	56.8	1.6
64-PSK	59.2	61.5	2.3	62.9	1.4
128-PSK	64.9	66.2	1.3	68.6	2.4
256-PSK	71.7	73.2	1.5	74.2	1.0
512-PSK	77.5	79.1	1.6	79.9	0.8
1024-PSK	83.3	85.0	1.7	85.8	0.8

Table 1 presents that MIMO SM technique requires 1 to 2.5db increment in SNR to achieve the BER of 10^{-3} , if antenna configurations are changed from 2×2 to 3×3 when M-ary Phase Shift Keying (M-PSK) modulation scheme is employed. The table also points that if antenna configurations are changed from 3×3 to 4×4, an increment of .7 to 2.5db SNR has to be provided to achieve BER of 10^{-3} . Table 1 also states that the spectral efficiency gets doubled in case of MIMO SM technique if antenna configurations are changed from 2×2 to 4×4, at the cost of 1 to 4db increment in SNR.

b) Simulations using M-QAM s

Figure 6: Table 1 :

2

channel using M-QAM (M-ary Quadrature Amplitude Modulation) modulation scheme

Modulation	2×2	3×3	Improvement In SNR	4×4	Improvement In SNR
QAM	35.9	37.4	1.5	38.5	1.1
16-QAM	43.8	45.6	1.8	46.9	1.3
64-QAM	50.9	52.5	1.6	53.4	0.9
256-QAM	57.4	58.6	1.2	59.5	0.9
1024-QAM	63.3	65.2	1.9	67.6	2.4

Figure 7: Table 2 :

2

VII.

Figure 8: Table 2

-
- 158 [Global Journal of Researches in Engineering] , *Global Journal of Researches in Engineering*
- 159 [Zhang and Niu (2004)] ‘Adaptive transmission in spatial multiplexing system with zero forcing receiver’. K
160 Zhang , Z Niu . *th International Symposium on Multi-Dimensional Mobile Communications*, September
161 2004. 1 p. .
- 162 [Vadehra ()] *BER analysis of 2×2 Spatial Multiplexing under AWGN and Rayleigh channels for different*
163 *Modulations*, A Vadehra , L . 2013. 13 p. .
- 164 [Vadehra ()] ‘BER analysis of 3×3 MIMO Spatial Multiplexing under AWGN & Rician channels for Different
165 Modulation Techniques’. A Vadehra , L . *International Journal of Computer Science* 2013. 10 (1) p. .
- 166 [Gupta and Grover ()] ‘BER Performance Analysis of MIMO systems using Equalization Techniques’. R Gupta
167 , A Grover . *Journal of Innovative Systems Design and Engineering* 2012. 3 (3) p. .
- 168 [Vidya and Kumar (2013)] ‘BER Performance of AWGN, Rayleigh and Rician channel’. K Vidya , K R S Kumar
169 . *International Journal of Advanced Research in Computer and Communication Engineering* May 2013. 2 (5)
170 p. .
- 171 [Moon et al. (2010)] ‘Enhanced Groupwise Detection with a New Receiver Combiner for Spatial Multiplexing
172 MIMO Systems’. S H Moon , J Jeong , H Lee , I Lee . *IEEE Transactions on Communications* September
173 2010. 58 (9) p. .
- 174 [Babu and Rao (2011)] ‘Evaluation of BER for AWGN, Rayleigh, Rician Fading channels under various Modu-
175 lation Schemes’. A S Babu , K V S Rao . *International Journal of Computer Application* July 2011. 26 (9) p.
176 .
- 177 [Wang et al. (2007)] ‘On the Performance of the MIMO Zero Forcing Receiver in the presence of Channel
178 Estimation Error’. C Wang , E K S Au , R D Murch , W H Mow . *IEEE Transactions on Wireless*
179 *Communications* March 2007. 6 (3) p. .
- 180 [Kostina and Loyka ()] ‘Optimum Power and Rate Allocation for Coded V-BLAST: Average Optimization’. V
181 Kostina , S Loyka . *IEEE Transactions on Communications* 2011. 59 (3) p. .
- 182 [Kaur ()] ‘Performance Comparison of MIMO systems over AWGN and Rayleigh channels with Zero Forcing
183 Receivers’. N Kaur , L . *Global Journal of Researches in Engineering* 2013. 13 (1) p. .
- 184 [Sidel and Krzymein ()] ‘Performance evaluation of spatially multiplexed MIMO systems with subset antenna
185 transmission in interference limited environment’. S Sidel , W A Krzymein . *Wireless Personal Communi-*
186 *cation* 2007. 43 (2) p. .
- 187 [Mesleh et al. (2006)] ‘Spatial Modulation-A new Low Complexity Spectral Efficiency Enhancing Technique’. R
188 Mesleh , H Haas , C W Ahn , S Yun . *International Conference on Communications and Networking*, October
189 2006. p. .
- 190 [Wolniansky et al. (1998)] ‘V-BLAST very high data rates over the rich-scattering wireless channel’. P W
191 Wolniansky , G J Foschini , G D Golden , R Valenzuela . *International Symposium on Signals, Systems*
192 *and Electronics*, October 1998. p. .