

CrossRef DOI of original article:

Study on the Influence of UAV Wingtip Connection on Ceiling and Endurance

Wei Zhou¹, Peiyang Ma², Qiuyan Wang³, Xueqian Shi⁴ and Kaixuan Liu⁵

¹ PLA Rocket Force University of Engineering

Received: 1 January 1970 Accepted: 1 January 1970 Published: 1 January 1970

Abstract

The cluster UAVs have developed rapidly in recent years with the advantages of low cost, expandability and high reliability. However, due to their small size, they have the shortages of range and flight time. Wingtip connection technology, as an important way to increase the range and flight time of fixed-wing cluster UAVs, has also developed rapidly in recent years. From the theoretical analysis, it is concluded that the wingtip connection can effectively improve the aerodynamic characteristics of fixed-wing UAVs, and the conclusions are validated by vortex lattice method simulation. Based on this, the influence of the number of units on the flight performance of the combination is analysed theoretically. As the number of units increases, the combination can have higher ceiling, larger range and longer flight time.

Index terms—

1 I. Introduction

With the increasingly complex battlefield environment, the war has put forward higher requirements for the mission capability and viability of UAVs. The cost of large strategic deterrence UAVs continues to rise, and the cluster UAVs have gradually become a new focus [1]. However, due to the cost and volume constraints, cluster UAVs are inherently short of range and endurance. At present, there are three common methods to improve the range and endurance of the aircraft: First, the aerial refuelling technology is adopted, but for a large number of cluster UAVs, the efficiency of aerial refuelling cannot meet the actual needs. The second is to use a large aspect ratio design combined with solar power module, but for clustered UAVs that need high flexibility and mobility, the aspect ratio will be greatly limited, while the small aspect ratio combined with solar power module will have very low income. Third, like the "Gremlins" in the United States, large transport planes are used for long-distance delivery, but this only solves the problem of long distance, not the endurance time.

In recent years, with the rise of clustered UAVs, a technology that once appeared has been re-valued, namely wingtip connection technology. Scientists hope that the fixed-wing cluster UAVs can form a combination with a large aspect ratio through wingtip connection. At this time, if the UAVs combined with solar technology, the range and endurance time can be greatly extended [2].

Wingtip connection was first proposed by Richard Vogt, a German scientist who immigrated to the United States after World War II. Based on this concept, the United States carried out "MX-1018" (Tip-Tow) and "Tom Tom" projects. However, due to the aerodynamic interference at the wingtip, this research has caused great potential safety hazards and even casualties. In addition, the impact of the gradual maturity of aerial refuelling technology at that time temporarily caused the flight test of wingtip connection stop [3].

Since the 21st century, scientists in the United States, Germany and China have seen the great value of wingtip connection, see Figure 1, for it can improve the ceiling and endurance of cluster UAVs, and gradually resumed and accelerated the study on wingtip connection. Through computational fluid dynamics analysis and wind tunnel test, American scientists analysed and studied aerodynamics and aerodynamic control in the process of wingtip connection [4][5][6][7], and verified the flight control system through flight test [8][9][10]; German scientists mainly explored and practiced the wingtip connection technology in engineering [11], and focused

5 III. SIMULATION STUDY ON FLIGHT PERFORMANCE OF WINGTIP CONNECTION

45 on designing the control system of the combination [12] ; Since 2018, China has started the exploration and
46 study of relevant technologies, demonstrated that wingtip connection can improve range and endurance [13,14]
47 , and conducted relevant flight tests [15,16] . In this paper, through the study on the aerodynamic theory of
48 the UAV combination, simulation and example verification are carried out on the improvement of the ceiling
49 and endurance of the wingtip connection, so as to verify that the clustered UAVs can improve the ceiling and
50 endurance by wingtip connection.

51 2 II. Basic Theoretical Research on Flight Performance of 52 Wingtip Connection

53 Taking the conventional aircraft with a wing, without offset, dihedral and twist, as an example, the aerodynamic
54 performance of the combination formed by the wingtip connection of the flying units with identical n frames is
55 analysed theoretically.

56 3 a) Effect of Wingtip Connection on Lift-drag Ratio

57 Lift-drag ratio is the most intuitive embodiment of aircraft aerodynamic performance. The larger the lift-drag
58 ratio, the better the aerodynamic performance. In this section, it is assumed that the external environment
59 before and after wingtip connection is unchanged, and the flight altitude and speed of the aircraft are unchanged.
60 When the flight state is approximately at the minimum resistance, the endurance can reach the maximum. This
61 is an ideal state, which can predict the trend and simplify the formula. For this state, there is always a waste
62 resistance coefficient, C_{D0n} , equal to the induced resistance coefficient, C_{Di} , because the induced resistance
63 is inversely proportional to the square of the velocity, and the waste resistance is proportional to the square of
64 the velocity. When the two are equal, the total resistance is the smallest, see Figure 2, that is The lift-drag ratio,
65 K , can be derived from equations (1) and (2).
66
$$D_n D_n C_A e A K n e C C C ? ? = = ? (3)$$

67 Under the assumptions in this section, the parasitic resistance coefficient of the combination is equal to the
68 coefficient of the flight unit, which is a constant, that is $C_{Dn} = C_{Dn} C C = 0 4 D n A C ? . n n K n e ? (4)$

69 That is, the lift-drag ratio of the assembly K_n is proportional to n . Here, the Oswald efficiency factor can
70 be calculated according to the formula mentioned in literature [2], that is $() 0 1 1 n d e n A k C s ? \mu = + (5)$

71 Where, according to the Oswald efficiency coefficient of the high aspect ratio wing, k is assumed to be 0.18
72 [17], C_{d0} is the resistance coefficient of the airfoil. μ is the theoretical Oswald coefficient without considering the
73 influence of the fuselage, s indicating the influence of the fuselage on the induced resistance, which is a function
74 of the fuselage diameter d and the wingspan b . $?? = -? ? ? ? (6)$

75 For the specified flight unit, in equation (5), all are constants except e_n and n , so it is advisable to set $() 1 0$
76 $2 1 d k A k C k s ? \mu = ? ? = ? (7)$

77 Then equation (5) can be reduced to $1 2 1 n e k n k = + (8)$

78 It can be seen that Oswald efficiency factor decreases with n increasing.

79 4 b) Effect of Wingtip Connection on Cruise Speed

80 This section assumes that the maximum lift-drag ratio point of the flight unit is taken at 0° , so that the cruise
81 speed of the flight unit is the speed of horizontal flight at 0° angle of attack. It is assumed that the force balance of
82 flight units before and after the wingtip connection is always satisfied, and the flight altitude remains unchanged.

83 Define that in the two-dimensional plane, the horizontal flight direction of the aircraft is the x-axis positive
84 direction, and the y-axis is perpendicular to the x-axis and upward. Carry out force analysis on the X and Y
85 directions of the aircraft respectively, and then equation (??) is on X axis, equation (10) is on Y axis.
86 $2 1 2 n n n n L n n G L V C S ? = = (9) 2 1 2 n n n n L n n G L V C S ? = = (10)$

87 It can be seen from equation (??) and (10), $n n n F G K = (11)$

88 That is, when the maximum lift-drag ratio is reached, the cruising pull is the smallest, so that the endurance
89 time is the longest.

90 The lift coefficient calculation formula given by reference [15] under the constant speed assumption.
91 $1 1 = 2 2 2 i i L n n n n n L L L C V V n S S n S ? ? - - - ? ? ? ? ? ? ? ? - ? ? ? ? ? ? ? ? ? ? ? ? (12)$

92 It can be seen that the lift coefficient increases with the increasing of n . Where L_i is the ideal lift of a single
93 wing calculated according to the two-dimensional infinite length model, and $L?$ is the lift difference for one side
94 of a single wing. Under the assumption of this section, when G_n unchanged, V_n gradually decreases with the
95 increase of C_{Ln} , and equation (10) can be reduced to equation (13).
96 $1 n L n V C ? (13)$

That is, the cruising speed of the combination is inversely proportional to $L_n C$.

97 5 III. Simulation Study on Flight Performance of Wingtip 98 Connection

99 The vortex lattice method is used to simulate the aerodynamic performance of the wingtip connection. Under
100 the constant lift mode, the simplified full USA-35b airfoil model of a rectangular wing with 3 m wingspan and

0.4 m chord length is calculated, as shown in Figure 3, assuming that the wingtip is rigidly connected and there is no gap. The mass of the flight unit is 60 kg, when the angle of attack is $\alpha = 0^\circ$ and the torque coefficient $C_m = 0$ at approximately the maximum lift-drag ratio.

The approximate equivalent method of direct size increase is used in the calculation of the combination, which will lead to some errors in the simulation results. This method is used to simulate the changes of lift-drag ratio and flight speed with different number of units. The simulation results of aerodynamic characteristics at an altitude of 2000 m are shown in Figure 4. For the sorted data, and draw Figure 5 for the simulation lift-drag ratio at 0° and the calculated theoretical lift-drag ratio. It can be seen that the law of lift-drag ratio approximately meets n times, and the failure to reach n times is caused by $e_n < 1$. This result is consistent with the conclusion in Section 2.1. Shown in Figure 6, two parameters of lift coefficient and flight speed with different n are extracted from the simulation results. It can be seen that the demand for cruise speed gradually decreases with the increase of n , thus reducing the consumption of power and energy. The relationship between C_L/n^2 and n is shown in Figure 7, verifying equation (13), which is consistent with the conclusion in Section 2.2. In this section, it is assumed that the flight unit or combination will fly at a constant speed and level under the condition of force balance.

When n is constant, both G_n and S_n are constant, too. Then let equation (10) be reduced to $3n/nL_nk = VC = 0.312n/nGLSk = (14)$

It can be seen that G_n , S_n and k_3 remain unchanged when the height changes. Then equation (14) can be reduced to $312n/n/nFDskK = (15)$

That is, when the flight altitude changes, the pull required for the level flight of the combination is only related to the lift-drag ratio, which mainly depends on the flight speed and angle of attack [18], and is not sensitive to the altitude change, so the demand for pull at different altitudes is basically unchanged.

Using the model of Section 3, since the influence of the fuselage is not considered, the induced resistance is used to estimate the resistance of the whole aircraft. The induced resistance of the flight unit is calculated according to the following formula. $2111112iDiDVCS = (16)$

In the formula, the lower corner mark 1 represents the flight unit, and the induced resistance of the flight unit is calculated, $D_{i1} = 14.91N$. The induced resistance of the small fixed wing UAV accounts for 25% ~40% of the total resistance. Here, the waste resistance of the flight unit is calculated according to the induced resistance accounting for 30% of the total resistance, $D_{p1} = 41.74N$. Similarly, the induced resistance of the combination, D_{in} , can be obtained, while the waste resistance of the combination, D_{pn} , can be calculated using the following formula. $n_{pn}pVDnDV = (17)$

Then calculate the tensile demand of a single propeller through the following formula. $in_{pn}nDDFn + = (18)$

The relationship between tensile force F_n and n is shown in Figure 8. It can be seen that the required tension F_n decreases with the increase of n , and the change rate decreases.

When estimating the resistance according to Section 4.1 using the model of section 3, for a motor drive, the 1.5:1 reduction mechanism and 16×8 APC propeller is calculated under 32 V power supply. The maximum pull of single propeller at different altitudes is shown in Table 3, and Figure 9 is drawn accordingly. The fitting formula of the curve is obtained. The relationship between n and the ceiling is shown in Figure 10. It can be seen that increasing the number of flight units can effectively improve the ceiling of the aircraft. The ceiling increases with the increase of n , while the change rate decreases.

Assuming a 128 Ah 32 V power supply is used and the combination flies horizontally at an altitude of 2 km, the working current and flight time of the combination with different n are calculated as shown in Table 5. The relationship between n and flight time is shown in Figure 11.

6 V. Results and Discussion Conclusion

With the rise of cluster UAVs, wingtip connection technology has been paid attention again. Wingtip connection can make the flight unit fly higher, farther and more durable.

Firstly, the theoretical analysis of wingtip connection is carried out, and two conclusions are obtained through the theoretical analysis. First, the lift-drag ratio of the combination K_n is proportional to $n e_n$, and the Oswald efficiency factor e_n decreases with the increase of n ; The second is that the cruise speed of the combination V_n is inversely proportional to $L_n C_L$. Then, the correctness of the above two conclusions is verified by simulation. Based on this, the influence of wingtip connection on endurance performance is analysed, and the following conclusions are obtained. First, the flight altitude has little effect on the tensile demand, but tensile demand decreases with the increase of n , while the change rate decreases; The second is that the ceiling increases with the increase of n , while the rate of change decreases; Third, the endurance time increases with the increase of n , while the change rate decreases. Theoretically, increasing the number of units n can continuously improve the flight performance of aircraft.

7 c) Wingtip Connection can Increase Endurance Time

However, as the number of assembly units increases, the ceiling and endurance benefits brought by connection gradually decrease. In addition, largescale wingtip connections have high requirements for control systems and

7 C) WINGTIP CONNECTION CAN INCREASE ENDURANCE TIME

161 connecting mechanisms. Too many units will lead to more complex control and connecting mechanisms with greater loads. Therefore, the number of wingtip connections is not the more the better.



Figure 1: Figure 1 :

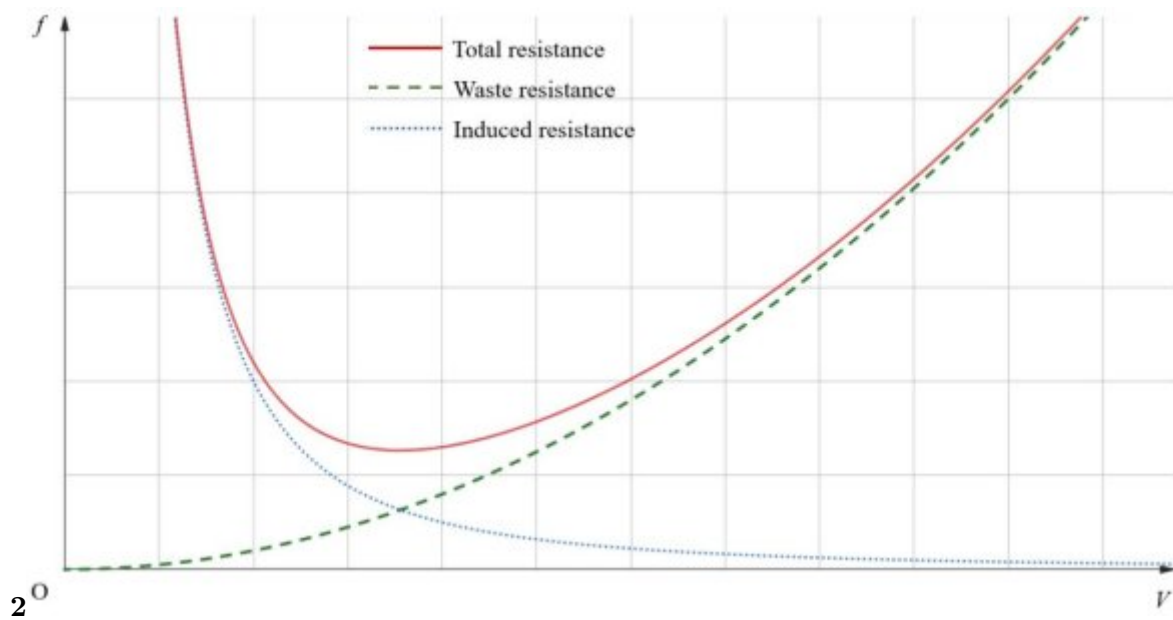

Figure 2: Figure 2 :D

162

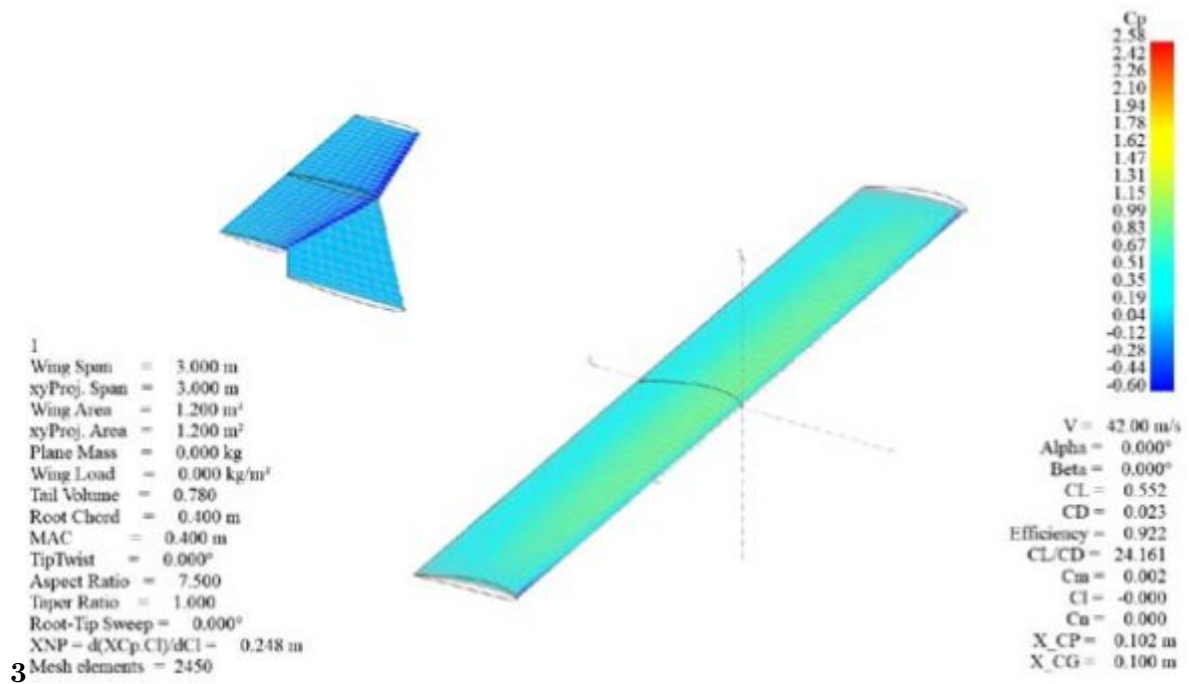

Figure 3: Figure 3 :

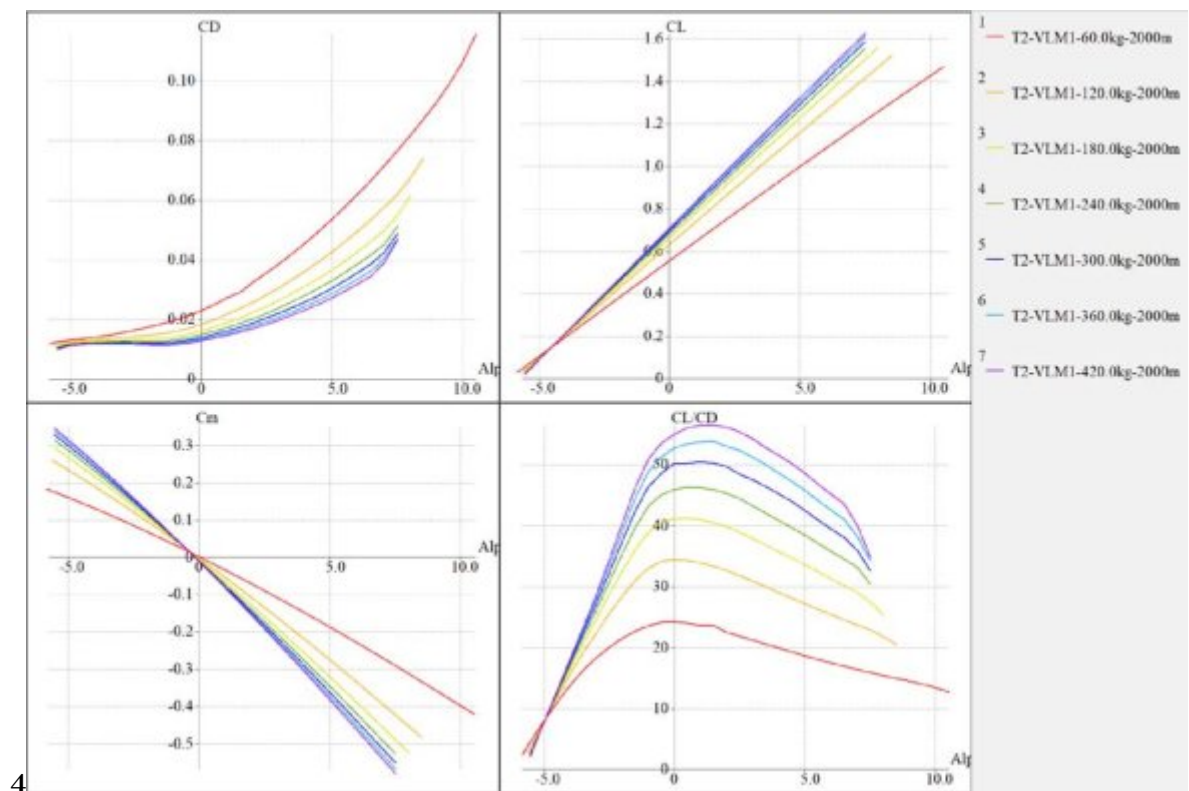

Figure 4: Figure 4 :

7 C) WINGTIP CONNECTION CAN INCREASE ENDURANCE TIME

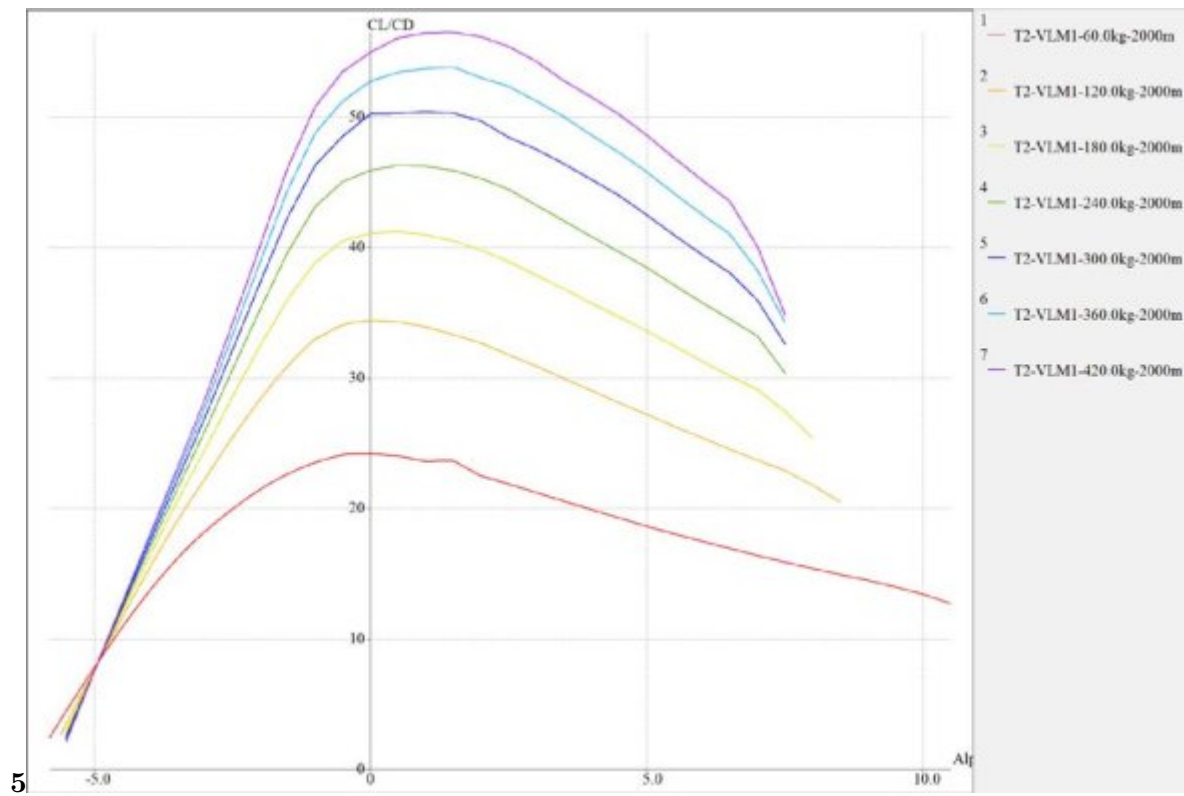

Figure 5: Figure 5 :

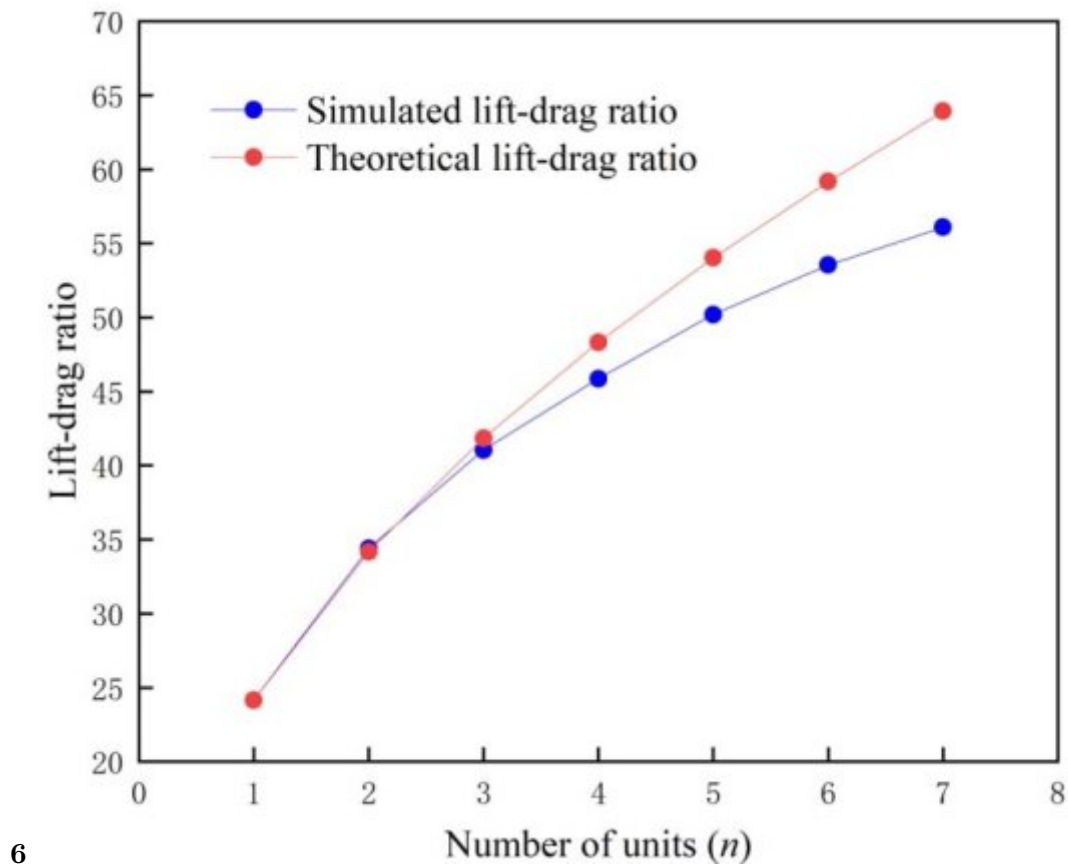
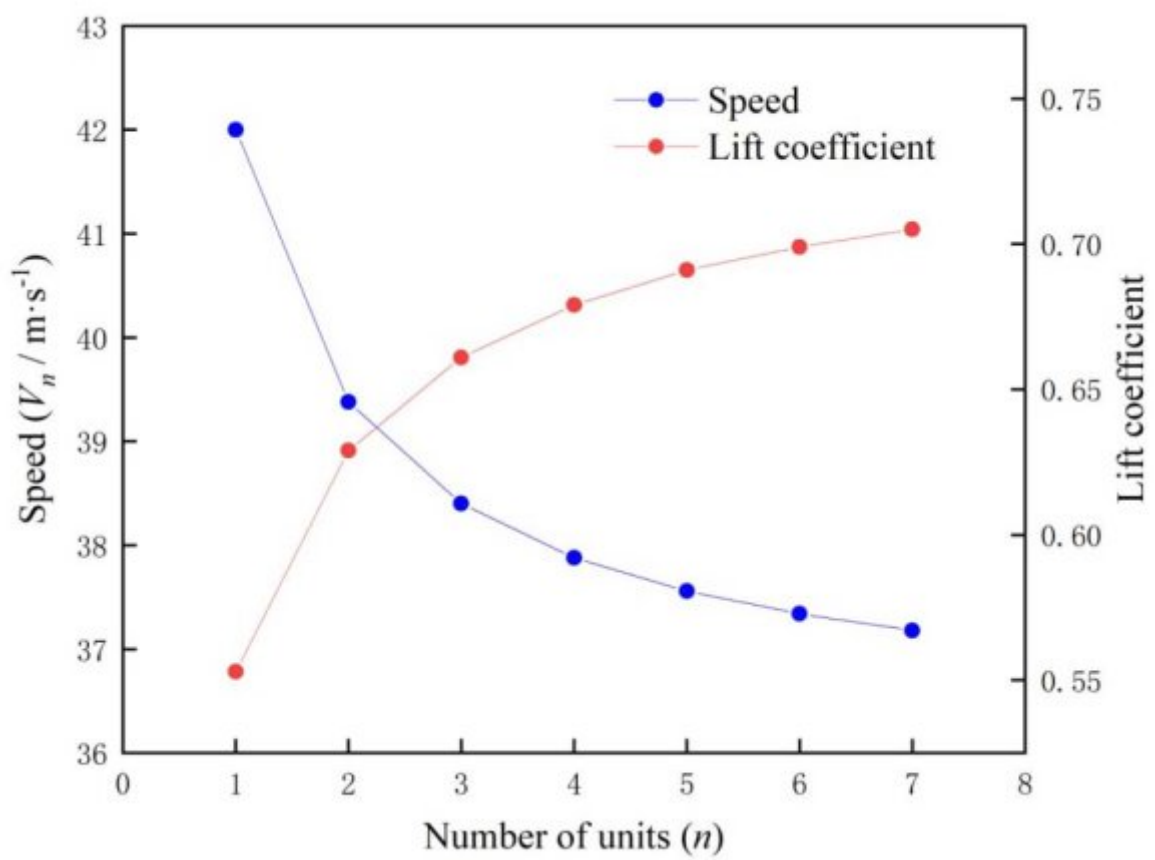
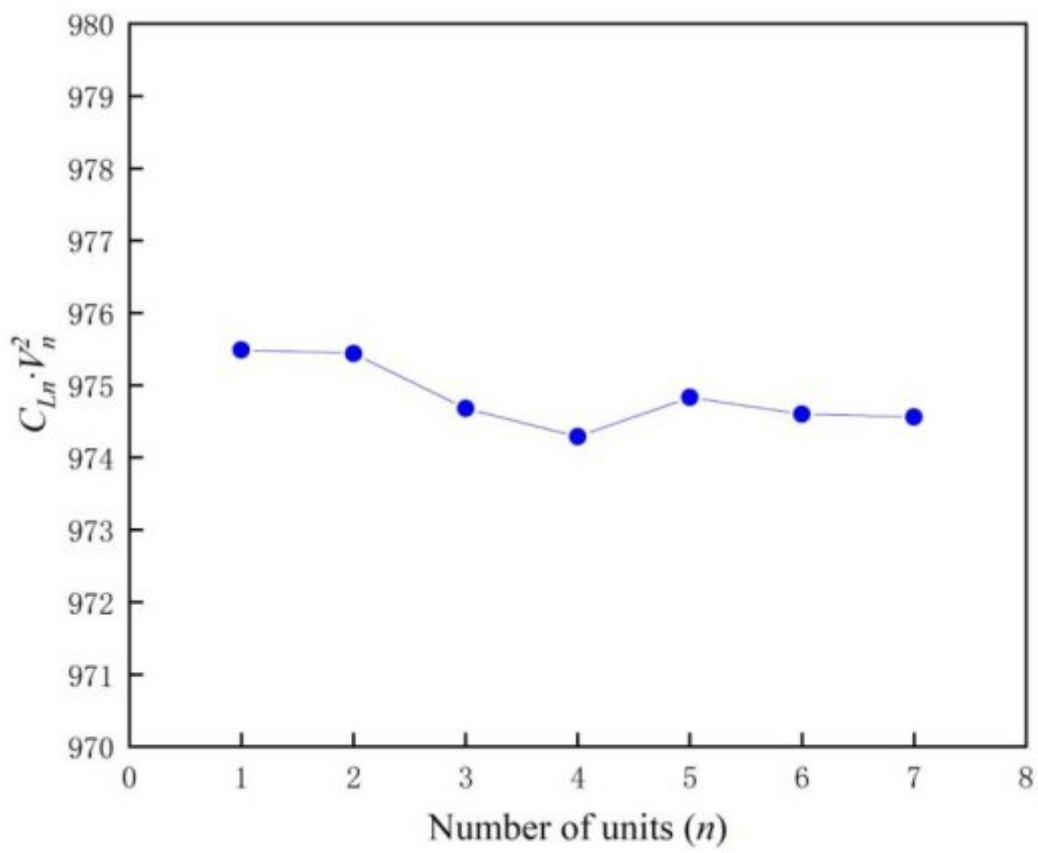

Figure 6: Figure 6 :D



7

Figure 7: Figure 7 :



8

Figure 8: Figure 8 :

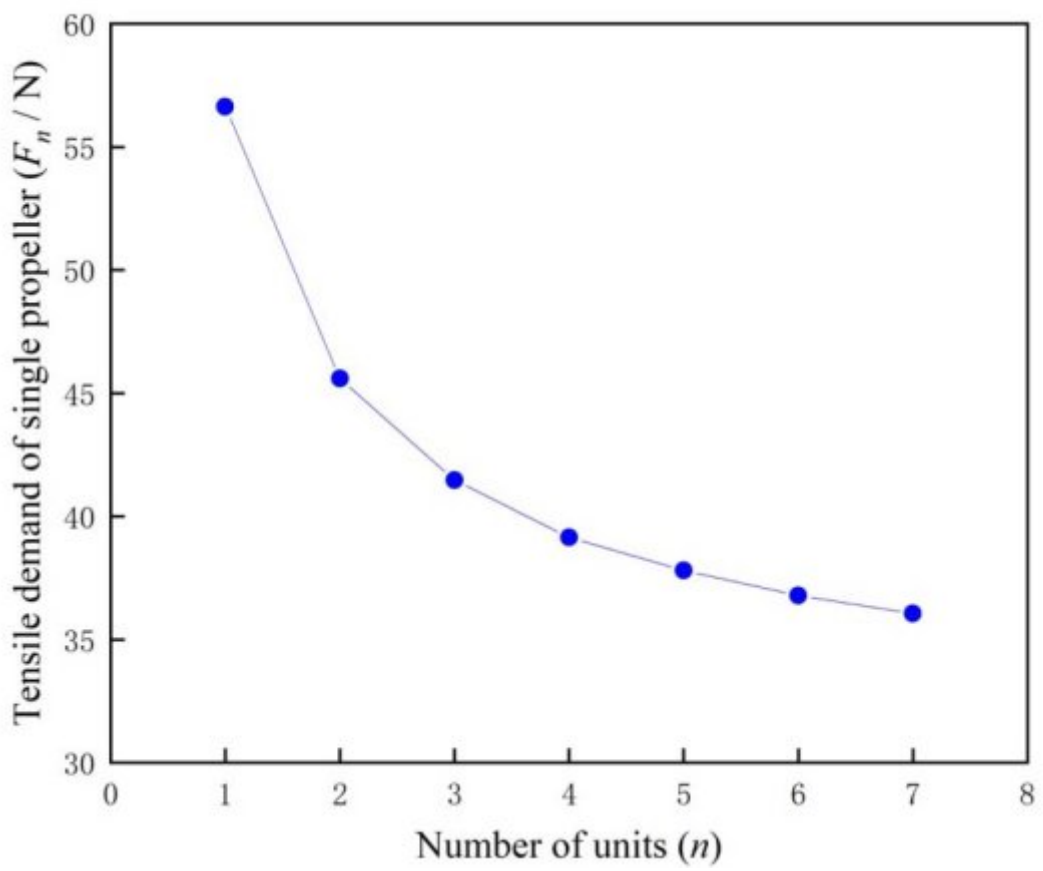

9

Figure 9: Figure 9 :

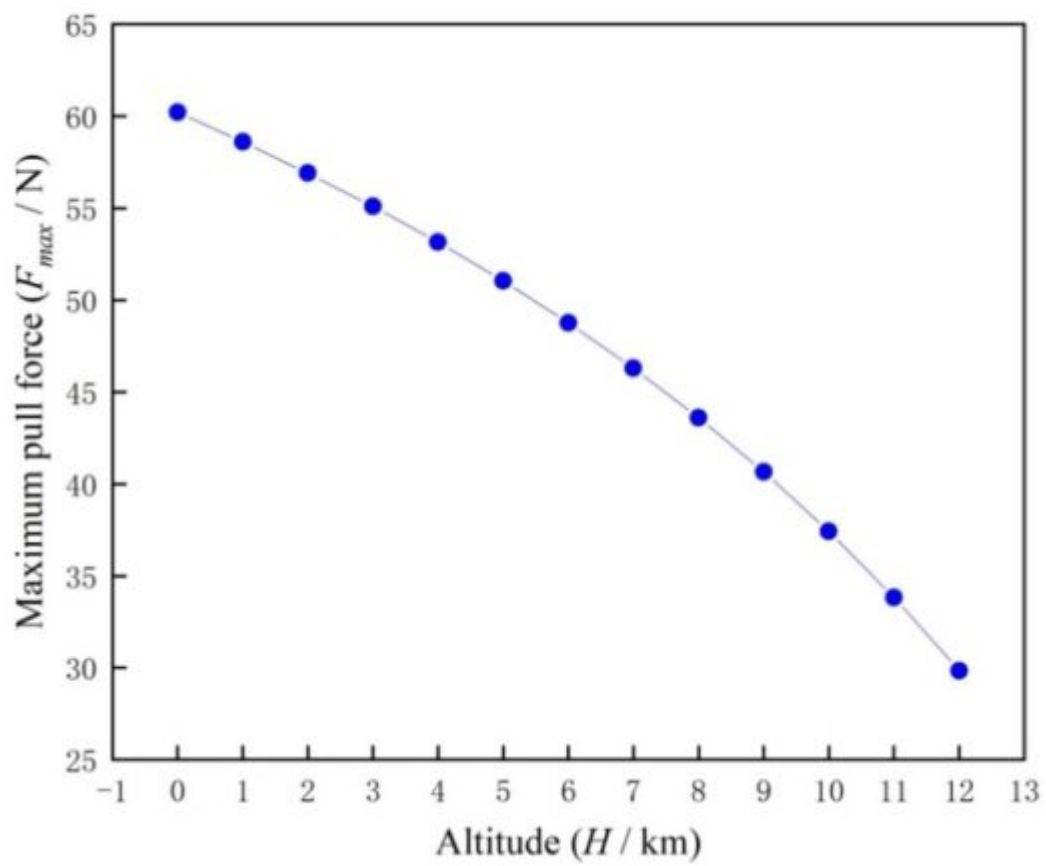

10

Figure 10: Figure 10 :D

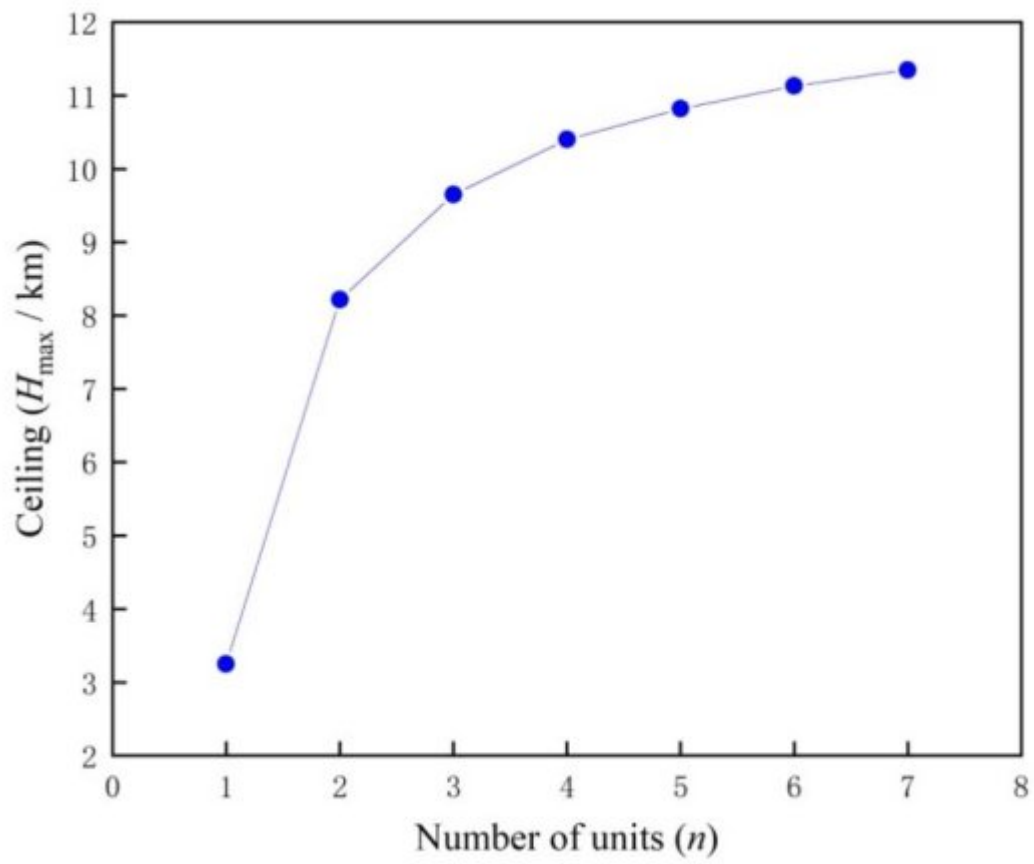

11

Figure 11: Figure 11 :

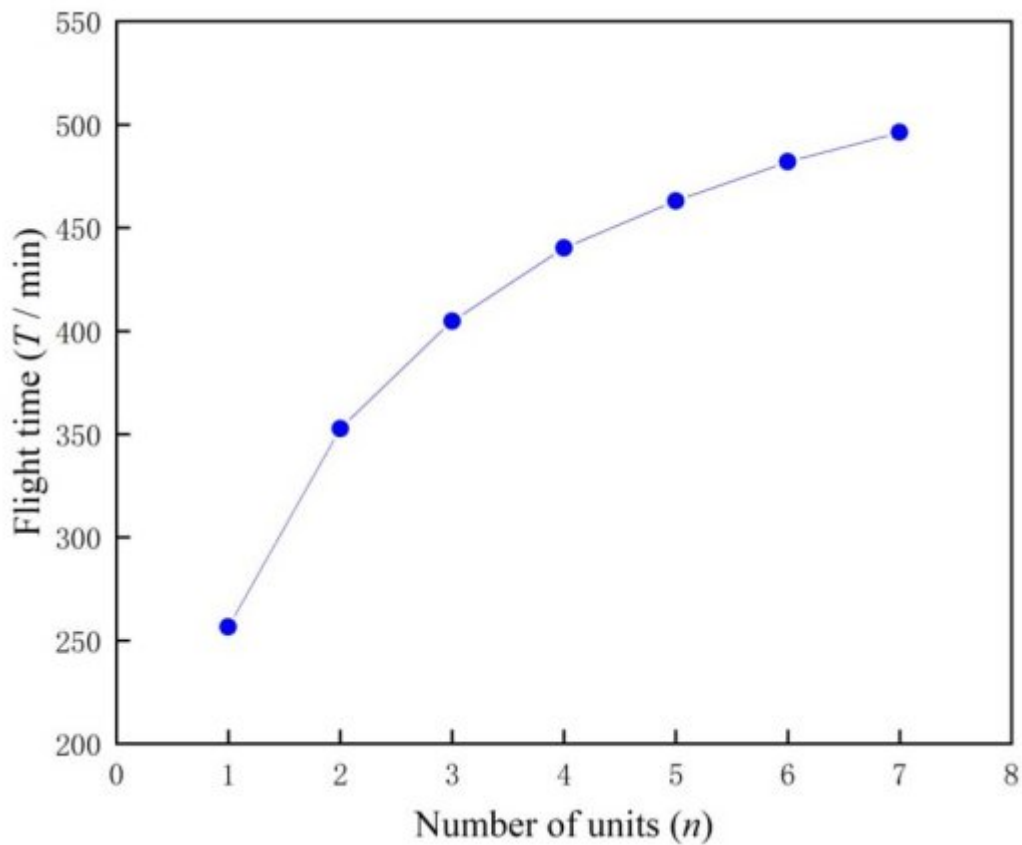

Figure 12:

1

b

n	Simulated lift-drag ratio	Theoretical lift-drag ratio	Speed[m/s]	Lift coefficient	C _L	Ln	?V _n
1	24.161	24.161	42.00	0.553	2	975.49	975.44
2	34.397	41.050	39.38	0.629	2	974.68	974.29
3	41.847	48.322	38.40	0.661	2	974.60	974.56
4	54.024	59.170	37.88	0.679	2	974.83	
5	63.930		37.56	0.691	2		
6			37.34	0.699	2		
7			37.18	0.705	2		

Year 2023
5
Volume Xx XIII
Issue I V ersion
I
()

Global Journal
of Researches in
Engineering

© 2023 Global
Journ als

D Study on the Influence of UAV Wingtip Connection on Ceiling and Endurance

Figure 13: Table 1 :

2

n	Tensile demand of single propeller F _n [N]
1	56.64
2	45.59
3	41.48
4	39.15
5	37.81
6	36.78
7	36.05

Figure 14: Table 2 :

3

Year 2023

8

Volume Xx XIII Issue I Version I

Altitude b) Wingtip Connection can Raise the Ceiling Maximum pulling force Altitude

Global Journal of Researches in Engineering	H[km]						F _{max} [N]		H [km]
	0	1	2	3	4	5	6	7	8
							60.22	58.61	7
							56.91	55.10	10
							53.15	51.05	12
							48.76		

© 2023 Global Journals

Figure 15: Table 3 :

44

$$\max F = -H \quad (19)$$

$$F = -H$$

n	Tensile demand of single propeller F _n [N]	Ceiling H _{max} [km]
1	56.64	3.25
2	45.59	8.22
3	41.48	9.65
4	39.15	10.40
5	37.81	10.82
6	36.78	11.13
7	36.05	11.35

Figure 16: Table 4 .Table 4 :

7 C) WINGTIP CONNECTION CAN INCREASE ENDURANCE TIME

5

n	Current [A]	Flight time [min]	Endurance improvement
1	29.93	256.6	0.00%
2	21.78	352.7	37.45%
3	18.97	404.8	57.76%
4	17.45	440.2	71.55%
5	16.59	463.0	80.44%
6	15.93	482.0	87.83%
7	15.48	496.2	93.37%

Figure 17: Table 5 :

163 .1 Acknowledgments

164 The authors are grateful for the financial support from the China Aviation Science Foundation Program
165 (201829U8007). They would also like to thank the Aeromodelling Team of RFUE for providing support.

166 .2 Data Availability

167 The aerodynamic parameters in this paper are calculated by xflr5 v6.48, and the file has been uploaded. The file
168 name is model.xfl.

169 .3 Conflicts of Interest

170 The authors declare that there is no conflict of interest regarding the publication of this paper.

171 [Köthe et al. ()] ‘Closedloop flight tests with an unmanned experimental multi-body aircraft’. A Köthe , A
172 Behrens , A Hamann . *17th International Forum on Aeroelasticity and Structural Dynamics*, (Como, Italy)
173 2017.

174 [Magill ()] *Compound aircraft transport study: wingtip-docking compared to formation flight*, S A Magill . 2002.
175 Blacksburg, Virginia, USA. Virginia Polytechnic Institute and State University

176 [Anderson ()] ‘Dangerous experiments: wingtip coupling at 15,000 feet’. C Anderson . *Flight Journal* 2000. 5 (6)
177 p. .

178 [Cooper and Rothhaar ()] ‘Dynamics and control of in-flight wing tip docking’. J R Cooper , P M Rothhaar .
179 *Journal of Guidance Control & Dynamics* 2018. 41 (11) p. .

180 [Wu et al. ()] ‘Effect of wingtip connection on the energy and flight endurance performance of solar aircraft’. M
181 Wu , Z Shi , T Xiao . *Aerospace Science and Technology* 2021. 108 p. 106404.

182 [Wlach et al. ()] ‘ELAHAElastic aircraft for high altitudes concept and current development state of an
183 unconventional stratospheric UAV’. S Wlach , G Balmer , M Hermann . *23rd ESA Symposium on European
184 Rocket and Balloon Programmes and Related Research*, (Visby, Sweden) 2017.

185 [Collin and Montalvo ()] ‘Experimental control of two connected fixed wing aircraft’. C Collin , C Montalvo .
186 *Aerospace* 2018. 113 (5) p. .

187 [Fang et al. ()] Z Fang , W Chen , S Zhang . *Flight dynamics of aircraft*, (Beijing) 2005. Beihang University
188 Press.

189 [Yang et al. ()] ‘Flexible modular swarming UAV: innovative, opportunities, and technical challenges’. Y Yang ,
190 Z Zhang , P Ying . *Flight Dynamics* 2021. 39 (2) p. .

191 [An et al. ()] ‘Flight mechanical analysis and test of unmanned multi-body aircraft’. C An , C Xie , Y Meng .
192 *International Forum on Aeroelasticity and Structural Dynamics*, (Savannah, Georgia, USA) 2019.

193 [Chen and Katz ()] ‘Induced drag of high-aspect ratio wings’. T Chen , J Katz . *42nd AIAA Aerospace Sciences
194 Meeting and Exhibit*, (Reno, Nevada, USA) 2004.

195 [Montalvo and Costello ()] ‘Meta aircraft connection dynamics’. C Montalvo , M Costello . *AIAA guidance,
196 navigation, and control conference*, (Minneapolis, Minnesota, USA) 2012.

197 [Montalvo and Costello ()] ‘Meta aircraft flight dynamics’. C Montalvo , M Costello . *Journal of Aircraft* 2015.
198 52 (1) p. .

199 [Montalvo ()] *Meta aircraft flight dynamics and controls*, C Montalvo . 2014. Atlanta, Georgia, US. Georgia
200 Institute of Technology

201 [Wang et al. ()] ‘Miniature fixed wing UAV swarms: review and outlook’. X Wang , Z Liu , Y Cong . *Acta
202 Aeronautica et Astronautica Sinica* 2020. 41 (4) p. .

203 [Zhou et al. ()] ‘Overview of UAV link wing system technology’. R Zhou , W Zhou , D Wang . *the 5th Joint
204 Conference of Aerospace Propulsion (JCAP) Technical Conference*, (Nanjing) 2020. p. .

205 [Zhou et al. ()] ‘Research progress of combined fixed-wing unmanned aerial vehicle based on wingtip chained’.
206 W Zhou , P Ma , Z Guo . *Acta Aeronautica et Astronautica Sinica* 2022.2022. 43 (9) p. .

207 [Cobar and Montalvo ()] ‘Takeoff and Landing of a Wing-Tip-Connected Meta Aircraft with Feedback Control’.
208 M Cobar , C Montalvo . *Journal of Aircraft* 2021. 58 (4) p. .