



GLOBAL JOURNAL OF RESEARCHES IN ENGINEERING: F
ELECTRICAL AND ELECTRONICS ENGINEERING
Volume 23 Issue 1 Version 1.0 Year 2023
Type: Double Blind Peer Reviewed International Research Journal
Publisher: Global Journals
Online ISSN: 2249-4596 & Print ISSN: 0975-5861

FPGA Physical layer Implementation of Fixed WIMAX for Data Transmission

By Vasanth Kumar TR & Dr. K V Prasad

Jain University

Abstract- The telecommunication area in last decade has witnessed the interest towards the providing the quality of service to the users but achieving this QoS with increasing users as the most significant issue. As a result, various technologies have come into existence. The broadband wireless access is one of the ways to reach the high business demand for increasing the internet connection. The wireless solution has been found to remove the limitations in capacity in comparison to wired technologies. The significant technique called OFDM (Orthogonal Frequency Division Multiplexing) provides the better QoS but leads to high Cyclic Prefix (CP). The implementation of WiMAX standards on FPGA is a big challenge as this wireless standard is a complicated standard. The hardware modeling made here to simulate the physical layer of WiMAX on FPGA evaluates the system performance. This paper introduces a design of WiMAX physical layer implemented over FPGA and analyzes the performance of the implemented system. The methodology here is first to design the hardware architecture of the system being implemented on the FPGA and then to transfer the design on the FPGA board. The system performance is evaluated by generating a random digital data and transferring the data from the transmitter on the implemented communication system. The received data is then compared with the transmitted data to evaluate the Bit Errorrate of the implemented system.

GJRE-F Classification: FOR Code: 090699



Strictly as per the compliance and regulations of:



© 2023. Vasanth Kumar TR & Dr. K V Prasad. This research/review article is distributed under the terms of the Attribution-NonCommercial-NoDerivatives 4.0 International (CC BYNCND 4.0). You must give appropriate credit to authors and reference this article if parts of the article are reproduced in any manner. Applicable licensing terms are at <https://creativecommons.org/licenses/by-nc-nd/4.0/>.

FPGA Physical layer Implementation of Fixed WiMAX for Data Transmission

Vasanth Kumar TR^α & Dr. K V Prasad^σ

Abstract- The telecommunication area in last decade has witnessed the interest towards the providing the quality of service to the users but achieving this QoS with increasing users as the most significant issue. As a result, various technologies have come into existence. The broadband wireless access is one of the ways to reach the high business demand for increasing the internet connection. The wireless solution has been found to remove the limitations in capacity in comparison to wired technologies. The significant technique called OFDM (Orthogonal Frequency Division Multiplexing) provides the better QoS but leads to high Cyclic Prefix (CP). The implementation of WiMAX standards on FPGA is a big challenge as this wireless standard is a complicated standard. The hardware modeling made here to simulate the physical layer of WiMAX on FPGA evaluates the system performance. This paper introduces a design of WiMAX physical layer implemented over FPGA and analyzes the performance of the implemented system. The methodology here is first to design the hardware architecture of the system being implemented on the FPGA and then to transfer the design on the FPGA board. The system performance is evaluated by generating a random digital data and transferring the data from the transmitter on the implemented communication system. The received data is then compared with the transmitted data to evaluate the Bit Errorrate of the implemented system.

I. INTRODUCTION

The popularity of Broadband Wireless Local Area Network (WLAN) over cable modems in past decade has encouraged the development of a wireless standard for Metropolitan Area network (MAN). In an account of this, a broadband wireless access standard named WiMAX (Worldwide Interoperability for Microwave Access) has come into existence [1]. This standard is recently gaining importance due to high demand for high-speed internet access. The WiMAX also termed as IEEE 802.16 standard can provide a data rate starting from 100Mbps and a maximum range of 50 km for line of sight connectivity and 25km for Non-line of sight connectivity [2].

WiMax operates in 2.5, 3.5 and 5.8 GHz bands of frequencies using Orthogonal Frequency Division Multiplexing (OFDM) technology in the physical layer. The OFDM signaling is implemented to achieve higher performance for multipath fading wireless channels. Apart from this physical layer may incorporate other

functions such as randomisation, forward error correction and sometimes coding for multiple antenna technologies.

The design of a WiMAX system is influenced by critical requirements such as higher speed, flexibility, time to market and importantly the hardware platform selection. For the high-speed system, the platform has to support significant processing capabilities that can perform computationally intensive tasks such as FFT/IFFT, FEC, etc. Flexibility is another requirement that a WiMAX design is to incorporate as the Standard is under continuous revision process. In such scenarios, the WiMAX system should be designed with hardware flexibility to achieve in-field reconfigure ability. Finally, the time to market is an important criterion for gaining success in market share. The Digital Baseband physical layer can be implemented using a general-purpose processor or a DSP processor which can run several algorithms mimicking the signal processing operations of the physical layer. The other methods of implementing the system are to develop a custom Application Specific Integrated Circuit (ASIC) or use an FPGA to configure the device as WiMAX physical layer system.

The use of DSP based algorithm to implement a system involves lot of computational complexity which may result in delays in generating the output signal. The ASIC implementation is a very time-consuming and expensive which affects the time to market of the implemented design. However, FPGA implementation does not suffer from the above two issue. Hence to design a WiMAX system with such criteria FPGA's provide an ideal implementation platform.[1]

This paper discusses about the implementation and performance analysis of WiMAX system. The transmitter and receiver sections are designed with a Channel and implemented on FPGA module. The channel module models the noise that mixes with the transmitted signal and passes the noise added signal to the receiver. The implementation of the system is verified by transmitting a binary sequence of data through the transmitter sections, allowing the transmitted signal to enter the receiver and extracting back the binary sequence of data. The WiMAX system implemented here makes use of an additive White Noise module that is implemented in hardware to act as a source of noise to the signal.

Author ^α: Research Scholar, Jain University Bangalore.
e-mail: vasanthkumar.tr@gmail.com

Author ^σ: Professor and Hod, Bangalore Institute of Technology, Bangalore.

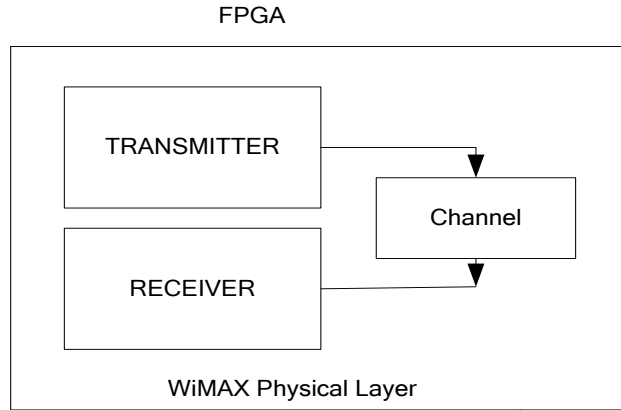

Figure 1: Wimax FPGA Implementation

a) Background

The WiMAX is a form of wireless transmission architecture which provides the speedy communication at low maintenance cost. This also gives the better use of bandwidth at higher frequency level. This part of the paper discusses the necessary concepts of the WiMAX system and its physical layer.

i. WiMAX system

The architecture of WiMAX system composed of various units in which base station (BS) and sink station (SS) are significant. Other components are CSN, MS, ASN, and CSN-GW, etc. The WiMAX Forum's Network Working Group (NWG) provides a network reference model according to the IEEE 802.16e-200. The reference model is logically divided into three units [5].

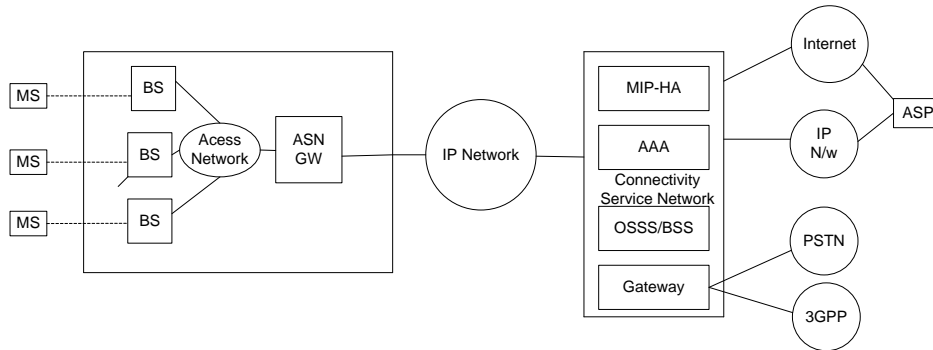

Figure 2: WiMAX Network architecture

Mobile Station (MS): This acts as end-user equipment for accessing the mobile network. It is portable and provides data and voice communication facilities to the users.

Access Service Network (ASN): This is a network that provides access services with efficient scalability and high mobility. Its ASN-GW controls the network and coordinates among data and networking elements.

Service Network (CSN): Provides IP-connectivity, address and policy management, managing location between ASN, ensuring Quality of Service, roaming facility, and security.

ii. WiMAX Physical layer

This layer is mainly responsible for setting the connection among the communicating devices and transmission of the data bits. The physical layer design defines modulation type and transmission power requirements. WiMAX physical layer has two types of transmission techniques Time Division Duplex and

Frequency Division Duplex with operating frequency band below 11 GHz. The physical layer of IEEE 802.16 standard is based on OFDM which is mainly required for multimedia communication and digital video services as it provides very fast data speed on non-line of sight channels and multipath environment. The role of the PHY layer is to encode the MAC frames into analog signals and receive these signals from a communication channel [7].

b) Research Problem

The implementation of the physical layer of WiMAX system poses big challenges as this is a complicated standard and high-speed processing requirement. There are very few works that focussed on implementing the WiMAX physical layer on FPGA system, but design constraints could not satisfy for the real-time hardware implementation of the system. Here an effort is made to realize a Physical layer of WiMAX on

FPGA system with an improved throughput and FPGA design parameters.

II. LITERATURE REVIEW

This unit gives the discussion of the various research works towards the design and implementation of WiMAX based OFDM transmission system. Moises Sera [5] presented OFDM transmitter design as a part of Hiperlan/2 based transmitters. The issues in the implementation of OFDM based WLAN standard was presented by Ma.Jose Canet [6]. His work focussed on providing solutions to Baseband and IF OFDM signal generation. The work also benchmarked Optimised area results against system Generator results. Chris Dick[7] emphasized on designing the Software Defined Radio system on FPGA rather than on ASIC as FPGA provides a one-day solution to the implementation. His work provided a high-level view of FPGA implementation of OFDM receiver consisting of synchronization, packet detection; preamble correlates channel estimation and equalization functions. The implementation of 802.11 wireless standards on FPGA as a validating and prototype for ASIC was presented by Ludovico de Souza[8].Joaquin Garcia ad Cumplido [9] investigated the suitability of FPGA to support IF processing for 802.11a standard. The work majorly focussed on resource area and timing requirements that suit the implementation of rapid prototyping and also providing reconfiguration capability to support the different wireless standard. Awad et al. [10] implemented the physical layer of IEEE 802.20 and investigated the efficiency of OFDM transceiver. Lin [11] demonstrated the OFDM concept and investigated its efficiency changes by change in different parameters. The OFDM system was demonstrated by implementing the design in Matlab. Mohamed [12] presented an approach to implementing the OFDM system on FPGA. Harikrishna [13] presented FFT algorithm implementation on FPGA for WiMAX application. The author presented a memory based recursive FFT design which takes fewer gates, lower power and operates at high speeds. Upadhyaya et al. [14] presented an efficient FPGA implementation of address generation circuit for WiMax deinter leaver. A QAM architecture for WiMAX application covering carrier synchronization and timing synchronization issues was presented by Sahoo et al. [15].

III. PROPOSED SYSTEM

The OFDM physical layer system described here is an extension of the system described in chapter in chaper3 with few modifications that are added to the design. The modification to the hardware architecture of chapter1 includes the addition of Forwarding error correction technique. A convolution encoder for correcting the random errors and an inter leaver for

overcoming the burst error effects are added at the transmitter section. The corresponding inverse function blocks such as a de-interleaved and a Viterbi decoder are added to the receiver section.

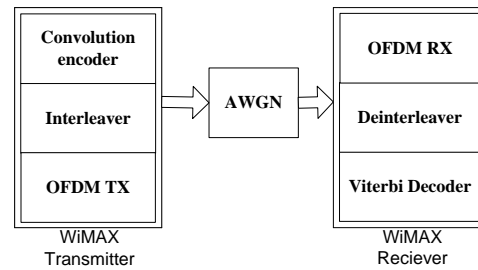

Figure 3: Design for Hardware implementation

a) Convolution Encoder

This module comprises four inputs and two outputs. The global clock (Clk), reset (rst) and enable input signal act as control signals to the encoder. The Din signal serves as a single bit data input to the encoder. The convolution encoder developed is an encoder with a code rate of 1/3; hence the encoder output is a 3-bit code word (Dout). The encoder is also designed to give another output En_out which is high for the proper and valid working of the encoder. The En_out is also required for proper synchronization of the output code word. The convolution encoder is implemented considering a state machine implementation which comprises memory element and a combinational circuit. The state machine for the convolution encoder consists of M single bit shift registers and n modulo-2 adders (Ex-or gates). The shift registers are connected to the adders based on a generator polynomial. The number of adders in the state machine gives the length of code words generated.

b) Interleaver

This block reorders the coded symbols to counter the effects of burst errors on the transmitted coded symbols. The reordering of the coded symbols spreads out the burst errors rather than localizing it.

c) OFDM TX

The interleaved coded bits are transferred into Tx block for generating the OFDM signal. The OFDM TX block includes the following hardware modules 16 QAM, Symbol generation, zero padding, IFFT and Cyclic prefix(CP). The interleaved coded sequence is converted to one of the 16-QAM modulation symbols by passing the sequence through a QAM modulator. The QAM symbols are then zero padded and passed to a 256 point IFFT block. The cyclic prefix appends a 48-bit cyclic prefix code to generate a complete OFDM symbol of 304 bits. The OFDM signal will then be transferred over the channel via a Parallel to serial converter.

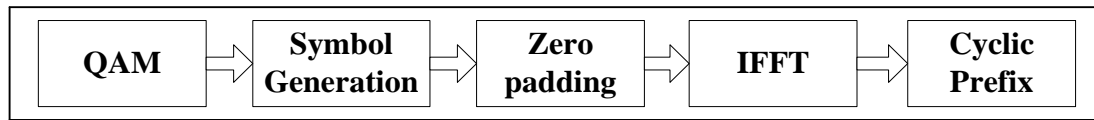

Figure 4: TX1 hardware blocks

i. *QAM*

The coded data to be sent on the subcarriers are converted to QAM symbols using a 16-QAM module. The input 4 bit data are mapped as one of the 16 QAM symbols. Each of the QAM symbols is represented as real and imaginary components after the mapping process. The input 4-bit data is transformed into 16 real parts and 16 imaginary parts.

ii. *Symbol generation*

This block constructs the OFDM symbol from the QAM symbols. In this block, the incoming QAM symbols are shifted four times to generate a single OFDM symbol. As the 16 bit Real and imaginary parts of each QAM symbol are shifted four times, the OFDM symbol constructed is of 64 bits. the incoming 16-bit QAM symbols are grouped in four to create an OFDM symbol of 64-bit.

iii. *Zero Padding*

The 64 bit OFDM sample is zero padded in this block. The real-part and imaginary-part of the symbols generated from the SG block will be input to the Zero padding block to pad zeros. The zeros are padded to increase the sampling rate of the symbol. The 64-bit symbol data will be padded with extra 64 zeros to construct a 128 bit real and imaginary symbol data.

iv. *IFFT*

The extended real and imaginary symbol data are passed through an IFFT block to generate the OFDM symbol. The IFFT module developed is a 256 point IFFT.

v. *Cyclic Prefix*

The Cyclic prefix module extends the OFDM generate from the IFFT block to mitigate the ISI effects. It extends the symbol by prefixing the OFDM symbol by repeating the tail part of the symbol generated from IFFT. The cyclic prefix developed here extracts the last 32 bits from the IFFT generated OFDM symbol and prefixed it to the start of the symbol. Thereby a total of 288 bit OFDM symbol is generated.

d) *AWGN Generator Module*

The AWGN generator module is used as AWGN Channel Noise module in Fixed-WIMAX system. The AWGN generator module generates the white Gaussian noise (WGN) of SND (standard normal Distribution). There are so many digital-synthesizing techniques are available to generate the random Gaussian variables depends on the transformation of UDR (Uniform distributed randomly) Variables. The hardware

architecture of AWGN generator module is designed by using different techniques [79] like Central limit theorem (CLT), Box-Muller (B-M) Method, Rejection-acceptance Methods, Wallace Method and ICDF (Inverse Cumulative Distribution Function). In our design, ICDF method is adopted.

e) *OFDM RX*

The OFDM signal received from the AWGN channel is passed through an RX block which consists of the following hardware modules; Inverse Cyclic Prefix, FFT, zero removal and QAM demodulator. The Inverse cyclic prefix removes the appended 48-bits of imaginary data and passes the 256 OFDM data to FFT block. The FFT block transforms the subcarriers to transform domain from which data is extracted by removing the zeros and demodulating. A 16-QAM demodulator maps the QAM symbols to code bits which will be forwarded to Inter leaver.

f) *Deinterleaver*

The deinterleaving operation is the reverse of interleaving. This operation is performed to rearrange the symbols that were interleaved in the transmitter section. The interleaving and deinterleaving operation are performed by reading and writing through memory buffers.

g) *Viterbi Decoder*

A Viterbi decoder is used at the receiver to decode the convolution codes. This decoder uses a Viterbi algorithm which uses trellis structure for decoding operation. The decoding of the convolution encoded sequence is performed by finding optimal path in the trellis structure for the received sequence. After obtaining the optimal path, a distance measure is used to received and coded sequence to perform decision decoding.

IV. RESULTS ANALYSIS

This section the performance of the model designed is evaluated under two conditions of the channel 1) with fading and 2) without fading.

a) *Simulation Outcomes*

The BER performance of the WIMAX system for these two systems is analyzed for the above mentioned two conditions and compared with the theoretically generated BER values for the designed system. The theoretical values are obtained using BER calculation module present in MATLAB software.

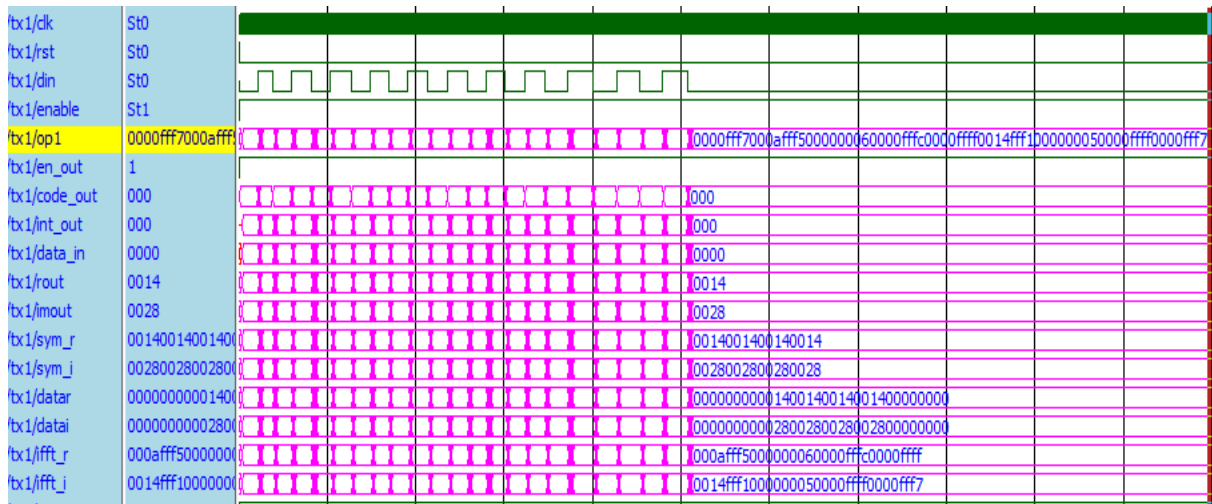

Figure 5: OFDM_FEC Transmitter Simulation waveform

The AWGN Generator simulation results are shown in the figure 5.44. When clock is activated, initial reset has high, then low. The enable sign is set high.

Based on the design modules like T-URNG and I-CDF module designs. The random 16-bit is generated.

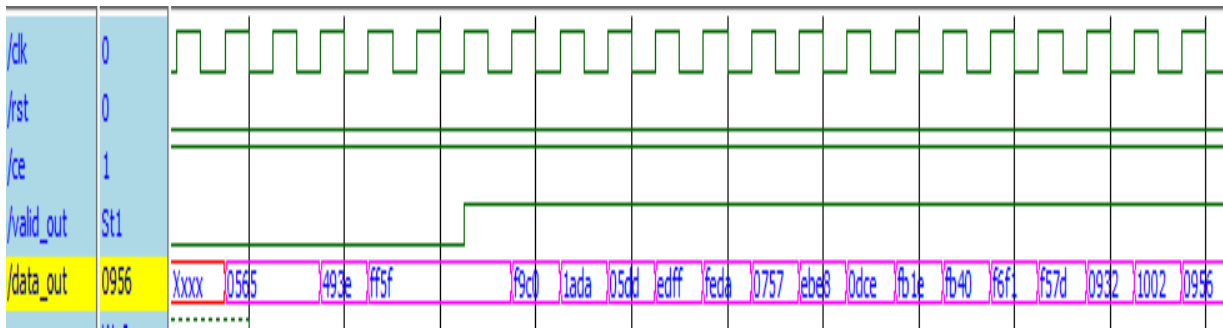

Figure 6: AWGN Generator simulation Results

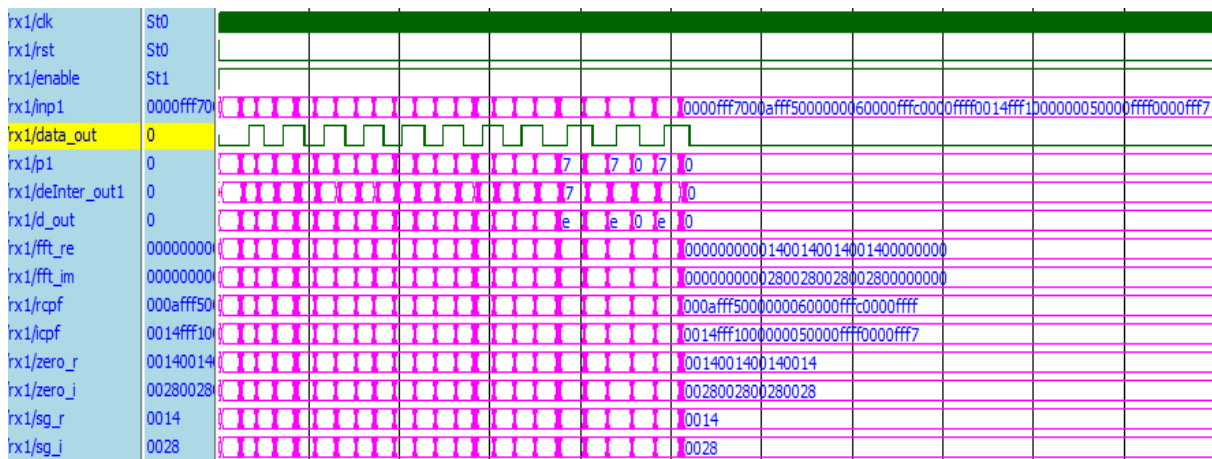

Figure 7: OFDM_FEC Receiver Simulation Results

b) Performance Analysis

i. WiMAX System

The total number of clock cycles to process each input bits information, the proposed design takes 2485 clock cycles it can also call it as Latency. The FPGA Operating frequency is set to 100MHZ and clock

period is set to 10ns. To process the 1024 bit data, the throughput or bit rate is calculated as follows.

$$\text{Throughput} = [1/ (2485 * 10 \text{ ns})] * 1024 \text{ bits} = 41.20 \text{ Mbps.}$$

Table 1: WiMAX Design comparison with work [16]

Optimization Parameter	Device: Kintex-7 FPGA		
	work[16]	proposed	Improvements
Latency (clock cycles)	3607	2485	31.06%
Throughput (Mbps)	28.3	41.2	31.31%

The latency and throughput are improved both around 32 % concerning previous WiMAX architecture [16]. The Bitrate complexity is reduced.

Similarly, the WiMAX system is area overhead, and hardware complexity is important in real-time implementations. So the proposed design is compared with work [17] for area constraints.

Table 2: Area used in WiMAX Systems comparison

Area used in WiMAX Systems	Virtex-6	Work [17]		Proposed		Area Improved
		Used	Utilization	Used	Utilization	
Logic Utilization	Available					
Number of Slice Registers	301,440	165,792	55%	8422	2%	94.92%
Number of Slice LUTs	150,720	102,490	68%	17516	11%	82.90%

In work [17], the design is used system generator to generate the VHDL Code; It consumes more area because the code is auto-generated by system. The proposed design is written in Verilog HDL, and both the designs are synthesized in Virtex-6 X240T-2FF784 FPGA for comparison purpose. The proposed design gives around 80-90 % improvement in area overhead concerning work [17] as shown in the table-5.2.

ii. WiMAX Receiver

The main part of the receiver is Viterbi decoder to decode the convolution encoded bits. The timing analysis of modified Viterbi decoder for WiMAX system related to work [18] on Vertex-6. The proposed design achieves the maximum operating frequency with 35 % improvement as shown in the table-5.3. So it will improve the overall bit rate.

Table 3: Viterbi Decoder Timing Comparison with Work [18]

Viterbi Decoder Timing Comparison		
Timing Analysis	Device -Virtex -6 FPGA	
	Work[18]	Proposed
Minimum period(ns)	15.5	10.083
Maximum Frequency(MHz)	64.516	99.179
Setup Time(ns)	20.8	1.537
Hold Time(ns)	5.8	0.659

The proposed modified Viterbi Decoder is compared with work [19] [20] for area for power consumption comparison as shown in the table-4.

Table 4: Viterbi Decoder Area and power Comparison with Work [19][20]

Viterbi Decoder Area and Power Comparison			
Parameters	Virtex2 -2000	Zynq-7000	Zynq-7000
	Work[19]	Work[20]	Proposed
Total Power (mW)	NA	106	100
Slices	3444	NA	1918
LUT's	6303	5614	3201

The proposed modified Viterbi Decoder improved the area with respect to work [19] with 44.33% slices and 49.21 % LUT's improvements. Similarly, with

work [20], 42.98% LUT's improved and 6% improved in total power reduction in proposed modified Viterbi Decoder.

The Proposed WiMAX system checks the BER Rate, The number of bits transferred 100 and the number of errors occurred during the processed time interval is 14. So the BER rate is 0.14. Intermis of percentage is 14%.The original number of bits recovered is 86%.

V. CONCLUSION

WiMAX is a wireless Broadband access technology that implements the Wireless MAN (IEEE 802.16) standard. A WiMax physical layer was designed such that it can be efficiently implemented on FPGA system with improved throughput and reduced design parameters such as area and power. The system was designed with Forwarding error correction capability and also the design incorporated a channel model that generated AWGN signal. The performance of the system was analyzed by comparing it with other designs. The design presented in this paper proved to provide a better throughput than other designs. The BER rate is performed better out of 100 bits, errored bits are 14, and the Original bits recovered is 86%. The BER Rate is 0.14.

REFERENCES RÉFÉRENCES REFERENCIAS

1. "Accelerating WiMAX System Design with FPGAs" Copyright © 2004 Altera Corporation.
2. Kareem, Mr. Qasim H., and Mahmood AK Abdulsattar. "FPGA-Based Implementation of IEEE 802.16 d WiMAX Baseband system." *International Journal of Application or Innovation in Engineering & Management* 3 (2014).
3. Kaiser.S "Spatial transmitter diversity techniques for broadband OFDM systems", IEEE Conference on Global Communications, Vol. 3, Nov-2000, P.P.1824-1828.
4. Dharavathu, Krishna, M. Satya Anu Radha, and M. Siva Sankar Nayak. "Image Transmission and Hiding Through OFDM System With Different Encrypted Schemes." *International Journal on Future Revolution in Computer Science & Communication Engineering*, Volume: 3, 2017.
5. M. Serra, J. Ordiex, P. Marti and J. Carrabina, "OFDM Demonstrator: Transmitter" in Proc 7th International OFDM Workshop 2002, Sep 2002.
6. Ma. J. Canet, F. Vicedo, J. Valls and V. Almenar, "Design of a Digital Front-End Transmitter For OFDM-WLAN Systems Using FPGA", *Control, Communications and Signal Processing* 2004, First International Symposium on, pp: 503-506, 2004.
7. C. Dick and F. Harris, "FPGA Implementation of an OFDM PHY" *Signals, Systems and Computers*, 2003. Conference Record of the Thirty-Seventh Asilomar Conference, Vol.1, pp: 905-909, Nov. 2003.
8. L. de Souza, P. Ryan, J. Crawford, K. Wong, G. Zyner and T. McDermott, "Rapid Prototyping of 802.11 wireless modems", *Solid-State Circuits Conference*, 2001. Digest of Technical Papers. ISSCC 2001 IEEE International, pp: 339-495, Feb.2001.
9. Y. Kim, H. Jung, H. Ho Lee and K. Rok Cho and F. Harris, "MAC Implementation for IEEE 802.11 Wireless LAN", *ATM (ICATM 2001) and High-Speed Intelligent Internet Symposium*, 2001. Joint 4th IEEE International Conference on, pp. 192-195, Apr. 2001.
10. Y. Awad, L. H. Crockett and R. W. Stewart, "OFDM TRANSCEIVER FOR IEEE 802.20 STANDARDS".
11. P. G. Lin, "OFDM simulation in MATLAB", a senior project, faculty of California Polytechnic State University, San Luis Obispo, June 2010.
12. M. A. Mohamed, "FPGA-BASED DESIGN OF OFDM SYSTEM", *the Mediterranean Journal of Computers and Networks*, Vol. 7, No. 1, pp: 163-170, 2011.
13. Harikrishna, K., and T. Rama Rao. "FPGA based FFT algorithm implementation in WiMAX communications system." *Wireless Communication, Vehicular Technology, Information Theory and Aerospace & Electronic Systems Technology (Wireless VITAE)*, 2011 2nd International Conference on. IEEE, 2011.
14. Upadhyaya, Bijoy Kumar, and Salil Kumar Sanyal. "Efficient FPGA implementation of address generator for WIMAX deinterleaver." *IEEE Transactions on Circuits and Systems II: Express Briefs* 60.8 (2013): 492-496.
15. Sahoo, Subrat Kumar, Maasima begum, and G. Kalyan. "Design and Implementation of QAM Architecture on FPGA for WiMAX Applications."
16. Hadiyoso, Sugondo, Rina P. Astuti, and Iswahyudi Hidayat. "Design of an FPGA-based OFDM-STBC transceiver for WiMAX 802.16 e standard." *Information and Communication Technology (ICICT)*, 2014 2nd International Conference on. IEEE, 2014.
17. Salah, Mohamed, Abdel-Halim Zekry, and Mohammed Kamel. "An efficient FPGA implementation of OFDM physical layer for SDR-based applications." *Computer Engineering Conference (ICENCO)*, 2014 10th International. IEEE, 2014.
18. Chakraborty et al. "Speed optimization of an FPGA based modified Viterbi decoder." *Computer Communication and Informatics (ICCCI)*, 2013 International Conference on. IEEE, 2013.
19. Zhou, Li, et al. "A flexible Viterbi decoder for software defined radio." *Journal of Theoretical and Applied Information Technology* 47.2 (2013): 702-706.
20. Mostafa, Khlood, et al. "High performance reconfigurable Viterbi Decoder design for multi-standard receiver." *Radio Science Conference (NRSC)*, 2016 33rd National. IEEE, 2016.