



GLOBAL JOURNAL OF RESEARCHES IN ENGINEERING: F
ELECTRICAL AND ELECTRONICS ENGINEERING
Volume 22 Issue 2 Version 1.0 Year 2022
Type: Double Blind Peer Reviewed International Research Journal
Publisher: Global Journals
Online ISSN: 2249-4596 & Print ISSN: 0975-5861

A Review on Smart Car Parking System

By Rani Astya, Soni Jain, Sukriti Sachan & Aish Aggarwal

Sharda University

Abstract- Nowadays vehicle parking has become an important issue and the need is increasing day by day. Growing population in metro cities is leading to huge vehicle density, the problems for car parking has become an unending question. In India we are still using a manual vehicle parking system and that is why we are struggling with the waste of time and fuel problem. When we need to park our car, we need to park our car. The conventional parking systems do not have any intelligent monitoring arrangement; causing wastage of time to find the slot and traffic on the way to park. Conditions are worse when there are multiple lanes and multiple parking slots. In this paper, we present an incisive overview of different methods and tools used in implementation of smart parking systems.

Keywords: *vehicle detection, tracking, parking, sensors, cars.*

GJRE-F Classification: *DDC Code: 725.38 LCC Code: TL175*



Strictly as per the compliance and regulations of:



© 2022. Rani Astya, Soni Jain, Sukriti Sachan & Aish Aggarwal. This research/review article is distributed under the terms of the Attribution-NonCommercial-NoDerivatives 4.0 International (CC BYNCND 4.0). You must give appropriate credit to authors and reference this article if parts of the article are reproduced in any manner. Applicable licensing terms are at <https://creativecommons.org/licenses/by-nc-nd/4.0/>.

A Review on Smart Car Parking System

Rani Astya ^α, Soni Jain ^σ, Sukriti Sachan ^ρ & Aish Aggarwal ^Ω

Abstract- Nowadays vehicle parking has become an important issue and the need is increasing day by day. Growing population in metro cities is leading to huge vehicle density, the problems for car parking has become an unending question. In India we are still using a manual vehicle parking system and that is why we are struggling with the waste of time and fuel problem. When we need to park our car, we need to park our car. The conventional parking systems do not have any intelligent monitoring arrangement; causing wastage of time to find the slot and traffic on the way to park. Conditions are worse when there are multiple lanes and multiple parking slots. In this paper, we present an incisive overview of different methods and tools used in implementation of smart parking systems. There are different approaches being researched upon by people including using IOT, different sensors, cloud or deep learning as well and all the different approaches being used by people have been mentioned in this paper. The paper presents a comparison of all the pros and cons for the approaches being presented by authors in different research papers.

Keywords: vehicle detection, tracking, parking, sensors, cars.

I. INTRODUCTION

In recent years, the world's population has increased, and hence the complexity of transportation has increased dramatically. With the increase in use of vehicles in cities, the problem of car parking has been raised. Smart parking is a parking strategy that combines technology and human innovation, aiming to use as few resources as possible, such as fuel, time and space, to park vehicles faster, easier and more densely during most of the time they are idle. The general approach to finding a parking spot is to aimlessly go around and drive until a free spot is found. This system would reduce empty parking space searching time. The user will automatically find the parking space by identifying entry and exit of the cars using the camera. It reduces the time wastage in finding the vacant parking lot for vehicles and also reduces the wastage of fuel Consumed while driving the cars or vehicles in the parking lot for finding the empty space to park vehicles. Time and fuel are wasted unnecessarily because the destination is unknown. A smart car parking system gives a visual result that reflects available parking space, rather than aimless driving. The smart car

Author α: Guide, Department of Computer Science and Engineering, School of Engineering and Technology, Sharda University, Greater Noida, Uttar Pradesh. e-mail: astyarani@gmail.com

Author σ ρ Ω: Student, Department of Computer Science and Engineering, School of Engineering and Technology, Sharda University, Greater Noida, Uttar Pradesh.

parking systems being introduced till now have presented multiple approaches and are focused on solving the problems being faced by people in their daily lives. The focal point of all the authors has always been to present the best they can. The different approaches introduced by them have been presented in this paper.

II. INTERNET OF THINGS BASED APPROACH

The approach proposed by Prof. Denis along with Akshat and Vipul Jigree in [1] has basically focused on the multi-storied parking areas along with the concept of Energy Conservation and Management. As per the approach, the vacant spaces will be depicted through lamps and the occupied ones will be virtually stored on the cloud which can further be accessed by the central system. The system consists of various components. It consists of a parking sensor working on Passive Infrared and Ultrasonic technology thereby detecting any human or vehicle presence. In order to update the vacancy status of the area, the data will be given via RJ25 interface, the moment the car will occupy the space it's status will be updated as 'Occupied' in the system's GUI. Following the Energy Conservation, after a while of the car being parked the lights will be dimmed, which will get illuminated when the owner returns to the vehicle. The system will have data depicted for different floors for multi-storied systems. An external source of Zigbee has been used in order to get the vehicle as well as owner's data being stored.

The architecture presented in this paper has been divided into three major constituents, the device which can be considered as any device assembling the data as per the segregation; edge server is the one being deployed in a LAN network connecting with the communication channels and the cloud server connecting the controller in order to manage the energy, also it provides the requirements needed for computation. Also, the software model is being segregated into several different layers starting from related to sensing generating the information and maintaining the connection, followed by the networking related to the transfer of data among the devices as well as server. The layers also include the awareness regarding the environment including the processing, configuration and the optimization as well. The last layer includes the features related to the management and the network. The proposed system focuses on saving time and power. Also the proposed system provides an enough spacing facility in order to avoid the unstructured layout and to manage a maintained approach as well.

a) *RFID & LCD based*

The approach proposed in [2], focused on providing a user friendly and reliable parking system. According to the approach the vehicle that needs to be parked will be provided with a unique id. In this system, as soon as the vehicle enters, the driver needs to deboard and look for the parking availability. Then the user will need to select any one slot of his choice from the available ones so that with the help of mechanical structure the car can be parked at that slot. The vehicle will trace the path to the slot as well. The time when the vehicle will be parked it's details will be sent to the Car Control Unit and further the status will be updated on the LCD as well.

The system follows some major steps and uses some components in order to follow the algorithm of the approach. The user's details will be checked and verified at the Verification Unit and thereby will be provided with a smart card. Also for security, a password will be given as well. There will be a floor indicator depicting the status if a slot is available or not. The LCD will show the details of the occupied and left spaces as well. The system will consist of some hardware and software components. LCD, DC Motor, RFID tag will be used for the hardware.

Also microcontrollers will be used so that the program memory can be re-programmed in the system. Also the RFID will be used as the user will receive a distinct ID, by which movement can be identified. In order to support different designs of microcontroller, Proteus 8 will be used.

The paper[15] presented the concept of having multiple sensors detecting vehicles and further sending the data to the server. The system involves steps like checking for the free slots, getting the fastest route as well. Further the user will be getting a different QR Code while parking at the slot. The user will receive the details regarding the booking and parking on the registered phone numbers and further they'll be getting the access via RFID Card and Token. The system involves multiple modules, QR Code Module, RFID Module, GSM Module, server, power, motor etc connected via the Arduino Mega. The requirements for the system are Arduino mega, IR Sensors, Servo Motor, RFID, GSM and QR Code Module's. The system starts with logging in to the application, followed by the process of accessing via RFID or Token thereby receiving the QR Code and so users can further book the slots and work towards the navigation process as well.

b) *NB-IOT based*

Praveen & Harini in [5] has discussed the NB-IOT technology for the approach. The NB-IOT Technology provides various benefits and provides efficient solutions among the communication devices. The technology ensures a greater coverage of the network and requires enough signal penetration and is

slightly variant as compared to rest of the technologies in use whether the radio frequency one or any third party technology. The Narrowband technology facilitates enough maintenance and a great reliability with better quality. Also, it provides a better data generation.

The approach is to provide a mobile application working with the help of NB-IoT technology. The user will be needed to get registered on the application with all the details, after logging in one can check the availability of the slot, and the user can book the slot. The available and unavailable slots will be displayed with different colors to the user and the timer will be started on parking, if the timer exceeds a notification will be sent to the user. The system consists of various hardware equipment like sensors, which allows it to detect the presence of vehicles. The status will be transferred to the central server which then processes the payment transaction as well. Parking meter will specifically for the payment procedure as per the time for which the vehicle is parked. Further, the central server will be used for communication with all the peripherals being used in the system. Also, the system consists of a Buzzer, which will be having a number of sensors connected to the server sending a warning in the form of continuous beep sound.

c) *GSM based*

The approach presented in [3] presents a concept of transfer of data through a network without human interactions with the help of IoT. IoT provides wireless technologies at an affordable price along with transferring data to the cloud. The approach is focused on using sensors thereby analysing and processing the data, further the data will be transmitted to the transmitters in the form of output. The useful data then be extracted and will be further given to Arduino. The system also consists of a servo motor and a GSM module, which will then be instructed with Arduino. The RFID card is provided to the user on entrance which then can be scanned by user module keeping the privacy and security constraints. Also RFID enables the user to detect the availability of the spaces and give the notification to the registered number as well.

The system is basically segregated into three modules, first one working upon the parking area with the help of Arduino and Infrared Sensors. The second one will be working with the cloud web series that will be acting as a mediator between the area and the user. As soon as the changes happen in the area, the cloud will also get updated for the same. Then the last section is basically the one presented to the user. Users will be receiving the notification regarding free slots via SMS. The user can interact with the cloud as well as the parking area. The user will be notified for all occupied as well as the free spaces. The user will be given an RFID card, which will be required every time while an entry having details of the user will be scanned and thereby

details being transferred. Then as per the approach the sensors will check for the available spaces and the user will be notified for the same. The activity of the user then will be stored in the cloud.

The idea of a miniature model of an automated car parking system proposed in [6] by Bonde. D.J Shende, Kedari, Gaikwad, K.S & Bhokre focused on developing a system providing an automated parking system. The system proposed a LCD for displaying the number of cars parked and the free slots for more cars to be parked. As the user enters the parking area, he/she would deboard the vehicle and with the help of application the command of car to be parked will be given, the car would be following the path towards the parking space further following the path towards the free slot. The data for the same will be updated on the LCD automatically. The proposed model will be working on four major modules, the first one will be the LCD interfaced with microcontroller, GSM interfacing the microcontroller, followed by the interfacing of microcontroller with RF module and Android application. The whole methodology has been divided into two, an architecture for cars and another for the parking area. The android application will be helping in order to command the parking system, and the system installed in the car will further look for the movement of the car following the commands. The android application will be connected with the GSM module, further working with microcontrollers. The microcontroller will update the details on the LCD as well as connect with the RF module of the parking system which will be further connected with the RF module of the car. The RF module in turn will be connected to the sensors via the microcontroller and hence working with the engine. The data received from the application or the microcontroller will be stored in the buffer of GSM. Also the Rf module has been used in order to maintain an inter microcontroller communication. The mathematical model used in the system will be expressed in two functions, one for searching the free space and other to retrieve the car from the system.

$C:P \setminus ES$[6]{equation 1, where C is the "Park My Car" function, implementing sequential search, I denoting the set of slots, ES giving the empty slots and P will be depicting the set of parking space}

$GS \setminus T$[6]{equation 2, where G will be denoting the "Get My Car" function, S and T be denoting the strip numbers in the parking area and the direction whether left or right respectively}

III. CLOUD-OF-THINGS BASED APPROACH

The approach proposed by [4] has been focusing on locating a free parking slot in order to reduce the time of the user. The system proposes, collects and filters out the raw data further extracting

features by applying filtering and fusion techniques in order to prevent the transmission of extra data over the network. The transformed data will further be sent on cloud in order to process and evaluate using the ML algorithms.

The proposed system consists of sensor nodes, the indoor system is in the basement area and that of outdoor one is outside, other than that there are microcontroller devices. Cloud will act as an intermediary factor amongst the car parking and the application. The major objective of this system is to collect the sensor's data in order to detect the presence of vehicles in parking slots with the help of WSN. In order to handle the sensor generated information, a middleware architecture will be needed. The sensors will be assigned to the parking system of indoor as well as outdoor for gathering information which will further be evaluated and processed using the IoT devices. The processed information will further be processed by the ML algorithms. Android application will help in order to locate the closest car parking slots further users can avail the nearest vacant slot. Bluetooth will be further used in order to achieve communication amongst the sensors and microcontrollers. The HTTP protocol fulfills the purpose of establishing communication between users and the cloud.

The automated parking system proposed in [7] has used the RFID card for storing information of every vehicle entering in the parking space. The system has been designed as such to calculate the time from entry to exit, and consists of software as well as the hardware equipment. Also, the system will have LED displaying the available slots and the parked ones as well. The RFID will be used in order to identify and track tags attached to the objects, which will further be stored in the database. The system has been deployed in a local server as well as in Microsoft Azure Cloud. Further the system will be having two types of users, VIP and the regular one.

The system has been designed by segregating the users into two, regular ones for whom the slots would not be reserved and they have to park only on the available ones whereas the VIP ones can have their slots reserved, also they would be having their own RFID tag whereas the others have to take it while entering in the area itself. The system is further being segregated into two, the entry system and the other is the exit system. The entry system would store the data of the users with the scan of the RFID tags (for the regular ones) or the scanned VIP's cards. While exiting, as per the delayed time from the allotted one the payment of the user would be calculated which can be paid in postpaid and prepaid manner as well. The system also provides the space of two admins as super admin and admin as well and further the access will differ as per the designation as well.



There are multiple hardware's being used in the system, the RFID booth while entrance will be using ATmega328P along with the 32k ROM AND 2k RAM as the microcontroller, the card being scanned would be storing the card number along with the vehicle details. The camera would be capturing the images of the vehicle maintaining the security as well. Also the web

server and DB server would be used. The User Interface of the system will be designed with the help of Java and JDBC working for the database with the help of MYSQL. The components required for the approach are readily available and one can use a cloud server in order to have remote access for the system, but the use of a cloud server may affect the efficiency of the system.

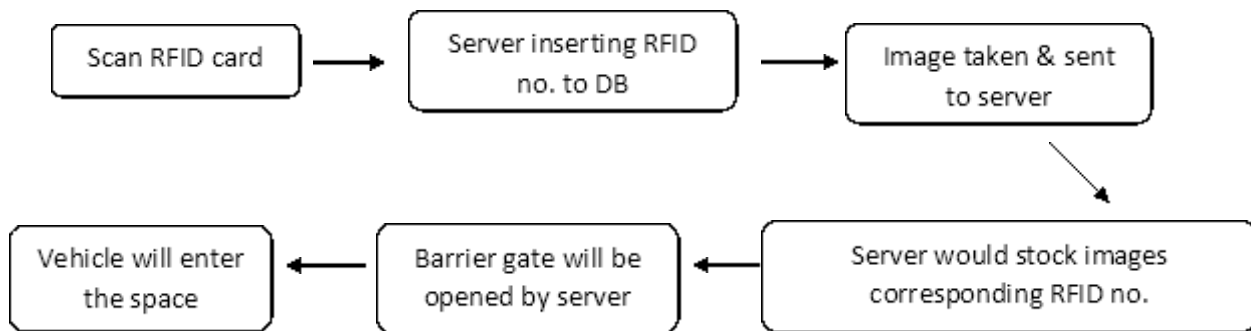

Fig. 1: Workflow diagram for the proposed approach

The system presented in [12] is focused on the idea of Internet of Things with the help of mobile applications connecting with the cloud. The system has aimed towards using cloud computing along with the IoT providing a good and low cost storage capacity and the data stored there can be retrieved with the help of IoT providing the real time processing along with providing communication resources. The proposed system focused upon the integration of Internet of Things with that of Cloud computing in order to get an improved functionality providing a better storage capacity for any kind of data and also it provides the computation needs required by the internet of things. Also this integration focuses on providing a cheaper and effective communication facility along with a better scalability approach.

The architecture of the proposed system has been segregated into several actors as per their uses, the parking sensors like Infrared, Passive in order to identify the vacant parking spaces followed by the processing unit consisting of Raspberry pi working as an intermediate between the cloud and the sensors. The TCP/IP protocol will develop the connections among the remote locations. The mobile applications will act as an interface for the user consisting of the system being designed via different languages and servers along with the data transfer as well. The IBM MQTT server will be hosted on cloud, keeping the track and records of the vehicles being parked and the spaces being vacant stored in the database. All the transmission of data would be handled via the JSON format between the server and the application. The database will track the payment, time duration permitting the system to add any number of users in the database due to its flexibility. With the help of mobile applications and following several steps users can easily get their cars being parked.

IV. IMAGE PROCESSING & ARTIFICIAL INTELLIGENCE BASED APPROACH

The proposed system in [9] is highly focused in order to replace the existing systems and has aimed not to use sensors and so is using image processing algorithms in order to automate the parking with the image from security cameras in the parking spaces. The algorithm would try to detect empty parking spaces and communicate information to drivers entering the parking space. The system has been implemented in MATLAB, by following some of the steps like that of image identification, acquisition, conversion thereby followed by enhancement and detection.

The architecture of the system has been segregated into several parts, the first step is of the image identification that is the coloured image would be converted into the HSV image describing the saturation variations of the image. This step would help the user to differ the green circle as per the input RGB value. Further the image might be converted to binary image with a specific threshold, less than which the image might come out as total black or white. The acquisition part will help in order to detect the vacant parking spaces with the help of the cameras. After having the view of the vacant spaces, the image would be converted in order to identify the objects. The architecture would be followed by the enhancement part, that would be done with the help of dilation as well as erosion. Dilation and erosion are a kind of opposites of each other, dilation increasing the boundaries in order to fill up the spaces in the objects followed by the erosion thereby decreasing the boundaries differing the objects and this process would help in distinguishing in a better way, also helping in identifying the vacant spaces. The last step for the algorithm is the detection

that would be done with the help of Circle Hough Transform that would be helping extracting the circles. As soon as the circles would be detected the diameter of each circle would be identified. The number of circles will be depicting the number of vacant spots.

The system given by [11] is focused towards image processing and artificial intelligence, consisting of various parts of the detection stage of license plate, information processing control system, network and application. The system uses Open ALPR and Node-RED along with some hypotheses as well, in order to implement the proposed objective. The camera's will be capturing the images of the license plates, thereby identifying if the car is parked or not. The ultrasonic waves will be used in order to identify and confirm the parking scenarios. The image processing step will be implemented in order to complete the first step of detection of the plate numbers with the help of Node-RED for the implementation part and which in turn will be using the tool Open ALPR.

The image processing will be conducted by segregating into several parts starting from the conversion from the coloured images to grayscale in order to identify the objects more clearly to the image acquisition which will be performed with the help of ultrasonic waves thereby confirming if the car has been parked or not, followed by the Node-RED and Open ALPR to be used in order to identify the results. The mobile application will also be segregated into different parts beginning with the time and the fee for the parking to the place for parking manager as well followed by the warnings for the ones not following the rules as well. The system requires quite a number of hardware as well for the implementation like, the communication hub acting as an interface in order to deploy the system and that interface will be Raspberry PI 3 board offering the peripherals with interface. This module will also communicate with that of cloud over the network along with the module of USB adapter to be used in order to transform the Raspberry Pi into a Wi-Fi router as well.

The system discussed in [14] presents a proposal for an identification and recognition system which provides a highly efficient system and can be used with respect to electronic toll collection as well as the check points. In order to maintain a uniqueness, the registration plates will be scanned via different recognition techniques. The presented system starts with capturing the image, followed by detection of the plates thereby segmenting and changing the files from the above step. The third step comes up with the idea of normalization and conversion of images into a binary one in order to create a background separation. Further the next step comes up with the use of OCR recognizing the characters of the plate. And at last the license plate will be detected.

The license plate detection will further be divided into several sub steps beginning with first

acquisition of the image along with segmentation the number plate converting into a variety of useful formats segmenting and labelling characters followed by character recognition providing the output file at the last.

a) *Miscellaneous Approaches*

The approach discussed in [8] focuses on working on lot and wi-fi technology providing a real time system. This parking system aims to ensure the user a real time reservation before the time of arrival. The proposed system has been worked out using a mobile application connected to Wi-Fi. The system will be using infrared sensors in order to monitor the free parking spaces. The user would need to check for the available spaces with the help of mobile application and further he/she can book the slot that they want to and the information would be shared with the users via notification. The details would be updated in the system as well. The architecture of the proposed system will consist of various elements like infrared sensors, LED lights, microcontrollers etc. The user would be needed to install the application for reserving their slots as per the available spaces. The user can decide the slot and park the car with the help of wi-fi connections via which the links would be created, either by using the IP address. The infra-red sensors would help in detecting objects or any obstacles, when the vehicle comes into space the sensor will transmit the modulated IR light, detecting the vehicle. Further the LEDs would simply be used in order to depict the empty and busy slots. The personal system will be keeping all the records of the whole system. It would be monitoring the count of vehicles being parked or left along with the payment procedures.

The system proposed by Bibi N. in [13] presented a vision based smart parking framework having the method of calibration in order to get the parking area to be segmented into blocks. The system will be dividing the process in different steps, starting with a web camera taking images and further performing image processing in order to represent car presence, counting them and even locating parking slots and further updating the status on the entrance. The video taken via camera would be segmented into frames, further the key frames will be extracted from different angles and the motion of the car will be detected by the key frame subtraction. The steps for thresholding, filtering and further creating frames round the slots would be created. The implementation of the proposed system will be performed via MATLAB and further the efficiency will be calculated as per the slots, number of cars and further taking the predicted numbers of the car. The idea of smart car parking proposed in [10] aims for the single or multi floor parking spaces with the help of a partial automated system. The system also focuses to let the user reach the nearest parking slot via less traffic route. The system works with the help of several

different equipment like during the entrance of the car. The IR sensors will be identifying its presence thereby opening the gates only if some vacant spaces are present. Several IR sensors would be installed near the slots updating information to the microcontroller whether there is available space or not. Further the slot would be selected by prioritising the path, slot, as well as the traffic congestion while reaching there. LED would help in detecting the suitable path indicating the user to use that route.

The IR sensors will help in detecting the available spaces, and the LED's will be indicating the path for the specified paths. The system will be working on the objective of combinations, the several combinations of LED paths will be stored in the microcontroller as per the priority of distance and the turns as well. The system will be using a PIC microcontroller providing a platform for all the operations, it acts as the main component controlling the working of all the other components. Apart from LED's and the controller, the DC motor will be used for the gates during the entry or exit. The actions will be converted to the commands with the help of electromagnetic Relays with a good supply.

V. CONCLUSION & COMPARATIVE STUDY

This paper presents an overview of the different techniques being researched upon by different people in order to develop an efficient algorithm for a smart car parking system. The approaches involved technologies like that of IOT, deep learning, AI etc. The most used approach is IOT and use of RFID tags and sensors. The approaches mentioned above do present efficient ways for the implementation of the algorithm but there are some disadvantages as well. Some of the approaches including sensors or RFID's turns out to be very expensive and are quite problematic to implement as well. There are systems being implemented by IOT having lots of hardware requirements and costing a great expense as well while on the other side there are systems trying to solve the disadvantages of the previous ones.

Ref. no.	Method Used	Advantages	Disadvantages
Denis Ashok et. al[1]	IOT	<ol style="list-style-type: none"> 1) Saves the customer time. 2) Provides a better safety constraint. 3) Provides Real Estate Optimization along with planning. 	<ol style="list-style-type: none"> 1) Requires a scope of improvement. 2) Low transmission. 3) Can't be used in an outdoor wi-fi system, due to the limited coverage system. 4) The privacy leakage
Jahnvi Nimble et. al[2]	IOT (LED/RFID)	<ol style="list-style-type: none"> 1) Efficient as due to its automation technique the parking system works quickly and efficiently. 2) Requires low maintenance. 3) The highly sensitive sensors will make the work easier and are easy to handle. 	<ol style="list-style-type: none"> 1) High cost when needed to be designed for a larger area. 2) Due to the use of several hardware components it will somehow affect the expenditure of the system.
ElakyaR et. al[3]	IOT (GSM)	<ol style="list-style-type: none"> 1) Users don't really need to wait as they will be notified for occupied as well as vacant spaces. 2) Saves time. 3) Users having access to the parking area. 	<ol style="list-style-type: none"> 1) The system consists of several hardware components that would be difficult to maintain. 2) Requires more expenditure.
Wael Alsafery et. al[4]	CLOUD BASED	<ol style="list-style-type: none"> 1) Reducing time. 2) Reduces the energy of the user. 3) Provides an effective approach for the cities with humongous traffic. 4) The system traces the shortest path to the vacant slots. 	<ol style="list-style-type: none"> 1) The system is quite expensive. 2) Tedious to maintain.
Praveen, M., & Harini, V.[5]	NB-IOT BASED	<ol style="list-style-type: none"> 1) Provides deeper network coverage and signals penetrating through underground. 2) NB-IoT provides a stable span of four to five years. 	<ol style="list-style-type: none"> 1) Quite expensive. 2) Requires more hardware. 3) Requires a lot of time in maintaining the system. 4) The devices on the network must be paid and the addition of telecommunication taxes increases the expenditure as well.
Bonde, et. al[6]	IOT (GSM)	<ol style="list-style-type: none"> 1) Provides a successful allotment of free parking slots to cars. 2) Tracing the proper path towards the slot. 3) LCD displaying allotment and de-allotment properly. 	<ol style="list-style-type: none"> 1) It requires a lot of time to install. 2) The system turns out to be quite expensive.
Chowdhury et. al[7]	CLOUD-OF-THINGS	<ol style="list-style-type: none"> 1) It provides all in one facility along with the payment options. 2) Provides reserved spaces for VIP's. 3) Highly Secure. 	<ol style="list-style-type: none"> 1) Requires a lot of hardware. 2) High Expenditure. 3) Requires a lot of time in installation.
Jayakshai Dadaji Bachhav et. al[8]	WI-FI TECHNOLOGY	<ol style="list-style-type: none"> 1) The system facilitates a user-friendly environment. 2) Less time for the user in finding the slots. 3) Provides more security to the user. 	<ol style="list-style-type: none"> 1) Consumes a lot of power. 2) If the sensor gets affected due to weather it will need to be replaced too.
Soundarya Rajesh et. al[9]	IMAGE PROCESSING	<ol style="list-style-type: none"> 1) The system ensures reduced mechanical and electrical liability as there is no use of sensors. 2) High level of security as the cameras would be installed for the image capture. 	<ol style="list-style-type: none"> 1) The system requires a power source ensuring the cameras and lighting for camera imaging. 2) Weather conditions might affect the visibility.
Balwant K. Patil et. al[10]	SENSOR BASED	<ol style="list-style-type: none"> 1) Reduces User's time. 2) Helps in traffic management. 3) Provides a mode of communication with the drivers for the parking. 	<ol style="list-style-type: none"> 1) The system facilitates higher performance in order to track the car but is not fully an automated system. 2) Requires a high level of maintenance.



Jiang Ruili et. al[11]	IMAGE PROCESSING & ARTIFICIAL INTELLIGENCE	1) Provide a long term area for expansion as well as solutions for problems. 2) The ANPR efficient cameras provide a good level of precision. 3) The system integrates several technologies providing every details of the vehicles to the system securely.	1) Requires a high power supply 2) High battery backup required. 3) The sensitivity elements of ultrasonic can get mechanically damaged and the risk of change in the range of ultrasonic sensors due to the weather comes out as another problem in this space.
Abhirup Khanna et. al[12]	CLOUD-OF-THINGS	1) Provides good and low cost storage capacity. 2) The system ensures the backup of the data in the cloud in order to have recovery in case of any damage to the system.	1) This system is quite complex in design. 2) Not provide much of a flexible way to park.
Bibi, N., Majid et. al[13]	MATLAB	1) Cost effective. 2) Optimize the identification of available parking slots to reduce congestion in the parking area.	1) Time Consuming 2) Includes a number of steps which makes it a bit complex.
Jaspreet Kaur et. al [14]	IMAGE PROCESSING & ARTIFICIAL INTELLIGENCE	1) Acts a multi purpose parking system helping in various activities.	1) With time the maintenance of hardware will also be required. 2) Cost of the system is more.
Vinay Raj Tripaththi [15]	IOT	1) Saves fuel consumption. 2) Saves the user's time. 3) Helps in reducing traffic congestion. 4) Controls pollution.	1) A lot of hardware will be required which will lead to more cost and will also need more maintenance.

REFERENCES RÉFÉRENCES REFERENCIAS

1. Prof. Denis Ashok (Ph.D), Akshat Tiwari, Vipul Jirge (2020), Smart Parking System using IoT Technology, 2020 International Conference on Emerging Trends in Information Technology and Engineering (ic-ETITE).
2. Jahnvi Nimble, Priyanka Bhegade, Snehal Surve, Priya Chaugule, (2016) Automatic Smart Car Parking System, International Journal Of Advances in Electronics and Computer Science, Vol-3, Mar-2016.
3. ElakyaR, Juhi Seth, Pola Ashritha, R Namith (2019), Smart Parking System using IoT, International Journal of Engineering and Advanced Technology (IJEAT), Vol-9, October 2019.
4. Wael Alsafery, Badraddin Alturki, Stephan Reiff-Marganiec & Kamal Jambi. Smart Car Parking System Solution for the Internet of Things in Smart Cities.
5. Praveen, M., & Harini, V. (2019). NB-IOT based smart car parking system. 2019 International Conference on Smart Structures and Systems (ICSSS).
6. Bonde, D. J., Shende, R. S., Kedari, A. S., Gaikwad, K. S., & Bhokre, A. U. (2014). Automated car parking system commanded by Android application. 2014 International Conference on Computer Communication and Informatics.
7. Chowdhury, L. H., Mahmud, Z. N., Z., Islam, I.-U., Jahan, I., & Islam, S. (2019). Smart Car Parking Management System. 2019 IEEE International Conference on Robotics, Automation, Artificial-Intelligence and Internet-of-Things (RAAICON).
8. Jayakshei Dadaji Bachhav1; Dept. Of Electronics and Telecommunication, SNJB's COE, Chandwad, Maharashtra, India, Prof. Mechkul M. A.2; SDept. Of Electronics and Telecommunication, SNJB's COE, Chandwad, Maharashtra, India, "Smart Car Parking System", (IRJET), Volume: 04 Issue: 06 | June-2017.
9. Soundarya Rajesh, Dr. M. G. Sumithra, "Smart Parking system using Image processing", International Research Journal of Engineering and Technology (IRJET), Vol 05, Issue 04, Apr42018.
10. Balwant K. Patil, Avinash Deshpande, Sonal Suryavanshi, Rudresh Magdum, Manjunath, "Smart Parking System for Cars", International Conference on Recent Innovations in Electrical, Electronics & Communication Engineering (ICRIEECE).
11. Jiang Ruili, Wang Haocong, Wang Han University of Electronic Science and Technology of China, Chengdu, China; Dr Eoin O'Connell Computer Science and Information Systems Department University Of Limerick; Dr Sean McGrath Electronic & Computer Engineering Department University Of Limerick, "Smart Parking System Using Image Processing and Artificial Intelligence", International Conference on Sensing Technology (ICST)-2018.
12. Abhirup Khanna; Rishi Anand, University of Petroleum and Energy Studies (UPES) Dehradun, Uttarakhand, "IoT based Smart Parking System"; 2016 International Conference on Internet of Things and Applications (IOTA) Maharashtra Institute of Technology, Pune, India 22 Jan - 24 Jan, 2016.

13. Bibi, N., Majid, M. N., Dawood, H., & Guo, P. (2017). Automatic Parking Space Detection System. 2017 2nd International Conference on Multimedia and Image Processing (ICMIP).
14. Jaspreet Kaur, (2019). Implementation of Smart Parking using Artificial Intelligence; Computer Science and Engineering, Patiala Institute of Engineering and Technology for women, Nandpur kesho. August 2019 IJSDR, Volume 4.
15. Vinay Raj Tripathi, Dept. of Electrical & Electronics, KIET Group of Institutions, Ghaziabad; 2020 International Conference on Electrical and Electronics Engineering (ICE3-2020).

