

Implementation of a Low Cost 5 Level PWM Inverter

Neelashetty Kashappa¹ and Ramesh Reddy K²

¹ University of Visvesvaraya College of Engineering (UVCE) Bangalore, India.

Received: 12 December 2012 Accepted: 4 January 2013 Published: 15 January 2013

Abstract

This paper deals with the implementation of a new low cost five level inverter which converts the 9V DC to 9V AC. Complexity and cost of the system are reduced as compared to other configurations by using only five switches, eight diodes and two capacitors. In the proposed scheme, control circuit is designed using 89C51 microcontroller to produce sinusoidal pulse width modulation (SPWM). The developed system can be operated at very high modulation frequencies of upto 200 KHz producing sustained output. This single-phase five level low cost inverter is developed and tested in power electronics laboratory. The waveforms are recorded and analyzed using Digital Storage Oscilloscope TDS2024B. The proposed scheme is very economic and less complex and the experimental results shows that it has low total harmonic distortion.

Index terms— low cost, pulse width modulation, multilevel inverter, total harmonic distortion

1 Introduction

The field of power electronics has witnessed tremendous development in recent years. The advent of new power controlled devices has contributed significantly to an enhanced performance of the existing power converters. The birth of innovative converter/inverter topologies has paved the way for further improvement in the overall power quality. Multilevel inverter has gained much attention and became more popular now a day due its high quality output waveforms, low switching losses and high voltage capability, less EMI and reduced harmonics [1]. Using multilevel inverters specific harmonics can be eliminated in order to generate less distorted sinusoidal waveform. The main features of multilevel inverters are summarized as (i) The staircase waveform of a multilevel inverter not only removes certain specific harmonics, but it also reduces the dv/dt stress. (ii) Smaller common mode (CM) voltage of multilevel inverter helps to reduce the stress in the bearing of a motor connected to multilevel inverter drive. (iii) Multilevel inverter has a capability to operate both at high switching frequency and fundamental switching frequency [1][2]. The multilevel inverters can be used medium voltage to high voltage range applications. It covers wide range areas including Uninterruptible Power Supplies (UPS), DC power source utilization, induction heating, high power motor drives, HVDC power transmission, electric vehicle drives, power distribution etc. Multilevel inverters works as voltage synthesizers. That is many smaller voltage levels synthesize high output power. The main drawback of multilevel inverter is that, as the number of levels are increased, the amount of diodes, switching devices and other required components increases causing the inverter more complex and costly [3].

A survey of topologies, control and applications of multilevel inverters is given by Rodriguez and Peng (2002). The way to balance Dc link voltages of diode clamped multilevel converters is given by Marchesoni and Tensa (2002). UPFC based chopper stabilized diode clamped multilevel converters is given by Chen Mwinyiwiwa (2000). Pulse width modulation for diode clamped multilevel converters is given by Venkatramanand ??2002). Fundamental characteristics of Fivelevel converter for induction motor drives is given by Ishida and Sasagawa (2002). Control strategies for multilevel voltage source converters is given by J Von ??2000). Diode clamped multilevel inverter for statcom is given by Chengand (2002). Simulation optimization system for multilevel inverters is given by tourkhani and Meynard (1999). Performance of medium voltage multilevel inverter is given by Hilland Harbourn (1999).

46 Comparison of 3-level and 9-level inverter-fed induction motor drives is given by Neelashetty K and Ramesh
 47 ??eddy K (2010). Performance of voltage source multilevel inverter-fed induction motor drive is given by
 48 Neelashetty K and Ramesh . Investigations on 7-level and 9-level inverter-fed induction motor drives is given by
 49 Neelashetty K and Ramesh . Literature survey does not deal with cost, complexity as well as the Total Harmonic
 50 Distortion (THD) of a multi level inverter. Therefore this work is taken up and it deals with the implementation
 51 of a low cost pulse width modulation voltage source five level inverter.

52 2 II. Implementation of Five evel Inverter a) Total harmonic 53 distortion

54 The Total Harmonic Distortion (THD) is a measure of amount of harmonic distortion present. It is defined as
 55 the ratio of sum of the power of all harmonic components to the power of fundamental frequency. In other words
 56 total harmonic distortion is the measurement of extent of that distortion.

57 3 T

58 Author ? : Assistant professor, EEE dept. GNDEC, Bidar, Karnataka, India. E-mail : neelshet-
 59 tyk@gmail.com Author ? : Professor and Dean, EEE dept GNITS, Shakepet, Hyderabad, India. E-mail :
 60 kollirameshreddy@yahoo.com Total harmonic distortion for the voltage signal can be expressed as follows:THD=
 61 $2 \frac{V_2}{V_1} + 2 \frac{V_3}{V_1} + 2 \frac{V_4}{V_1} + 2 \frac{V_5}{V_1} + \dots$ (2)

62 Where, V_n means RMS voltage of n th harmonic, V_1 is the voltage at the fundamental frequency.

63 The simplified approach for the THD is given by $THD = \sqrt{\frac{V_2^2 + V_3^2 + V_4^2 + V_5^2 + \dots}{V_1^2}}$ (3)

64 Many times amplitude ratio is taken into consideration for the measurement of total harmonic distortion and
 65 is given by $THD = \frac{V_2}{V_1} + \frac{V_3}{V_1} + \frac{V_4}{V_1} + \frac{V_5}{V_1} + \dots$ (4)

66 This latter definition is the one commonly used in audio distortion specification.

67 Choosing appropriate conducting angles for the H-bridges can eliminate a specific harmonic in the output
 68 waveform ??Rashid, 2004). The required conduction angles can be calculated by analyzing the output phase
 69 voltage of cascaded inverter assuming that four H-bridges have been used. The output voltage V_{ao} can be given
 70 as $V_{ao} = V_{a1} + V_{a2} + V_{a3} + V_{a4} + V_{a5}$ (5) Since the wave is symmetrical along the x-axis, both Fourier
 71 coefficients A_0 and A_n are zero. Just the analysis of B_n is required. It is given as; analysis of B_n is required.
 72 It is given as; ? In this case, one of the very efficiently used control strategies is the space vector based control,
 73 which can be implemented using digital signal processor. $B_n = \frac{4V_{dc}}{n} \cos(n\theta)$ (6)

74 4 b) System Overview

75 The block representation of multilevel inverter is shown in figure1. It consists of a 9V battery, five level Hbride
 76 inverter, stepdown transformer, control circuit and load. The elementary components of singe-phase multilevel
 77 inverter are MOSFETs, diodes and capacitors. A 9V DC source is given to the H-bridge multilevel inverter
 78 through two capacitors. These two capacitors functions as voltage dividers. The control circuit mainly consists
 79 of 89C51 microcontroller and optoisolator. The control circuit not only controls the system, but can also generate
 80 the pulse width modulation (PWM) signals. The most efficient method of controlling the output voltage is to
 81 incorporate the PWM signals within the inverter. These PWM signals are given to the gate of each MOSFET
 82 through the gate drive circuit. The switching of the MOSFETs is controlled by the PWM signals. This switching
 83 results the ac output voltage. This output voltage is synthesized by different small voltage levels to get a very
 84 high quality staircase output waveform. This waveform has reduced harmonic and switching losses. This high
 85 quality output voltage can be used to drive the load. The inverter has the ability to drive both resistive as well
 86 as inductive loads. Hence the proposed scheme can be used to control the induction motor. The main advantage
 87 of this proposed scheme is that, it can also be used for three phase applications. As all electronic circuits works
 88 with low DC voltage a power supply unit is required to provide the appropriate voltage supply for their proper
 89 functioning. This power supply unit consists of transformer, rectifier, filter and regulator. AC voltage of typically
 90 230V RMS is connected to a transformer which steps down the voltage to the desired AC voltage. The diode
 91 rectifier provides the full wave rectified voltage that is initially filtered by a simple capacitor filter to produce a
 92 DC voltage. This resulting DC voltage usually has some ripple or AC voltage variation. A regulator circuit can
 93 use this DC input to provide DC voltage that not only has much less ripple voltage but also remains at the same
 94 DC value, even when the input DC voltage varies somewhat or the load connected to the output DC voltage
 95 changes.

96 5 XIII Issue IX Version I

97 6 ()

98 Year Therefore, to choose the conducting angle of each H-bridge precisely, it is necessary to select the harmonics
 99 with certain amplitude and order, which needs to be eliminated. To eliminate 5th, 7th, and 11th harmonics and
 100 to provide the peak fundamental of the phase voltage equal to 80 percent of its maximum value, it needs to solve
 101 the following equation with modulation index $M=0.8$

7 III. Power and Control Circuit Design

The power circuit is designed using MOSFETs, capacitors and diodes. Single-phase H-bridge topology is used in this work. The biggest advantage of this proposed scheme is that, the components used in the design are very less compared to other topologies. This topology achieves nearly 40% reduction in the components. This reduces the complexity and cost of the system. Hence it can be efficiently used for the medium power applications. The control circuit is designed using ATMEL 89C51 microcontroller. The microcontroller is programmed using C language. A Keil C is used as integrated development environment for developing the required embedded system. The control circuit is mainly responsible for generating the pulse width modulation (PWM) signals given to gate of each MOSFET through separate optoisolator and gate drive circuit. These PWM signals controls the turning on and off of the MOSFETs. A dead time of 2 microseconds is given between turning on and off of MOSFETs and vice versa. In this proposed scheme a duty cycle of 50% is used.

8 IV.

9 Experimental Results

A new low cost H-bridge multilevel inverter is developed and tested in power electronics laboratory.

10 Conclusion

A laboratory prototype of H-bridge five level inverter is developed. The proposed topology has successfully converted 9V DC to 9V AC with reduced cost, less complexity and low THD. The experimental results of 5-level inverter system are compared with the 3-level inverter system. It is observed that the total harmonic distortion produced by 5-level inverter system is less than that of a 3-level voltage source inverter system. The THD is reduced by 5 percent. Therefore the heating due to 5-level inverter system is less than the 3level inverter system. The proposed system is economic, efficient and reliable and can be used for medium as well as high power applications. The experimental waveforms and the FFT spectrums are presented. The hardware module is implemented using embedded controller.

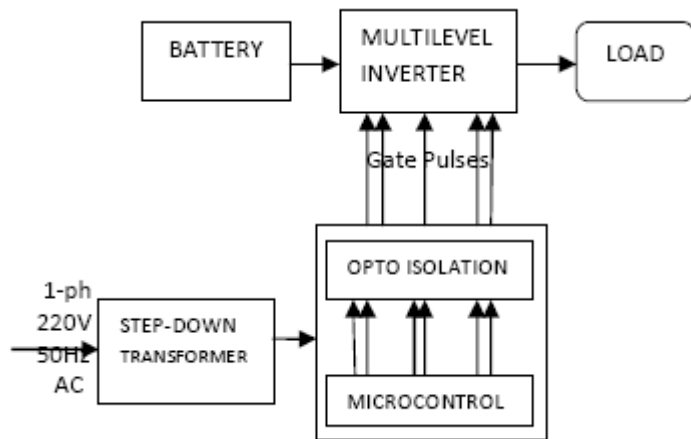

Figure 1: F

124

¹© 2013 Global Journals Inc. (US)

²© 2013 Global Journals Inc. (US) © 201



1

Figure 2: Cos? 1 +

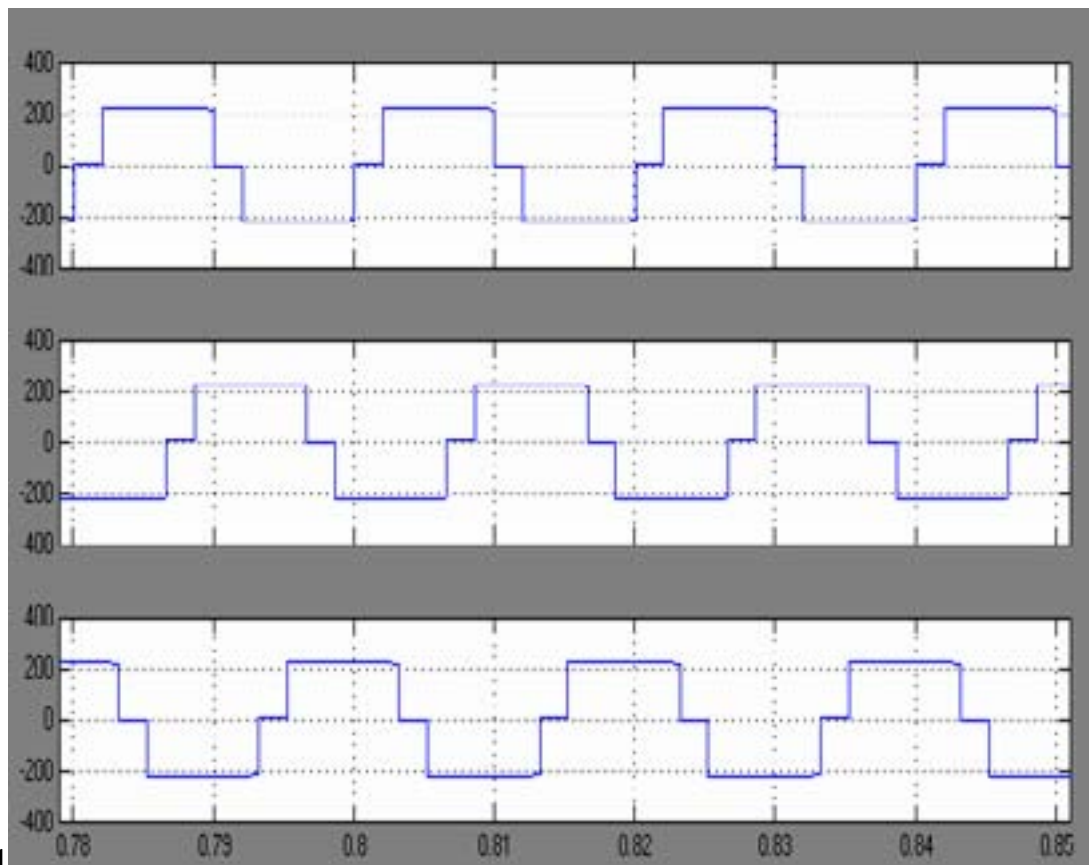

1

Figure 3: Figure 1 :

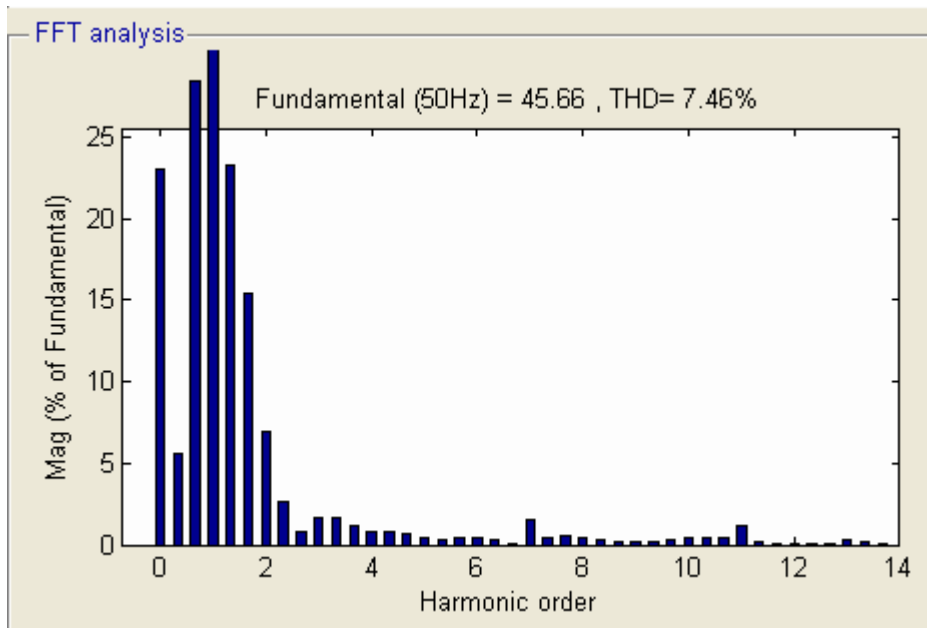

Figure 4:

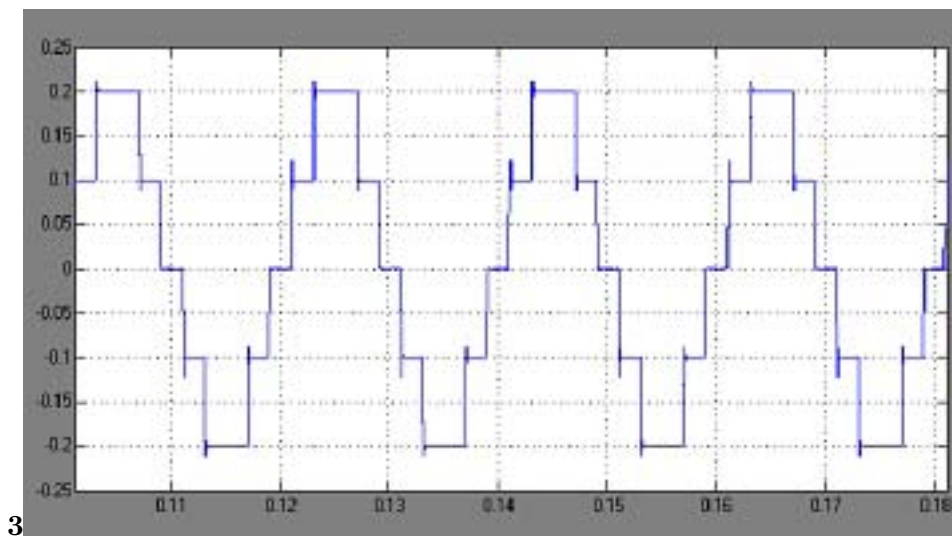

Figure 5: Figure 3 a

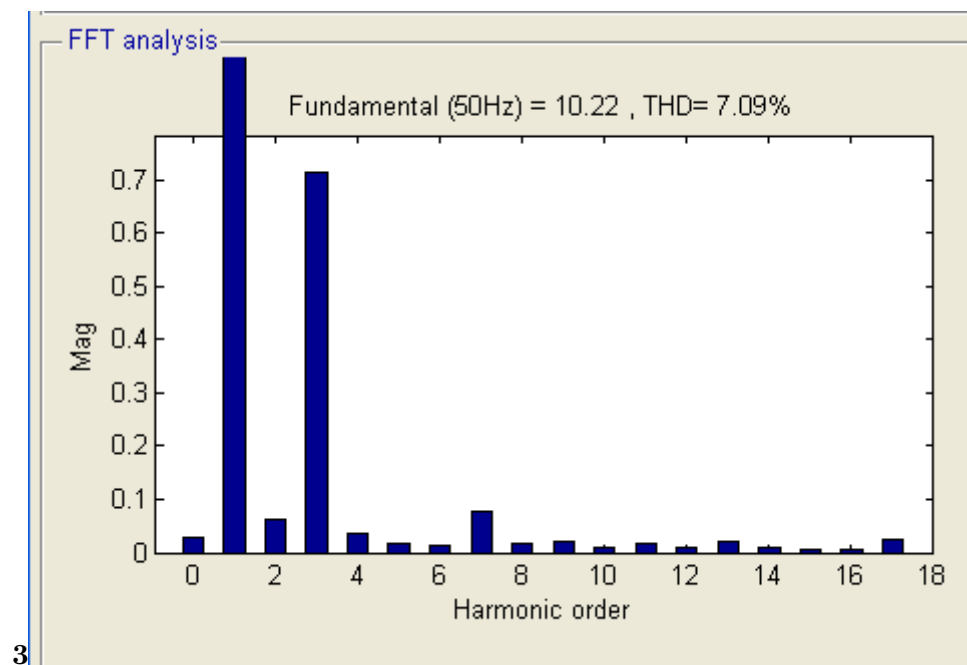

Figure 6: Figure 3 b



4

Figure 7: Figure 4 :

-
- 125 [Chengand and Crow (2002)] ‘A Diode-Clamped Multi-Level Inverter for the Statcom/BESS’. Y Chengand , M
126 L Crow . *Proc. IEEE PES Winter Meeting*, (IEEE PES Winter Meeting) Jan 2002. 1 p. .
- 127 [Tourkhani et al. (1999)] ‘A simulation optimization system for the optical design of a multilevel inverter’. F
128 Tourkhani , P Viarouge , T A Meynard . *IEEE Transactions on Power Electronics* Nov.1999. 14 (6) p. .
- 129 [Reddy ()] ‘Comparison of 3-level and 9-level Inverter-fed Induction motor Drives’. Neelashetty , Ramesh Reddy
130 , K . *Research Journal of Applied Sciences, Engineering and Technology* 2011. 3 (2) p. .
- 131 [Blohand and Dedoncker (2000)] ‘Control Strategies for Multilevel Voltage Source Converter for Medium Voltage
132 DC Transmission Systems’. J Blohand , R W Dedoncker . *Proceedings of 26th Annual Conf. IEEE Industrial
133 Electronics*, (26th Annual Conf. IEEE Industrial Electronics) Oct 2000. 2 p. .
- 134 [Marchesoni and Tensa (2002)] ‘Diode-clamped multi level converters: a practicable way to balance DClink
135 voltages’. M Marchesoni , P Tensa . *IEEE Transactions on Industrial Electronics* Aug 2002. 49 (4) p. .
- 136 [Ishida et al. (2002)] ‘Fundamental Characteristics of a Five-Level Double Converter for Induction Motor Drives’.
137 T Ishida , K Matsuse , K Sasagawa , L Huang . *IEEE transac on industrial electronics* Aug 2002. 49 (4) p. .
- 138 [Reddy ()] ‘Investigations on 7-level and 9-level Inverter-fed Induction Motor Drives’. Neelashetty , Ramesh
139 Reddy . *International Journal of Computational Intelligence and Information Society* 2011. 2 (11) .
- 140 [Rodriguez et al. (2002)] ‘Multi-level inverter: a survey of topologies, controls, and applications’. J Rodriguez ,
141 J S Lai , F Z Peng . *IEEE Trans. on Ind. Electronics* Aug 2002. 49 (4) p. .
- 142 [Hilland and Harbourt] ‘Performance of medium voltage multi level inverters’. W A Hilland , C D Harbourt .
143 *Conf Rec. IEEE-Oct1999*, p. .
- 144 [Reddy K ()] ‘Performance of Voltage Source Multilevel Inverter-fed Induction Motor Drives’. Neelashetty ,
145 Ramesh Reddy K . *International Journal of Asian Research Publishing Network* 2011. 6 (6) p. .
- 146 [Singh] *Power electronic devices and application*, M D Singh , Kanchandani .
- 147 [Rashid] *Power Electronics -Circuits*, M H Rashid . Device and Applications.
- 148 [Venkataramananand and Bendre (2002)] ‘Reciprocitytranspositions based sinusoidal pulse width modulation
149 for diode clamped multi level converters’. G Venkataramananand , A Bendre . *IEEE Trans. on Ind. Electronics*
150 Oct 2002. 49 (5) p. .
- 151 [References Références Referencias Implementation of a Low Cost 5 Level Pwm Inverter] *References Références*
152 *Referencias Implementation of a Low Cost 5 Level Pwm Inverter*,
- 153 [Chen et al. (2000)] ‘Unified Power Flow Controller (UPFC) based on chopper stabilized diode clamped multi
154 level converters’. Y Chen , B Mwinyiwiwa , Z Wolanski , B.-T Ooi . *IEEE Trans. on Power Electronics*
155 Mar.2000. 15 (2) p. .